

**FANUC AC SPINDLE MOTOR S series**

**OPERATOR'S MANUAL**

**B-65014E/02**

- No part of this manual may be reproduced in any form.
- The appearance and specifications of this product are subject to change without notice.

The products in this manual are controlled based on Japan's "Foreign Exchange and Foreign Trade Law". The export from Japan may be subject to an export license by the government of Japan.

Further, re-export to another country may be subject to the license of the government of the country from where the product is re-exported. Furthermore, the product may also be controlled by re-export regulations of the United States government.

Should you wish to export or re-export these products, please contact FANUC for advice.

In this manual, we endeavor to include all pertinent matters.

There are, however, a very large number of operations that must not or cannot be performed, and if the manual contained them all, it would be enormous in volume.

It is, therefore, requested to assume that any operations that are not explicitly described as being possible are "not possible".

## CONTENTS

I. FANUC AC SPINDLE MOTOR .....	1
1. GENERAL .....	3
2. INSTALLATION AND STORAGE .....	3
2.1 Installation Location .....	3
2.2 Connection .....	3
2.3 Storage .....	3
2.4 Power Supply .....	3
2.4.1 Installing an earth leakage circuit breaker .....	3
2.4.2 Power capacitors .....	4
2.5 Allowable Radial Load .....	4
3. TEST RUN .....	4
3.1 Check Items before Starting Operation .....	4
3.2 Check Items after Starting Operation .....	4
3.3 Check after Stored for a Long Period .....	4
4. MAINTENANCE .....	5
4.1 Periodical Maintenance Items .....	5
4.2 Checking the Bearing .....	5
4.3 Cleaning the Fan Motor .....	5
5. TROUBLESHOOTING (TROUBLE CHECK LIST) .....	6
II. FANUC AC SPINDLE SERVO UNIT .....	7
1. GENERAL .....	9
2. INSTALLATION AND STORAGE .....	9
2.1 AC Spindle Servo Unit Installation .....	9
2.2 Installation of the Machine/System Containing the AC Spindle Servo Unit .....	9
2.3 Connection .....	9
2.3.1 Check of power supply voltage .....	9
2.3.2 Connection of protective earth .....	9
2.3.3 Connection of power supply .....	9
2.4 Storage .....	10
2.5 Power Supply .....	10
3. TEST RUN .....	10
3.1 Check before Starting Operation .....	10
3.2 Precautions to take when Turning on the Power .....	10
4. MAINTENANCE .....	10
5. TROUBLESHOOTING .....	11
5.1 Alarm Display .....	11
5.1.1 AL- is displayed (PCB drawing No. A16B-1100-0200) .....	11
5.1.2 When AL- is displayed (PCB drawing No. A20B-1003-0010) .....	12
5.2 When Power ON Lamp PIL (Green) Is Not Lit .....	14
6. PRECAUTIONS TO TABLE ON REPLACEMENT OF FUSE .....	15
7. SPARE PARTS .....	15
7.1 AC Spindle Servo Unit S Series (fuse specifications A06B-6059-KXXX) .....	15
8. MOUNTING DRAWING .....	16
8.1 PCB Parts Layout Diagram .....	16
8.1.1 Model 1S-3S A16B-1100-0200 .....	16
8.1.2 Model 6S-22S A20B-1003-0010 .....	17
8.2 Unit Parts Layout Diagram (Fuse only) .....	18
8.2.1 AC spindle servo unit model 6S-12S (A06B-6059-H206, -H208, -H212) .....	18
8.2.2 AC spindle servo unit model 15S-22S (A06B-6059-H215, -H218, -H222) .....	18



## I. FANUC AC SPINDLE MOTOR

DO  
, EC



## 1. GENERAL

This chapter describes the operating procedure on FANUC AC SPINDLE MOTOR S-series used for NC machine tool.

To prolong the life of the spindle motor and to prevent an unexpected accident, make a practical maintenance plan according to the operating environments and conditions by referring to this chapter, and carry out the maintenance and inspection.

## 2. INSTALLATION AND STORAGE

### 2.1 Installation Location

Install the AC spindle motor in places meeting the following conditions.

- 1) The installing surface is flat and rigid, and considered to minimize the influence of machine's vibration.
- 2) Sufficient air can be supplied to the cooling fan motor. Accessible to the cooling unit for inspection and maintenance.
- 3) Minimum dust and low humidity.
- 4) Places not exposed to the splash of the cutting fluid and oil.
- 5) The ambient temperature is 0 ~ 40°C.

### 2.2 Connection

For the details of the connection between the AC spindle motor and the AC spindle servo unit, refer to the general connection diagram attached to each machine.

Note) A three-phase fan motor is used for cooling the AC spindle motor S-series. Make the connection according to the order of phases indicated at the terminal.

### 2.3 Storage

Don't leave the motor outdoor. Store it indoor free from extreme change in temperature and high humidity.

### 2.4 Power Supply

#### 2.4.1 Installing an earth leakage circuit breaker

Be sure to use an earth leakage circuit breaker or a leak alarm in the power supply of factory or the machine for prevention of fire and operator's safety. As the AC spindle servo unit employs the transistor pulse width modulation control system, a high frequency leakage current flows through the stray capacity of cable and motor, but the 50/60Hz component is less than the non-operating current (15mA) of ordinary high-sensitivity high-speed earth leakage circuit breaker.

In some types of earth leakage circuit breaker and alarm, a mal-function by high frequency current is likely to occur or some are operated by the rush current (impulsive wave) when the power is turned on. Select the earth leakage circuit breaker or alarm unit the following performance, by consulting with the manufacturer.

- 1) Not sensitive to a high frequency component for avoiding an unnecessary operation for a high frequency leakage current without spoiling the protective characteristic.
- 2) Not operated by a impulsive wave.

#### 2.4.2 Power capacitors

The power-efficiency of input power supply during the AC spindle motor drive is 0.9 or higher. Don't install a power capacitors in the input power supply of the AC spindle servo unit.

### 2.5 Allowable Radial Load

Set the radial load of the motor output shaft to the radial load specified in the table below.

Motor	1S	1.5S	2S	3S	6S	8S	12S/15S	18S/22S
Allowable radial load	40kg	90kg	90kg	150kg	200kg	300kg	300kg	450kg

Note) The radial loads are the values obtained when the point of application is taken at the output axis end.

### 3. TEST RUN

Check the following points when the motor is initially operated after the installation or after the change of installation place.

#### 3.1 Check Items before Starting Operation

- 1) Connection is made correctly.
- 2) The joints are completely tightened or insulated.
- 3) The motor fixing screws are firmly tightened.
- 4) The motor is grounded.

#### 3.2 Check Items after Starting Operation

- 1) The speed command value coincides with the motor speed.
- 2) The load meter (output meter) indicates reasonable value.
- 3) The motor operates without abnormal noise or vibration.
- 4) The bearing temperature or the exhaust temperature is not suddenly increased.

#### 3.3 Check after Stored for a Long Period

Make trial running when operating the motor after it has been stored for a long period (over several months).

## 4. MAINTENANCE

### 4.1 Periodical Maintenance Items

The periodical maintenance items are as shown below.

Inspection period	Inspection item
Routine maintenance and inspection (daily) (Verify during operation)	① Rotation speed ② Abnormal vibration ③ Abnormal noise ④ Ventilation (Rotation of fan motor) ⑤ Bearing temperature ⑥ Case temperature ⑦ Abnormal smell
Maintenance and inspection at every 6 months (1 year at least)	① Bearing check ② Fan motor cleaning ③ Ventilation port cleaning ④ Insulation resistance measurement

The inspection interval is for the usual operation.  
Set an appropriate interval according to the operating conditions.

### 4.2 Checking the Bearing

For FANUC AC Spindle motors, a grease sealed bearing is used and it is unnecessary to replenish grease. Check the following points periodically. The standard interval is 6 months.

- 1) Temperature increase in the bearing  
The maximum allowable temperature is 80°C. The allowable temperature increase at a room temperature of 40°C is 40°C.
- 2) Noise and vibration  
A defect in the bearing is detected by an abnormal noise or vibration. Pay attention to these points during operation.

### 4.3 Cleaning the Fan Motor

If the finger guard or ventilation port of the fan motor is dusty, the cooling performance of the fan motor is lowered spoiling the ratings and causing a defect by heating. The recommended inspection period is 6 months.  
If the finger guard or the ventilation port is clogged with dust, clean it immediately.

## 5. TROUBLESHOOTING (TROUBLE CHECK LIST)

Item	Symptom	Possible cause	Remedy
1	Abnormal vibration	(1) Influence by mounting and load (2) Defective speed detector (3) Defective AC spindle servo unit	(1) Check the load condition. (2) Contact with FANUC service. (3) Contact with FANUC service.
2	Motor temperature is abnormally high.	(1) Defective cooling  (2) Abnormally loaded	(1) Check and clean the fan motor. (Contact with FANUC service.) (2) Check the load condition (Contact with FANUC service.)
3	Abnormal noise	(1) Defective speed detector (2) Defective bearing (3) Motor trouble (4) Irregular mounting or load	(1) Contact with FANUC service. (2) Contact with FANUC service. (3) Contact with FANUC service. (4) Check the load condition.
4	Output power is low	(1) Lowered input supply voltage  (2) Motor trouble	(1) Check the power supply voltage. Check the transformer setting. (Contact with FANUC service.) (2) Check the motor temperature. (Contact with FANUC service.)
5	Acceleration/ deceleration time is too long. Orientation fails. Rotation speed is different from the command. Rotation fails. Others	(1) Defective AC spindle servo unit	(1) Contact with FANUC service.
6	Earth leakage circuit breaker operates.	(1) Defective motor insulation. (2) Malfunction of circuit breaker	(1) Contact with FANUC service. (2) Replace the circuit breaker.

## II. FANUC AC SPINDLE SERVO UNIT

DOC  
, EC



## 1. GENERAL

This chapter describes the handling of the FANUC AC SPINDLE SERVO UNIT S series that controls the FANUC AC SPINDLE MOTOR S series used for driving the spindle of NC machine tool.

Handle the unit correctly according to the operating environment and conditions by referring to this chapter.

## 2. INSTALLATION AND STORAGE

### 2.1 AC Spindle Servo Unit Installation

The primary installation conditions are as follows.

Ambient temperature: 0 ~ 55°C  
Relative humidity : 95% max. (no dewing)  
Vibration : 0.5G max.

### 2.2 Installation of the Machine/System Containing the AC Spindle Servo Unit

- 1) Take sufficient space for maintenance in front of the cabinet door of the machine/system.
- 2) Don't block the air flow of the cooling unit.

### 2.3 Connection

#### 2.3.1 Check of power supply voltage

Before connecting the power supply, check the input power supply voltage and when the power supply voltage is over 254 V AC, use an insulation transformer and set the input voltage to 200 V AC.

#### 2.3.2 Connection of protective earth

Before connecting the power supply, ground the connection terminal "G".

#### 2.3.3 Connection of power supply

Connect the power lines to the unit after grounding the terminal "G".  
Phase rotation of the power supply is not specified for the AC spindle servo unit.

## 2.4 Storage

When the NC machine tool is not used immediately after installing the AC spindle servo unit or motor, cover it with a vinyl sheet for dust protection and store it in a dry place.

## 2.5 Power Supply

For the precautions on the power supply, refer to "I. FANUC AC SPINDLE MOTOR, item 2.4 Power supply".

## 3. TEST RUN

Check the following items when operating the machine initially after the installation or re-installation.

### 3.1 Check before Starting Operation

- 1) The signal line connector and power lines are correctly and tightly connected.
- 2) The magnetics cabinet is securely grounded.

### 3.2 Precautions to take when Turning on the Power

- 1) The door of the magnetics cabinet containing the AC spindle servo unit must be closed during operation.
- 2) When the door of the magnetics cabinet needs to be opened, a personnel who is trained to maintenance the system must open after turning off the input breaker and the power source switch to the magnetics cabinet.
- 3) A high voltage is applied to the PCB or the cable during operation. Take sufficient care not to touch the tool or hand when it is inevitable to open the cabinet door during operation. Also in this case, the person trained in the maintenance of the machinery must do so.

## 4. MAINTENANCE

- 1) When a filter is used in the magnetics cabinet, clean it once a month.
- 2) The AC spindle servo unit has a heat sink which needs forced air-cooling. The cooling fan for the heat sink is to be cleaned every 6 months to keep a rated performance.

## 5. TROUBLESHOOTING

The trouble details are indicated by the 7 segment light-emitting diode indicator on the PCB in the AC spindle servo unit. About the 7 segment LED mounting position, refer to "8. Mounting Diagram" for the indicator of this chapter.

### 5.1 Alarm Display

The alarm display of AC spindle servo unit S series shows the alarm No (AL-□□). Typical alarms and countermeasures are shown below.

#### 5.1.1 AL-□□ is displayed (PCB drawing No. A16B-1100-0200)

Display	Meaning of display	Countermeasure
AL-01	Motor overheat detection operates. Heat sink overheat detection operates	(1) Check the cutting condition and the tool for wear. (2) Check the fan motor to cool the motor. (3) Check the fan motor to cool the heat sink.
AL-02	Excessive velocity deviation detection operates	(1) Check the cutting condition and tool for wear.
AL-03	Malfunction of regenerative circuit	(1) Check the resistance value of the regenerative discharge resistance.
AL-08	Overvoltage detection operates	(1) Check the input power supply voltage.
AL-10	Low voltage detection operates	(1) Check the input power supply voltage (low voltage).
AL-11	Overvoltage of DC link	(1) Check the input power supply voltage. (2) Check the DC link voltage

When any alarm other than the one specified above occurs, contact FANUC. In such cases, verify the operating status before occurrence of the defect and the 7 segment LED display status on the PCB. The actual mounting position of the alarm display varies with the PCB, refer to Chapter 8. Mounting Drawing.

5.1.2 When AL-□□ is displayed (PCB drawing No. A20B-1003-0010)

(1) P.C.B is 09A version and before.

Display	Meaning of display	Countermeasure
AL-01	Motor overheat detection operates	(1) Check the cutting condition and the tool for wear. (2) Check the fan motor for cooling the motor.
AL-02	Excessive velocity deviation	(1) Check the cutting condition and the tool for wear.
AL-03	+24 V fuse is blown	(1) Check the +24 V fuse for conductivity, and replace it if necessary.
AL-04	Lack of input power supply	(1) Check the input power supply voltage.
AL-08	Overvoltage detection operates	(1) Check the input power supply voltage.
AL-09	Heat sink overheat detection operates	(1) Check the cutting condition to see whether the operation is overloaded. (2) Check the heat sink cooling fan motor.
AL-10	Low voltage detection of power supply voltage operates	(1) Check the input power supply voltage (low voltage).
AL-11	Overvoltage of DC link	(1) Check the input power supply voltage. (2) Check the DC link voltage.

(2) P.C.B is 10B version and after

Display	Meaning of display	Countermeasure
AL-01	Motor overheat Detection operates	(1) Check the cutting condition and the tool for wear. (2) Check the fan motor for cooling the motor.
AL-02	Excessive velocity deviation	(1) Check the cutting condition and the tool for wear.
AL-04	Lack of input power supply	(1) Check the input power supply voltage.
AL-08	Overvoltage detection operates	(1) Check the input power supply voltage.
AL-09	Heat sink overheat detection operates	(1) Check the cutting condition to see whether the operation is overloaded. (2) Check the heat sink cooling fan motor.
AL-10	Low voltage detection of power supply voltage operates	(1) Check the input power supply voltage (low voltage).
AL-11	Overvoltage of DC link	(1) Check the input power supply voltage. (2) Check the DC link voltage.

When any alarm other than the one specified above occurs, contact with FANUC. In such cases, verify the operating status before occurrence of the defect and the 7 segment LED display status on the PCB.

## 5.2 When Power ON Lamp PIL (Green) Is Not Lit

Item	Cause of defect	Check method	Countermeasure
1	AC power is not supplied.	Check the power voltage at the power input terminals R, S and T.	
2	The fuses F1, F2 are blown out. (Models 1S-3S)	Check F1 and F2.	Replace the fuses F1 (1.0A) and F2(3.2A).
	The fuses F2, F3 are blown out. (Models 6S-22S) (P.C.B is 09A version and before.)	Check the fuse F2 by its alarm induction. Check the fuse F3.	Replace the fuses F2 (3.2A) and F3(1.0A).
	The fuses F2, F3 are blown out. (Models 6S-22S) (P.C.B is 10B version and after.)	Check the fuse F3.	Replace the fuses F3 (1.0A).
3	Fuses FUR, FUS and FUT are blown out.	Check FUR, FUS and FUT,	Replace fuses FUR, FUS and FUT (5A).

For the lamp mounting position, refer to "8. Mounting diagram" of this chapter.

## 6. PRECAUTIONS TO TABLE ON REPLACEMENT OF FUSE

If the fuse is blown immediately after being replaced, the other cause must be expected.

Verify the alarm No. and the operating status before the fuse blowing, and contact with FANUC service.

Before replacing the fuse, please read the following precautions. For the fuse mounting position, refer to "8. Mounting diagram" of this chapter.

- 1) Before touching to the fuse, turn off the main switch of the magnetics cabinet and the switch of the power source to the cabinet check the power input at the fuse not to be alive.
- 2) When loosening the screws, take care not to lose the washers.
- 3) After replacing the fuse, mount the fuse cover.
- 4) Be sure to close the door of the magnetics cabinet when turning on the main switch of the magnetics cabinet and the switch on the side of the plant supplying power to the magnetics cabinet.

## 7. SPARE PARTS

Keep spare parts (fuses) for AC spindle servo unit under in use.

### 7.1 AC Spindle Servo Unit S series (fuse specifications A06B-6059-KXXX)

Fuse	Specification Drawing No.	1S - 3S	6S - 12S	15S - 22S
		K003	K012	K022
Fuse (0.3A)	A60L-0001-0175/03.A	3	3	3
Fuse (1.0A)	A60L-0001-0175/1.0A	2	2	2
Fuse (3.2A)	A60L-0001-0175/3.2A	1		
Fuse (5.0A)	A60L-0001-0031/5A		3	3
Alarm fuse (1.0A)	A60L-0001-0046/1.0		1	1
Alarm fuse (3.2A)	A60L-0001-0046/3.2		1	1
Surge absorber	A50L-2001-0155/20D431		1	1

## 8. MOUNTING DRAWING

### 8.1 PCB Parts Layout Diagram

#### 8.1.1 Model 1S ~ 3S A16B-1100-0200

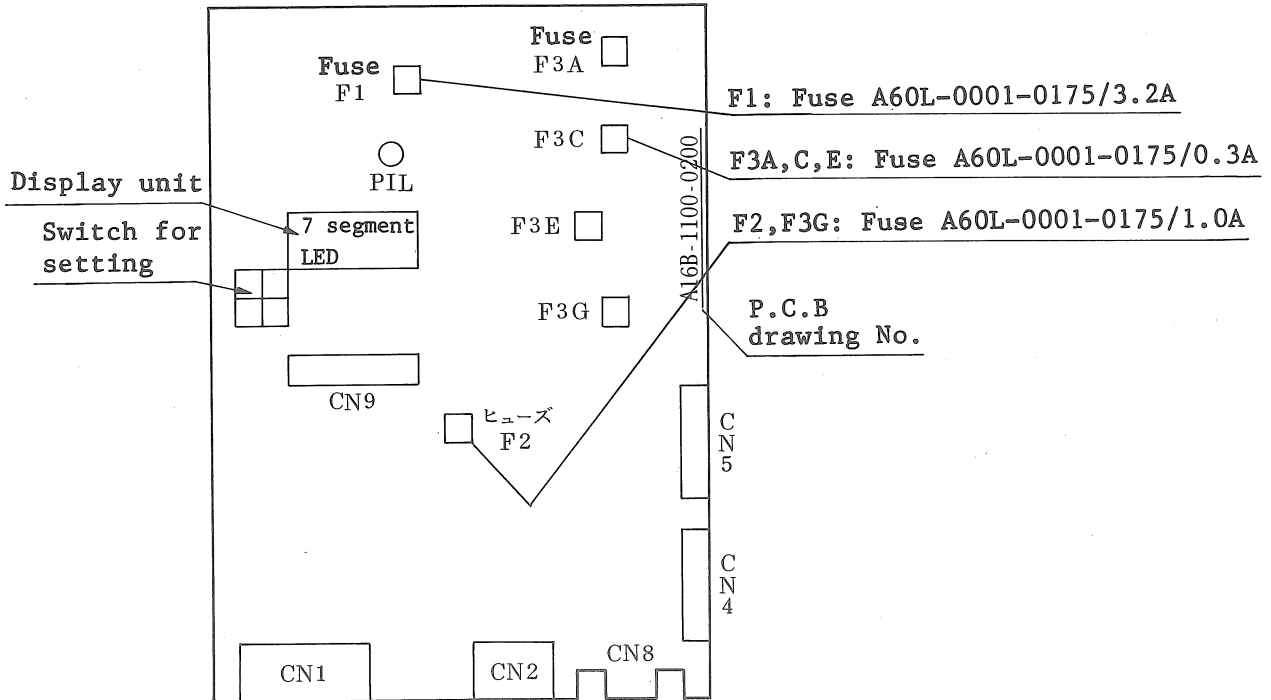

Fig. 8.1(a)

8.1.2 Model 6S ~ 22S A20B-1003-0010

(1) P.C.B is 09A version and before.

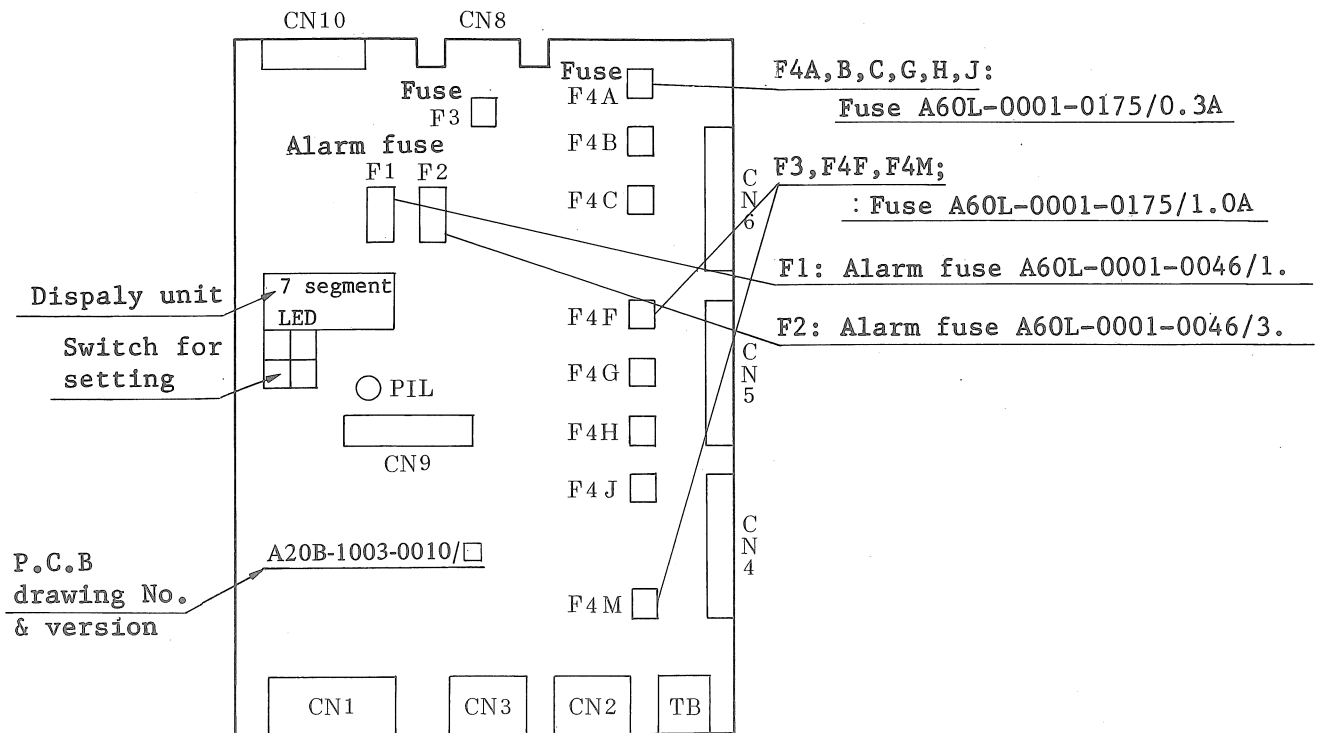
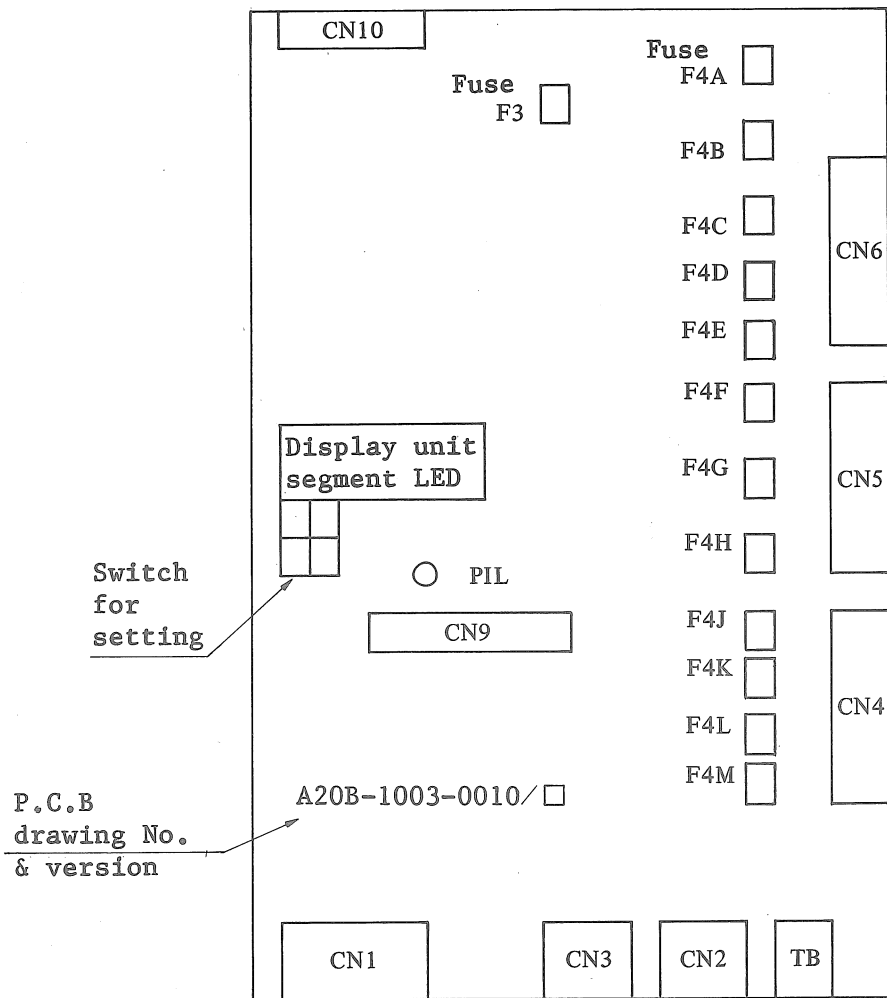

Fig. 8.1(b)

(2) P.C.B is 10B version and after.



F4A,B,C,D,E,F,G,H,J,K,L,M: fuse A60L-0001-0175/0.3A

F3: fuse A60L-0001-0175/1.0A

## 8.2 Unit Parts Layout Diagram (Fuse only)

### 8.2.1 AC spindle servo unit model 6S-12S (A06B-6059-H206, -H208, -H212)

The fuses for FUR, FUS and FUT of the AC Spindle Servo Unit Model 6S ~ 12S are mounted on PCB A20B-1003-0020.

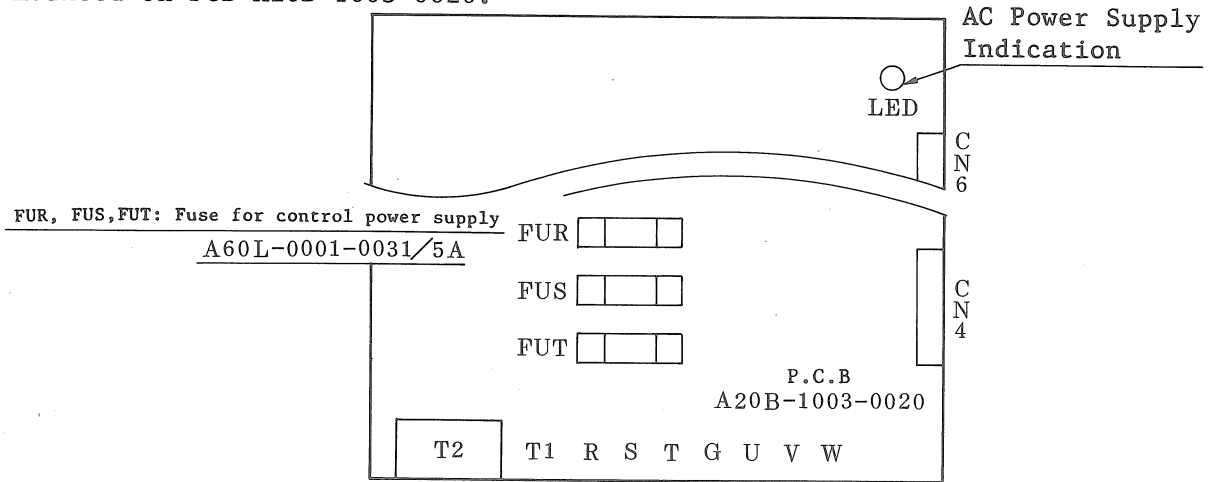

Fig. 8.2(a)

### 8.2.2 AC spindle servo unit model 15S-22S (A06B-6059-H215, -H218, -H222)

The fuses FUR, FUS and FUT of the AC Spindle Servo Unit Model 15S ~ 22S are mounted on PCB A20B-1003-0120.

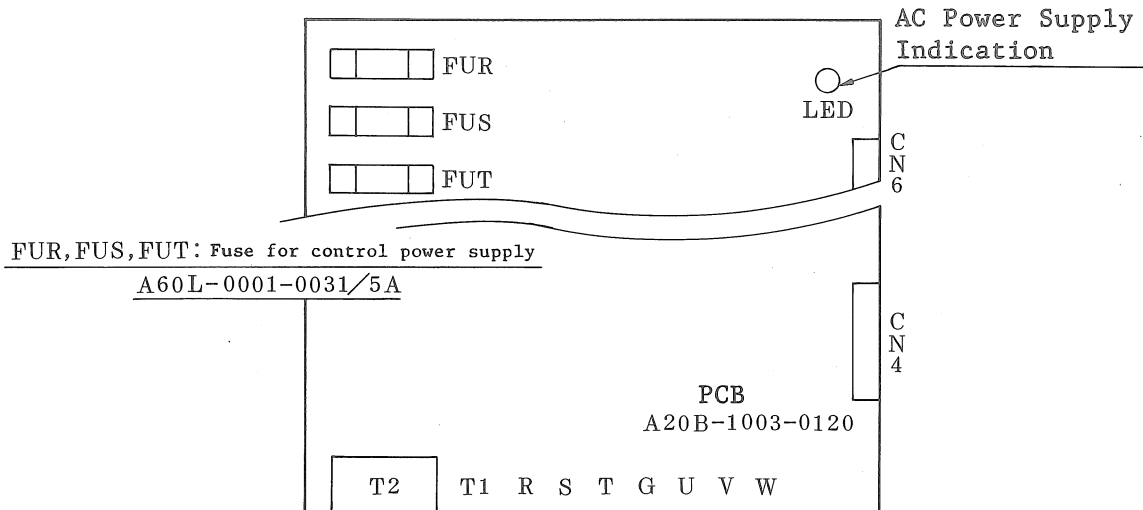

Fig. 8.2(b)



Revision Record

AC SPINDLE MOTOR S series OPERATOR'S MANUAL (B-65014E)

Edition	Date	Contents	Edition	Date	Contents	
02	'90. 8	Deleting fuses F1, F2 Modification constitution fuse F4				
01	'88. 7	_____				

'DO 'EC

JR AUTOMATION TEC  
JDC

**B-65014E/02**



\* B - 6 5 0 1 4 E / 0 2 \*