

FANUC AC SERVO MOTOR βi series

FANUC AC SPINDLE MOTOR βi series

FANUC SERVO AMPLIFIER βi series

MAINTENANCE MANUAL

JR AUTOMATION TECHNOLOGIES
JDOWLING

B-65325EN/02

- No part of this manual may be reproduced in any form.
- All specifications and designs are subject to change without notice.

The products in this manual are controlled based on Japan's "Foreign Exchange and Foreign Trade Law". The export from Japan may be subject to an export license by the government of Japan.

Further, re-export to another country may be subject to the license of the government of the country from where the product is re-exported. Furthermore, the product may also be controlled by re-export regulations of the United States government.

Should you wish to export or re-export these products, please contact FANUC for advice.

In this manual we have tried as much as possible to describe all the various matters.

However, we cannot describe all the matters which must not be done, or which cannot be done, because there are so many possibilities.

Therefore, matters which are not especially described as possible in this manual should be regarded as "impossible".

- If operation is abnormal, for example, when an alarm is issued or a hardware failure occurs, the operation described in this manual is not guaranteed unless otherwise specifically noted. If operation is abnormal, take action according to the instructions specifically described in this manual if any or contact FANUC when the instructions are not described.

- Generally, a "safety function" means a function that protects the operators from danger posed by the machine.

The signals and functions described in this manual cannot be used separately for any "safety function" unless otherwise described as being [usable for the safety function]. Their specifications are not assumed to be used as the [safety function] in this case, unexpected danger may be caused. If you have any questions, contact FANUC.

- A device connection error or setting error can lead to unpredictable operation. When starting to operate the machine for the first time after assembling the machine, replacing parts, or changing parameter settings, exercise extreme care.

SAFETY PRECAUTIONS

The "Safety Precautions" section describes the safety precautions relating to the use of FANUC servo motors, spindle motors, and servo amplifiers (βi SV βi SVSP). Users of any servo motor or amplifier model are requested to read the "Safety Precautions" carefully before using the servo motor or amplifier. The users are also requested to read an applicable specification manual carefully and understand each function of the motor or amplifier for correct use. The users are basically forbidden to do any behavior or action not mentioned in the "Safety Precautions." They are invited to ask FANUC previously about what behavior or action is prohibited.

Contents

DEFINITION OF WARNING, CAUTION, AND NOTE.....	s-2
FANUC AC SERVO MOTOR βi series, FANUC AC SPINDLE MOTOR βi series.....	s-3
Warning.....	s-3
Caution.....	s-5
Note.....	s-6
FANUC SERVO AMPLIFIER βi series.....	s-8
Warnings and Cautions Relating to Mounting.....	s-8
Warning.....	s-8
Caution.....	s-9
Note.....	s-10
Warnings and Cautions Relating to a Pilot Run.....	s-10
Warning.....	s-10
Caution.....	s-11
Warnings and Cautions Relating to Maintenance.....	s-12
Warning.....	s-12
Caution.....	s-13
Note.....	s-13

DEFINITION OF WARNING, CAUTION, AND NOTE

This manual includes safety precautions for protecting the user and preventing damage to the machine. Precautions are classified into Warning and Caution according to their bearing on safety. Also, supplementary information is described as a Note. Read the Warning, Caution, and Note thoroughly before attempting to use the machine.

WARNING

Applied when there is a danger of the user being injured or when there is a damage of both the user being injured and the equipment being damaged if the approved procedure is not observed.

CAUTION

Applied when there is a danger of the equipment being damaged, if the approved procedure is not observed.

NOTE

The Note is used to indicate supplementary information other than Warning and Caution.

If a precaution described even as "CAUTION" is not followed, a serious result may be caused depending on the status. Be sure to follow the precautions described as "WARNING" and "CAUTION" since they give important information.

* Read this manual carefully, and store it in a safe place.

FANUC AC SERVO MOTOR β i series, FANUC AC SPINDLE MOTOR β i series

Warning

WARNING

- **Be sure to ground a motor frame.**

To avoid electric shocks, be sure to connect the grounding terminal in the terminal box to the grounding terminal of the machine.

- **Before starting to connect a motor to electric wires, make sure they are isolated from an electric power source.**

A failure to observe this caution is vary dangerous because you may get electric shocks.

- **Do not ground a motor power wire terminal or short-circuit it to another power wire terminal.**

A failure to observe this caution may cause electric shocks or a burned wiring.

- **When connecting a cord such as a power line to the terminal block, use specified tightening torque to firmly connect the cord.**

If operation is performed with a loose terminal, the terminal block can overheat, resulting in a fire. Moreover, a terminal can be detached, resulting in a ground fault, short circuit, or electric shock.

- **Do not apply current when a terminal of the terminal block or the crimp terminal of a power line is exposed.**

If the hand or a conductive object touches a terminal of the terminal block or the crimp terminal of a power line, you may get electric shocks. Attach an insulation cover (accessory) onto the terminal block. Moreover, cover the crimp terminal at the tip of a power line with an insulation tube.

- **Assemble and install a power connector securely.**

If a power line is detached due to a failure in crimping or soldering, or a conductive area is exposed due to a failure in shell assembly, you may get electric shocks.

- **Do not touch a motor with a wet hand.**

A failure to observe this caution is vary dangerous because you may get electric shocks.

- **Before touching a motor, shut off the power to it.**

Even if a motor is not rotating, there may be a voltage across the terminals of the motor.

Especially before touching a power supply connection, take sufficient precautions.

Otherwise you may get electric shocks.

- **Do not touch any terminal of a motor for a while (at least 20 minutes) after the power to the motor is shut off.**

High voltage remains across power line terminals of a motor for a while after the power to the motor is shut off. So, do not touch any terminal or connect it to any other equipment. Otherwise, you may get electric shocks or the motor and/or equipment may get damaged.

- **On the machine, install a stop device for securing safety.**

The brake built into the servo motor is not a stop device for securing safety. The machine may not be held if a failure occurs.

⚠ WARNING

- **Do not enter the area under the vertical axis without securing safety.**
If a vertical axis drop occurs unexpectedly, you may be injured.
- **Fasten a motor firmly before driving the motor.**
If a motor is driven when the motor is not fastened firmly or is fastened insufficiently, the motor can tumble or is removed, resulting in a danger. If the motor mounting section is not sufficiently strong, the machine may be damaged or the user may be injured.
- **Do not get close to a rotary section of a motor when it is rotating.**
When a motor is rotating, clothes or fingers can be caught, resulting in an injury.
- **Do not drive a motor with an object such as a key exposed.**
An object such as a key can be thrown away, resulting in an injury. Before rotating a motor, check that there is no object that is thrown away by motor rotation.
- **Do not apply a radial load exceeding the "allowable radial load".**
The shaft can break, and components can be thrown away. When the vertical axis is involved, a vertical axis drop can occur.
- **To drive a motor, use a specified amplifier and parameters.**
An incorrect combination of a motor, amplifier, and parameters may cause the motor to behave unexpectedly. This is dangerous, and the motor may get damaged.
- **Do not bring any dangerous stuff near a motor.**
Motors are connected to a power line, and may get hot. If a flammable is placed near a motor, it may be ignited, catch fire, or explode.
- **Be safely dressed when handling a motor.**
Wear safety shoes or gloves when handling a motor as you may get hurt on any edge or protrusion on it or electric shocks.
- **Use a crane or lift to move a motor from one place to another.**
A motor is heavy, so that if you lift a motor by hand, you may be exposed to various risks. For example, the waist can be damaged, and the motor can drop to injure you. Use equipment such as a crane as needed. (For the weight of a motor, see Descriptions.)
- **Do not touch a motor when it is running or immediately after it stops.**
A motor may get hot when it is running. Do not touch the motor before it gets cool enough. Otherwise, you may get burned.
- **Be careful not get your hair or cloths caught in a fan.**
Be careful especially for a fan used to generate an inward air flow.
Be careful also for a fan even when the motor is stopped, because it continues to rotate while the amplifier is turned on.
- **Install the components around a motor securely.**
If a component is displaced or removed during motor rotation, a danger can result.

Caution

CAUTION

- **Use the eyebolt of a motor to move the motor only.**

When a motor is installed on a machine, do not move the machine by using the eyebolt of the motor. Otherwise, the eyebolt and motor can be damaged.

- **Do not disassemble a motor.**

Disassembling a motor may cause a failure or trouble in it.

If disassembly is in need because of maintenance or repair, please contact a service representative of FANUC.

For pulse coder replacement, refer to the Subsection, "Maintenance of a Detector".

- **Do not machine and modify a motor.**

Do not machine and modify a motor in any case except when motor machining or modification is specified by FANUC. Modifying a motor may cause a failure or trouble in it.

- **Do not conduct dielectric strength or insulation test for a sensor.**

Such a test can damage elements in the sensor.

- **Be sure to connect motor cables correctly.**

An incorrect connection of a cable cause abnormal heat generation, equipment malfunction, or failure. Always use a cable with an appropriate current carrying capacity (or thickness). Refer to the Specification manual of each motor for details of the connection method etc.

- **Do not apply shocks to a motor or cause scratches to it.**

If a motor is subjected to shocks or is scratched, its components may be adversely affected, resulting in normal operation being impaired. Plastic components and sensors can be damaged easily. So, handle those components very carefully. In particular, do not lift a motor by using a plastic component, connector, terminal block, and so forth.

- **Do not step or sit on a motor, and do not put a heavy object on a motor.**

If you step or sit on a motor, it may get deformed or broken. Do not put a motor on another unless they are in packages.

- **When attaching a component having inertia, such as a pulley, to a motor, ensure that any imbalance between the motor and component is minimized.**

If there is a large imbalance, the motor may vibrates abnormally, resulting in the motor being broken.

- **Be sure to attach a key to a motor with a keyed shaft.**

If a motor with a keyed shaft runs with no key attached, it may impair torque transmission or cause imbalance, resulting in the motor being broken.

- **Use a motor under an appropriate environmental condition.**

Using a motor in an adverse environment may cause a failure or trouble in it. Refer to Descriptions for details of the operating and environmental conditions for motors.

- **Do not apply a commercial power source voltage directly to a motor.**

Applying a commercial power source voltage directly to a motor may result in its windings being burned. Be sure to use a specified amplifier for supplying voltage to the motor.

CAUTION**- Do not use the brake built into a motor for braking.**

The brake built into a servo motor is designed for holding. If the brake is used for braking, a failure can occur.

- Ensure that motors are cooled if they are those that require forcible cooling.

If a motor that requires forcible cooling is not cooled normally, it may cause a failure or trouble. For a fan-cooled motor, ensure that it is not clogged or blocked with dust and dirt. For a liquid-cooled motor, ensure that the amount of the liquid is appropriate and that the liquid piping is not clogged. For both types, perform regular cleaning and inspection.

- When storing a motor, put it in a dry (non-condensing) place at room temperature (0 to 40 °C).

If a motor is stored in a humid or hot place, its components may get damaged or deteriorated. In addition, keep a motor in such a position that its shaft is held horizontal and its terminal box is at the top.

- FANUC motors are designed for use with machines. Do not use them for any other purpose.

If a FANUC motor is used for an unintended purpose, it may cause an unexpected symptom or trouble. If you want to use a motor for an unintended purpose, previously consult with FANUC.

Note**NOTE****- Ensure that a base or frame on which a motor is mounted is strong enough.**

Motors are heavy. If a base or frame on which a motor is mounted is not strong enough, it is impossible to achieve the required precision.

- Do not remove a nameplate from a motor.

If a nameplate comes off, be careful not to lose it. If the nameplate is lost, the motor becomes unidentifiable, resulting in maintenance becoming impossible.

- When testing the winding or insulation resistance of a motor, satisfy the conditions stipulated in IEC60034.

Testing a motor under a condition severer than those specified in IEC60034 may damage the motor.

- For a motor with a terminal box, make a conduit hole for the terminal box in a specified position.

When making a conduit hole, be careful not to break or damage unspecified portions. Refer to the Descriptions.

- Before using a motor, measure its winding and insulation resistances, and make sure they are normal.

Especially for a motor that has been stored for a prolonged period of time, conduct these checks. A motor may deteriorate depending on the condition under which it is stored or the time during which it is stored. For the winding resistances of motors, refer to the Descriptions, or ask FANUC. For insulation resistances, see the following table.

NOTE

- **To use a motor as long as possible, perform periodic maintenance and inspection for it, and check its winding and insulation resistances.**

Note that extremely severe inspections (such as dielectric strength tests) of a motor may damage its windings. For the winding resistances of motors, refer to the Descriptions, or ask FANUC. For insulation resistances, see the following table.

MOTOR INSULATION RESISTANCE MEASUREMENT

Measure an insulation resistance between each winding and motor frame using an insulation resistance meter (500 VDC). Judge the measurements according to the following table. Make an insulation resistance measurement on a single motor unit after detaching cords such as a power line.

Insulation resistance	Judgment
100 M Ω or higher	Acceptable
10 to 100 M Ω	The winding has begun deteriorating. There is no problem with the performance at present. Be sure to perform periodic inspection.
1 to 10 M Ω	The winding has considerably deteriorated. Special care is in need. Be sure to perform periodic inspection.
Lower than 1 M Ω	Unacceptable. Replace the motor.

FANUC SERVO AMPLIFIER β i series

Warnings and Cautions Relating to Mounting

Warning

WARNING

- **Check the specification code of the amplifier.**
Check that the delivered amplifier is as originally ordered.
- **Mount a ground fault interrupter.**
To guard against fire and electric shock, fit the factory power supply or machine with a ground fault interrupter (designed for use with an inverter).
- **Securely ground the amplifier.**
Securely connect the ground terminal and metal frame of the amplifier and motor to a common ground plate of the power magnetics cabinet.
- **Be aware of the weight of the amplifier and other components.**
Control motor amplifiers and AC reactors are heavy. When transporting them or mounting them in the cabinet, therefore, be careful not to injure yourself or damage the equipment. Be particularly careful not to jam your fingers between the cabinet and amplifier.
- **Never ground or short-circuit either the power supply lines or power lines.**
Protect the lines from any stress such as bending. Handle the ends appropriately.
- **Ensure that the power supply lines, power lines, and signal lines are securely connected.**
A loose screw, loose connection, or the like will cause a motor malfunction or overheating, or a ground fault.
Be extremely careful with power supply lines, motor power lines, and DC link connections through which a large amount of current passes, because a loose screw (or poor contact in a connector or poor connection between a connector terminal and a cable) may cause a fire.
- **Insulate all exposed parts that are charged.**
- **Never touch the regenerative discharge resistor or radiator directly.**
The surface of the radiator and regenerative discharge unit become extremely hot. Never touch them directly. An appropriate structure should also be considered.
- **Close the amplifier cover after completing the wiring.**
Leaving the cover open presents a danger of electric shock.
- **Do not disassemble the amplifier.**
- **Ensure that the cables used for the power supply lines and power lines are of the appropriate diameter and temperature ratings.**
- **Do not apply an excessively large force to plastic parts.**
If a plastic section breaks, it may cause internal damage, thus interfering with normal operation. The edge of a broken section is likely to be sharp and, therefore, presents a risk of injury.

Caution

CAUTION

- **Do not step or sit on the amplifier.**
Also, do not stack unpacked amplifiers on top of each other.
- **Use the amplifier in an appropriate environment.**
See the allowable ambient temperatures and other requirements, given in the corresponding descriptions.
- **Protect the amplifier from corrosive or conductive mist or drops of water.**
Use a filter if necessary.
- **Protect the amplifier from impact.**
Do not place anything on the amplifier.
- **Do not block the air inlet to the radiator.**
A deposit of coolant, oil mist, or chips on the air inlet will result in a reduction in the cooling efficiency. In some cases, the required efficiency cannot be achieved. The deposit may also lead to a reduction in the useful life of the semiconductors. Especially, when outside air is drawn in, mount filters on both the air inlet and outlet. These filters must be replaced regularly. So, an easy-to-replace type of filter should be used.
- **Connect the power supply lines and power lines to the appropriate terminals and connectors.**
- **Connect the signal lines to the appropriate connectors.**
- **Before connecting the power supply wiring, check the supply voltage.**
Check that the supply voltage is within the range specified in this manual, then connect the power supply lines.
- **Ensure that the combination of motor and amplifier is appropriate.**
- **Ensure that valid parameters are specified.**
Specifying an invalid parameter for the combination of motor and amplifier may not only prevent normal operation of the motor but also result in damage to the amplifier.
- **Ensure that the amplifier and peripheral equipment are securely connected.**
Check that the magnetic contactor, circuit breaker, and other devices mounted outside the amplifier are securely connected to each other and that those devices are securely connected to the amplifier.
- **Check that the amplifier is securely mounted in the power magnetics cabinet.**
If any clearance is left between the power magnetics cabinet and the surface on which the amplifier is mounted, dust entering the gap may build up and prevent the normal operation of the amplifier.
- **Apply appropriate countermeasures against noise.**
Adequate countermeasures against noise are required to maintain normal operation of the amplifier. For example, signal lines must be routed away from power supply lines and power lines.

Note

NOTE

- **Keep the nameplate clearly visible.**
- **Keep the legend on the nameplate clearly visible.**
- **After unpacking the amplifier, carefully check for any damage.**
- **Mount the amplifier in a location where it can be easily accessed periodic inspection and daily maintenance.**
- **Leave sufficient space around the machine to enable maintenance to be performed easily.**
Do not place any heavy objects such that they would interfere with the opening of the doors.
- **Keep the parameter table and spare parts at hand.**
Also, keep the specifications at hand. These items must be stored in a location where they can be retrieved immediately.
- **Provide adequate shielding.**
A cable to be shielded must be securely connected to the ground plate, using a cable clamp or the like.

Warnings and Cautions Relating to a Pilot Run

Warning

 WARNING

- **Before turning on the power, check that the cables connected to the power magnetics cabinet and amplifier, as well as the power lines and power supply lines, are securely connected. Also, check that no lines are slack.**
A loose screw, loose connection, or the like will cause a motor malfunction or overheating, or a ground fault. Be extremely careful with power supply lines, motor power lines, and DC link connections through which a large amount of current passes, because a loose screw (or poor contact in a connector or poor connection between a connector terminal and a cable) may cause a fire.
- **Before turning on the power, ensure that the power magnetics cabinet is securely grounded.**
- **Before turning on the power, check that the door of the power magnetics cabinet and all other doors are closed.**
Ensure that the door of the power magnetics cabinet containing the amplifier, and all other doors, are securely closed. During operation, all doors must be closed and locked.
- **Apply extreme caution if the door of the power magnetics cabinet or another door must be opened.**
Only a person trained in the maintenance of the corresponding machine or equipment should open the door, and only after shutting off the power supply to the power magnetics cabinet (by opening both the input circuit breaker of the power magnetics cabinet and the factory switch used to supply power to the cabinet). If the machine must be operated with the door open to enable adjustment or for some other purpose, the operator must keep his or her hands and tools well away from any dangerous voltages. Such work must be done only by a person trained in the maintenance of the machine or equipment.

⚠ WARNING

- **When operating the machine for the first time, check that the machine operates as instructed.**
To check whether the machine operates as instructed, first specify a small value for the motor, then increase the value gradually. If the motor operates abnormally, perform an emergency stop immediately.
- **After turning on the power, check the operation of the emergency stop circuit.**
Press the emergency stop button to check that the motor stops immediately, and that the power being supplied to the amplifier is shut off by the magnetic contactor.
- **Before opening a door or protective cover of a machine to enable adjustment of the machine, first place the machine in the emergency stop state and check that the motor has stopped.**

Caution**⚠ CAUTION**

- **Note whether an alarm status relative to the amplifier is displayed at power-up or during operation.**
If an alarm is displayed, take appropriate action as explained in the maintenance manual. If the work to be done requires that the door of the power magnetics cabinet be left open, the work must be carried out by a person trained in the maintenance of the machine or equipment. Note that if some alarms are forcibly reset to enable operation to continue, the amplifier may be damaged. Take appropriate action according to the contents of the alarm.
- **Before operating the motor for the first time, mount and adjust the position and speed sensors.**
Following the instructions given in the maintenance manual, adjust the position and speed sensors for the spindle so that an appropriate waveform is obtained.
If the sensors are not properly adjusted, the motor may not rotate normally or the spindle may fail to stop as desired.
- **If the motor makes any abnormal noise or vibration while operating, stop it immediately.**
Note that if operation is continued in spite of there being some abnormal noise or vibration, the amplifier may be damaged. Take appropriate corrective action, then resume operation.
- **Observe the ambient temperature and output rating requirements.**
The continuous output rating or continuous operation period of some amplifiers may fall as the ambient temperature increases. If the amplifier is used continuously with an excessive load applied, the amplifier may be damaged.
- **Unless otherwise specified, do not insert or remove any connector while the power is turned on. Otherwise, the amplifier may fail.**

Warnings and Cautions Relating to Maintenance

Warning

 WARNING
--

- **Read the maintenance manual carefully and ensure that you are totally familiar with its contents.**

The maintenance manual describes daily maintenance and the procedures to be followed in the event of an alarm being issued. The operator must be familiar with these descriptions.
- **Notes on replacing a fuse or PC board**
 - 1) Before starting the replacement work, ensure that the circuit breaker protecting the power magnetics cabinet is open.
 - 2) Check that the red LED that indicates that charging is in progress is not lit.

The position of the charging LED on each model of amplifier is given in this manual. While the LED is lit, hazardous voltages are present inside the unit, and thus there is a danger of electric shock.
 - 3) Some PC board components become extremely hot. Be careful not to touch these components.
 - 4) Ensure that a fuse having an appropriate rating is used.
 - 5) Check the specification code of a PC board to be replaced. If a modification drawing number is indicated, contact FANUC before replacing the PC board.

Also, before and after replacing a PC board, check its pin settings.
 - 6) After replacing the fuse, ensure that the screws are firmly tightened. For a socket-type fuse, ensure that the fuse is inserted correctly.
 - 7) After replacing the PC board, ensure that it is securely connected.
 - 8) Ensure that all power lines, power supply lines, and connectors are securely connected.
- **Take care not to lose any screws.**

When removing the case or PC board, take care not to lose any screws. If a screw is lost inside the nit and the power is turned on, the machine may be damaged.
- **Notes on replacing the battery of the absolute pulse coder**

Replace the battery only while the power is on. If the battery is replaced while the power is turned off, the stored absolute positioning data will be lost. If the battery is installed in the βi series servo amplifier, open the door of the power magnetics cabinet and enter the emergency stop state without turning off the control power. Interrupt the input of the power system of the amplifier and then replace the battery. Replacement work should be done only by a person who is trained in the related maintenance and safety requirements. The power magnetics cabinet in which the servo amplifier is mounted has a high-voltage section. This section presents a severe risk of electric shock.
- **Check the number of any alarm.**

If the machine stops upon an alarm being issued, check the alarm number. Some alarms indicate that a component must be replaced. If the power is reconnected without first replacing the failed component, another component may be damaged, making it difficult to locate the original cause of the alarm.
- **Before resetting an alarm, ensure that the original cause of the alarm has been removed.**
- **Contact FANUC whenever a question relating to maintenance arises.**
- **Notes on removing the amplifier**

Before removing the amplifier, first ensure that the power is shut off. Be careful not to jam your fingers between the power magnetics cabinet and amplifier.

Caution

CAUTION

- **Tighten all screws firmly.**
- **Check the specification code of the fuse, PC board, and other components.**
When replacing a fuse or PC board, first check the specification code of the fuse or PC board, then mount it in the correct position. The machine will not operate normally if a fuse or PC board having other than the correct specification code is mounted, or if a fuse or PC board is mounted in the wrong position.
- **Mount the correct cover.**
The cover on the front of the amplifier carries a label indicating a specification code. When mounting a previously removed front cover, take care to mount it on the unit from which it was removed.
- **Notes on cleaning the heat sink and fan**
 - 1) A dirty heat sink or fan results in reduced semiconductor cooling efficiency, which degrades reliability. Periodic cleaning is necessary.
 - 2) Using compressed air for cleaning scatters the dust. A deposit of conductive dust on the amplifier or peripheral equipment will result in a failure.
 - 3) To clean the heat sink, do so only after turning the power off and ensuring that the heat sink has cooled to room temperature. The heat sink becomes extremely hot, such that touching it during operation or immediately after power-off is likely to cause a burn. Be extremely careful when touching the heat sink.

Note

NOTE

- **Ensure that the battery connector is correctly inserted.**
If the power is shut off while the battery connector is not connected correctly, the absolute position data for the machine will be lost.
- **Store the manuals in a safe place.**
The manuals should be stored in a location where they can be accessed immediately if so required during maintenance work.
- **Notes on contacting FANUC**
Inform FANUC of the details of an alarm and the specification code of the amplifier so that any components required for maintenance can be quickly secured, and any other necessary action can be taken without delay.

JR AUTOMATION TECHNOLOGIES INC*
JDOWLING

PREFACE

Organization of this manual

This manual describes information necessary to maintain FANUC SERVO AMPLIFIER βi series products, such as a βiSV and $\beta iSVSP$ and FANUC SERVO MOTOR βi series and FANUC SPINDLE MOTOR βi series products.

Parts I and II explain the start-up procedure and troubleshooting for the βi series βiSV .

Parts III and IV explain the start-up procedure and troubleshooting for the βi series $\beta iSVSP$.

Parts V and VI explain the maintenance for servo motor βi series and spindle motor βi series.

The abbreviations listed below are used in this manual.

Product name	Abbreviations
FANUC Series 30i-MODEL B	FS 30i-B
FANUC Series 31i-MODEL B	FS 31i-B
FANUC Series 32i-MODEL B	FS 32i-B
FANUC Series 35i-MODEL B	FS 35i-B
FANUC Series Power Motion i -MODEL A	FS PM <i>i</i> -A
FANUC Series 30i-MODEL A	FS 30i-A
FANUC Series 31i-MODEL A	FS 31i-A
FANUC Series 32i-MODEL A	FS 32i-A
FANUC Series 0i/0i Mate-MODEL D	FS 0i/0i Mate-D
FANUC Series 0i/0i Mate-MODEL C	FS 0i/0i Mate-C
FANUC Series 0i/0i Mate-MODEL B	FS 0i/0i Mate-B
FANUC Series 15i	FS15i
FANUC Series 16i	FS16i
FANUC Series 18i	FS18i
FANUC Series 21i	FS21i
FANUC Power Mate i -MODEL D	PMi
FANUC Power Mate i -MODEL H	
FANUC SERVO AMPLIFIER βi series βiSV	βi SV
FANUC SERVO AMPLIFIER βi series $\beta iSVSP$	βi SVSP

* In this manual, the parameter numbers of servo parameters are sometimes indicated without CNC product names as follows:

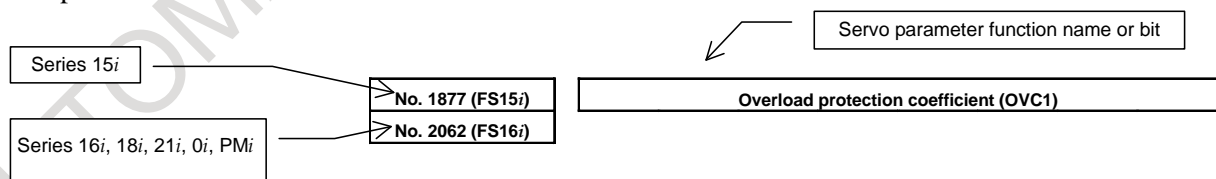

* The manuals shown below provide information related to this manual. This manual may refer you to these manuals.

- 1) FANUC SERVO AMPLIFIER βi series DESCRIPTIONS B-65322EN
- 2) FANUC AC SERVO MOTOR βi series DESCRIPTIONS B-65302EN
- 3) FANUC AC SPINDLE MOTOR βi series DESCRIPTIONS B-65312EN
- 4) FANUC AC SERVO MOTOR αi series/FANUC AC SERVO MOTOR βi series,
FANUC LINEAR MOTOR LiS series, FANUC SYNCHRONOUS BUILT-IN SERVO
MOTOR DiS series PARAMETER MANUAL B-65270EN
- 5) FANUC AC SPINDLE MOTOR $\alpha i/\beta i$ series, BUILT-IN SPINDLE MOTOR Bi series
PARAMETER MANUAL B-65280EN

JR AUTOMATION TECHNOLOGIES INC*
JDOWLING

TABLE OF CONTENTS

SAFETY PRECAUTIONS	s-1
DEFINITION OF WARNING, CAUTION, AND NOTE	s-2
FANUC AC SERVO MOTOR βi series, FANUC AC SPINDLE MOTOR βi series ..	s-3
Warning	s-3
Caution.....	s-5
Note.....	s-6
FANUC SERVO AMPLIFIER βi series	s-8
Warnings and Cautions Relating to Mounting	s-8
Warning	s-8
Caution	s-9
Note	s-10
Warnings and Cautions Relating to a Pilot Run	s-10
Warning	s-10
Caution	s-11
Warnings and Cautions Relating to Maintenance.....	s-12
Warning	s-12
Caution	s-13
Note	s-13
PREFACE	p-1
I. START-UP PROCEDURE FOR βiSV	
1 OVERVIEW	3
2 CONFIGURATIONS	4
2.1 CONFIGURATIONS	4
2.2 MAJOR COMPONENTS	5
2.2.1 Servo Amplifier	5
3 START-UP PROCEDURE	6
3.1 START-UP PROCEDURE (OVERVIEW)	6
3.2 CONNECTING THE POWER	7
3.2.1 Checking the Voltage and Capacity of the Power	7
3.2.2 Connecting a Protective Ground	8
3.2.3 Selecting the Ground Fault Interrupter That Matches the Leakage Current	8
3.3 INITIALIZING PARAMETERS (SWITCHES AND DUMMY CONNECTORS) ..	9
3.4 INITIALIZING SETTINGS	9
4 CONFIRMATION OF THE OPERATION	10
4.1 SERVO AMPLIFIER MODULE	10
4.1.1 Check Procedure.....	10
4.1.2 VRDY-OFF Alarm Indicated on the CNC Screen	12
4.1.3 Method for Observing Motor Current	14
II. TROUBLESHOOTING FOR βiSV	
1 OVERVIEW	19
2 ALARM NUMBERS AND BRIEF DESCRIPTIONS	20

2.1	FOR Series 30 <i>i</i> /31 <i>i</i> /32 <i>i</i> /35 <i>i</i> -B, Power Motion <i>i</i> -A	20
2.1.1	Servo Alarm	20
2.2	FOR Series 30 <i>i</i> /31 <i>i</i> /32 <i>i</i> -A	20
2.2.1	Servo Alarm	20
2.3	FOR Series 0 <i>i</i> /0 <i>i</i> Mate-D	21
2.3.1	Servo Alarm	21
2.4	FOR Series 15 <i>i</i>	22
2.4.1	Servo Alarm	22
2.5	FOR Series 16 <i>i</i> , 18 <i>i</i> , 20 <i>i</i> , 21 <i>i</i> , 0 <i>i</i> , AND Power Mate <i>i</i>	23
2.5.1	Servo Alarm	23
3	TROUBLESHOOTING AND ACTION	24
3.1	SERVO AMPLIFIER MODULE	24
3.1.1	Converter: DC Link Undervoltage	24
3.1.2	Converter: DC Link Overvoltage	25
3.1.3	Converter: Excessive Deceleration Power	25
3.1.4	Converter: Control Power Supply Undervoltage	26
3.1.5	Inverter: Internal Cooling Fan Stopped	26
3.1.6	Inverter: Cooling Fan Stopped of the Radiator	26
3.1.7	Inverter: IPM Alarm	26
3.1.8	Inverter: IPM Alarm (OH)	27
3.1.9	Inverter: Motor Current Alarm	27
3.1.10	FSSB Communication Error	28
3.2	SERVO SOFTWARE	28
3.2.1	Servo Adjustment Screen	28
3.2.2	Diagnosis Screen	30
3.2.3	Overload Alarm (Soft Thermal, OVC)	30
3.2.4	Feedback Disconnected Alarm	31
3.2.5	Overheat Alarm	32
3.2.6	Invalid Servo Parameter Setting Alarm	32
3.2.7	Alarms Related to Pulsecoder and Separate Serial Detector	33
3.2.8	Other Alarms	34
4	REPLACING SERVO AMPLIFIER COMPONENTS	36
4.1	REPLACEMENT OF A FAN MOTOR	36
4.1.1	For the Internal Cooling Fan Motor: β iSV4, β iSV20	36
4.1.2	For the Internal Cooling Fan Motor: β iSV40, β iSV80, β iSV10HV, β iSV20HV, β iSV40HV	37
4.1.3	For the Internal Cooling Fan Motor: β iSV20/20, β iSV40/40	38
4.1.4	For the Radiator Cooling Fan Motor: β iSV40, β iSV80, β iSV10HV, β iSV20HV, β iSV40HV	39
4.2	REPLACING BATTERY FOR ABSOLUTE PULSECODERS	40
4.2.1	Overview	40
4.2.2	Replacing Batteries	40
4.2.3	Replacing the Batteries in a Separate Battery Case	41
4.2.4	Replacing the Battery Built into the Servo Amplifier	41
4.2.5	Notes on Replacing a Battery (Supplementary Explanation)	43
4.2.5.1	Battery connection modes	43
4.2.5.2	Connecting the battery for the β series motor	45
4.2.5.3	Notes on attaching connectors	45
4.3	HOW TO REPLACE THE FUSES AND PRINTED CIRCUIT BOARDS	47
4.3.1	How to Replace the Fuses and Printed Circuit Boards	47
4.3.2	Fuse Locations	50

III. START-UP PROCEDURE FOR βi SVSP

1	OVERVIEW	53
2	CONFIGURATIONS	54
2.1	CONFIGURATIONS	54
2.2	MAJOR COMPONENTS	55
2.2.1	βi SVSP	55
2.2.2	βi SVSPc	56
3	START-UP PROCEDURE	57
3.1	START-UP PROCEDURE (OVERVIEW)	57
3.2	CONNECTING THE POWER	58
3.2.1	Checking the Voltage and Capacity of the Power	58
3.2.2	Connecting a Protective Ground	60
3.2.3	Selecting the Ground Fault Interrupter That Matches the Leakage Current	60
3.3	INITIALIZING PARAMETERS	61
4	CONFIRMATION OF THE OPERATION	62
4.1	OUTLINE OF βi SVSP	62
4.1.1	Connector and STATUS LED Locations	62
4.1.2	Start-up Procedure	65
4.2	βi SVSP COMMON POWER SUPPLY UNIT	66
4.2.1	The LED (STATUS Indicator) Is Off.	66
4.2.2	Checking Method when Magnetic Contactor Is not Switched On	66
4.2.3	Check Terminal on the Printed-circuit Board	67
4.3	βi SVSP SPINDLE UNIT	68
4.3.1	STATUS 1 Indicator	68
4.3.2	Troubleshooting at Startup	69
4.3.2.1	The STATUS 1 indicator is blinking with "--."	69
4.3.2.2	The motor does not turn	69
4.3.2.3	A specified speed cannot be obtained	69
4.3.2.4	When cutting is not performed, the spindle vibrates, making noise.	70
4.3.2.5	An overshoot or hunting occurs	70
4.3.2.6	Cutting power weakens or acceleration/deceleration slows down	70
4.3.3	Status Error Indication Function	71
4.3.4	Observing Data Using the SERVO GUIDE	74
4.3.4.1	Overview	74
4.3.4.2	Usable series and editions	74
4.3.4.3	List of spindle data that can be observed using the SERVO GUIDE	75
4.3.4.4	About the spindle control and spindle status signals	76
4.3.4.5	Example of observing data	77
4.3.5	Spindle Check Board	78
4.3.5.1	Spindle check board specifications	78
4.3.5.2	Spindle check board connection	78
4.3.5.3	Check terminal output signals	78
4.3.6	Checking the Feedback Signal Waveform	80
4.3.6.1	αi M sensor, αi MZ sensor, and αi BZ sensor	80
4.3.6.2	αi CZ sensor	81
4.3.6.3	α position coder S	81
4.4	βi SVSP SERVO UNIT	82
4.4.1	Checking the STATUS 2 Indicator	82
4.4.2	VRDY-OFF Alarm Indicated on the CNC Screen	82

4.4.3	Method for Observing Motor Current	84
-------	--	----

IV. TROUBLESHOOTING FOR β iSVSP

1	OVERVIEW	89
2	ALARM NUMBERS AND BRIEF DESCRIPTIONS	90
2.1	For Series 0i/0i Mate-D	90
2.1.1	Servo Alarm	90
2.1.2	Spindle Alarm.....	91
2.2	For Series 0i/0i Mate-B,C	93
2.2.1	Servo Alarm	93
2.2.2	Spindle Alarm.....	94
3	TROUBLESHOOTING AND ACTION.....	96
3.1	COMMON TO SERVO AND SPINDLE UNITS	96
3.1.1	STATUS2 Alarm Code - STATUS1 Alarm Code 04 (SP9004)	96
3.1.2	STATUS2 Alarm Code - STATUS1 Alarm Code 11 (SP9011)	96
3.1.3	STATUS2 Alarm Code - STATUS1 Alarm Code 30 (SP9030)	96
3.1.4	STATUS2 Alarm Code - STATUS1 Alarm Code 33 (SP9033)	96
3.1.5	STATUS2 Alarm Code - STATUS1 Alarm Code 51 (SP9051)	97
3.1.6	STATUS2 Alarm Code - STATUS1 Alarm Code 58 (SP9058)	97
3.1.7	STATUS2 Alarm Code - STATUS1 Alarm Code 59 (SP9059)	97
3.1.8	STATUS2 Alarm Code - STATUS1 Alarm Code b1 (SP9111)	98
3.2	SERVO UNIT.....	98
3.2.1	STATUS2 Alarm Code 1 (SV0444).....	99
3.2.2	STATUS2 Alarm Code 2 (SV0434).....	99
3.2.3	STATUS2 Alarm Code 5 (SV0435).....	99
3.2.4	STATUS2 Alarm Code 6 (SV0602).....	99
3.2.5	STATUS2 Alarm Code P (SV0604)	100
3.2.6	STATUS2 Alarm Code 8. , 9. , A. (SV0449).....	100
3.2.7	STATUS2 Alarm Code 8. , 9. , A. (SV0603).....	100
3.2.8	STATUS2 Alarm Code b , c , d (SV0438).....	100
3.2.9	Alarm Code "-" Flashing	101
3.2.10	STATUS2 Alarm Code U	102
3.2.11	Alarm Code L.....	103
3.3	SERVO SOFTWARE.....	103
3.3.1	Servo Tuning Screen	103
3.3.2	Diagnosis Screen	104
3.3.3	Overload Alarm (Soft Thermal, OVC).....	105
3.3.4	Feedback Disconnected Alarm.....	106
3.3.5	Overheat Alarm	106
3.3.6	Invalid Servo Parameter Setting Alarm.....	107
3.3.7	Alarms Related to Pulsecoder and Separate Serial Detector	107
3.3.8	Other Alarms	109
3.4	SPINDLE UNIT.....	110
3.4.1	Alarm Code 01 (SP9001)	110
3.4.2	Alarm Code 02 (SP9002)	111
3.4.3	Alarm Code 03 (SP9003)	111
3.4.4	Alarm Code 06 (SP9006)	112
3.4.5	Alarm Code 07 (SP9007)	112
3.4.6	Alarm Code 09 (SP9009)	112
3.4.7	Alarm Code 10 (SP9010)	113
3.4.8	Alarm Code 12 (SP9012)	113

3.4.9	Alarm Code 13 (SP9013)	114
3.4.10	Alarm Code 14 (SP9014)	114
3.4.11	Alarm Code 15 (SP9015)	114
3.4.12	Alarm Code 16 (SP9016)	114
3.4.13	Alarm Code 17 (SP9017)	115
3.4.14	Alarm Code 18 (SP9018)	115
3.4.15	Alarm Codes 19 and 20 (SP9019, SP9020)	115
3.4.16	Alarm Code 21 (SP9021)	115
3.4.17	Alarm Code 22 (SP9022)	115
3.4.18	Alarm Code 24 (SP9024)	115
3.4.19	Alarm Code 27 (SP9027)	116
3.4.20	Alarm Code 29 (SP9029)	117
3.4.21	Alarm Code 31 (SP9031)	118
3.4.22	Alarm Code 32 (SP9032)	118
3.4.23	Alarm Code 34 (SP9034)	118
3.4.24	Alarm Code 35 (SP9035)	119
3.4.25	Alarm Code 36 (SP9036)	119
3.4.26	Alarm Code 37 (SP9037)	120
3.4.27	Alarm Code 41 (SP9041)	120
3.4.28	Alarm Code 42 (SP9042)	121
3.4.29	Alarm Code 43 (SP9043)	121
3.4.30	Alarm Code 46 (SP9046)	121
3.4.31	Alarm Code 47 (SP9047)	121
3.4.32	Alarm Code 49 (SP9049)	122
3.4.33	Alarm Code 50 (SP9050)	122
3.4.34	Alarm Codes 52 and 53 (SP9052, SP9053)	122
3.4.35	Alarm Code 54 (SP9054)	122
3.4.36	Alarm Code 55 (SP9055)	123
3.4.37	Alarm Code 56 (SP9056)	123
3.4.38	Alarm Code 61 (SP9061)	123
3.4.39	Alarm Code 66 (SP9066)	124
3.4.40	Alarm Code 67 (SP9067)	124
3.4.41	Alarm Code 68 (SP9068)	124
3.4.42	Alarm Code 69 (SP9069)	124
3.4.43	Alarm Code 70 (SP9070)	124
3.4.44	Alarm Code 71 (SP9071)	124
3.4.45	Alarm Code 72 (SP9072)	125
3.4.46	Alarm Code 73 (SP9073)	125
3.4.47	Alarm Code 74 (SP9074)	126
3.4.48	Alarm Code 75 (SP9075)	126
3.4.49	Alarm Code 76 (SP9076)	126
3.4.50	Alarm Code 77 (SP9077)	126
3.4.51	Alarm Code 78 (SP9078)	126
3.4.52	Alarm Code 79 (SP9079)	126
3.4.53	Alarm Code 81 (SP9081)	126
3.4.54	Alarm Code 82 (SP9082)	127
3.4.55	Alarm Code 83 (SP9083)	128
3.4.56	Alarm Code 84 (SP9084)	128
3.4.57	Alarm Code 85 (SP9085)	129
3.4.58	Alarm Code 86 (SP9086)	129
3.4.59	Alarm Code 87 (SP9087)	129
3.4.60	Alarm Code 88 (SP9088)	129
3.4.61	Alarm Code 92 (SP9092)	129
3.4.62	Alarm Codes A, A1,A2	130
3.4.63	Alarm Code b0 (SP9110)	130

3.4.64	Alarm Codes C0, C1, and C2 (SP9120, SP9121, and SP9122)	130
3.4.65	Alarm Code C3 (SP9123)	130
3.4.66	Alarm Code C8 (SP9128)	131
3.4.67	Alarm Code C9 (SP9129)	131
3.4.68	Alarm Code d1 (SP9131)	131
3.4.69	Alarm Code d2 (SP9132)	131
3.4.70	Alarm Code d3 (SP9133)	131
3.4.71	Alarm Code d4 (SP9134)	132
3.4.72	Alarm Code d6 (SP9136)	132
3.4.73	Alarm Code d7 (SP9137)	132
3.4.74	Alarm Code d8 (SP9138)	132
3.4.75	Alarm Code d9 (SP9139)	132
3.4.76	Alarm Code E0 (SP9140)	132
3.4.77	Alarm Code E1 (SP9141)	133
3.4.78	Alarm Code E2 (SP9142)	133
3.4.79	Alarm Code F8 (SP9158)	133
3.4.80	Alarm Code G6 (SP9166)	133
3.4.81	Alarm Code G7 (SP9167)	133
3.4.82	Other Alarms	134

4 REPLACING SERVO AMPLIFIER COMPONENTS 135

4.1	REPLACEMENT OF A FAN MOTOR	135
4.1.1	For the Internal Cooling Fan Motor: Model β iSVSP*-18 Only	135
4.1.2	External Cooling Fan Motor	136
4.2	REPLACING BATTERY FOR ABSOLUTE PULSECODERS	137
4.2.1	Overview	137
4.2.2	Replacing Batteries	137
4.2.3	Replacing the Batteries in a Separate Battery Case	138
4.2.4	Replacing the Battery Built into the Servo Amplifier	138
4.2.5	Notes on Replacing a Battery (Supplementary Explanation)	140
4.2.5.1	Battery connection modes	140
4.2.6	Notes on Attaching Connectors	142
4.3	HOW TO REPLACE THE FUSES AND PRINTED CIRCUIT BOARDS....	143
4.3.1	How to Replace the Fuses and Printed Circuit Boards	143
4.3.2	Fuse Locations	144

V. MOTOR/DETECTOR/AMPLIFIER PREVENTIVE MAINTENANCE

1 MOTOR/DETECTOR/AMPLIFIER PREVENTIVE MAINTENANCE ... 147

1.1	LIST OF MANUALS RELATED TO MOTORS AND AMPLIFIERS	148
1.2	PREVENTIVE MAINTENANCE OF MOTORS AND DETECTORS	149
1.2.1	Warnings, Cautions, and Notes on Preventive Maintenance of Motors and Detectors	149
1.2.2	Preventive Maintenance of a Motor (Common to All Models)	151
1.2.2.1	Main inspection items	151
1.2.2.2	Periodic cleaning of a motor	154
1.2.2.3	Notes on motor cleaning	154
1.2.2.4	Notes on the cutting fluid (informational)	154
1.2.3	Preventive Maintenance of a Linear Motor	155
1.2.3.1	Appearance inspection of the linear motor (magnet plate)	155
1.2.4	Maintenance of a Detector	155
1.2.4.1	Alarms for built-in detectors (α i and β i Pulsecoders) and troubleshooting actions	156
1.2.4.2	Alarms for separate detectors and troubleshooting actions	156

	1.2.4.3	Detailed troubleshooting methods	158
	1.2.4.4	Maintenance of β iS servo motor (\square 40 and \square 60) Pulsecoders	159
1.3		PREVENTIVE MAINTENANCE OF SERVO AMPLIFIERS	160
	1.3.1	Warnings, Cautions, and Notes on Operation of Servo Amplifiers	160
	1.3.2	Preventive Maintenance of a Servo Amplifier	163
	1.3.3	Maintenance of a Servo Amplifier	164
	1.3.3.1	Display of the servo amplifier operation status	164
	1.3.3.2	Replacement of a fan motor.....	164
1.4		REPLACING BATTERY FOR ABSOLUTE PULSECODERS.....	164

VI. MOTOR MAINTENANCE

1		SERVO MOTOR MAINTENANCE	167
	1.1	SERVO MOTOR MAINTENANCE PARTS	167
	1.1.1	Pulsecoder	167
2		SPINDLE MOTOR MAINTENANCE PARTS	168
	2.1	SPINDLE MOTOR MAINTENANCE PARTS	168

APPENDIX

A		MEASURING SERVO MOTOR WAVEFORMS (TCMD, VCMD)	171
B		USING THE SPINDLE CHECK BOARD	173
	B.1	OBSERVING DATA USING THE SPINDLE CHECK BOARD	173
	B.1.1	Overview	173
	B.1.2	Main Characteristics	173
	B.1.3	Observation Method	173
	B.1.4	Setting Data to Be Observed	173
	B.1.5	Descriptions and Initial Values of Addresses.....	174
	B.1.6	Principles in Outputting the Internal Data of the Spindle	174
	B.1.7	Data Numbers	177
	B.1.8	Examples of Observing Data.....	178
	B.2	CHECKING PARAMETERS USING THE SPINDLE CHECK BOARD	179
	B.2.1	Overview	179
	B.2.1.1	Checking parameters	179

ADDITIONAL INFORMATION

JR AUTOMATION TECHNOLOGIES INC*
JDOWLING

I. START-UP PROCEDURE FOR β iSV

JR AUTOMATION TECHNOLOGIES INC*
JDOWLING

JR AUTOMATION TECHNOLOGIES INC*
JDOWLING

1 OVERVIEW

This part describes the units and components of the servo amplifiers. It also explains the following information necessary to start up the servo amplifier:

- Configurations
- Start-up procedure
- Confirmation of the operation
- Periodic maintenance of servo amplifier

JR AUTOMATION TECHNOLOGIES INC*
JDOWLING

2 CONFIGURATIONS

2.1 CONFIGURATIONS

The servo amplifier βiSV consists of the units and components listed below:

- | | |
|--|----------|
| (1) Servo amplifier module (βiSV) | (basic) |
| (2) AC line filter | (basic) |
| (3) Connectors (for connecting cables) | (basic) |
| (4) Fuses | (option) |
| (5) Power transformer | (option) |

Constituent (example)

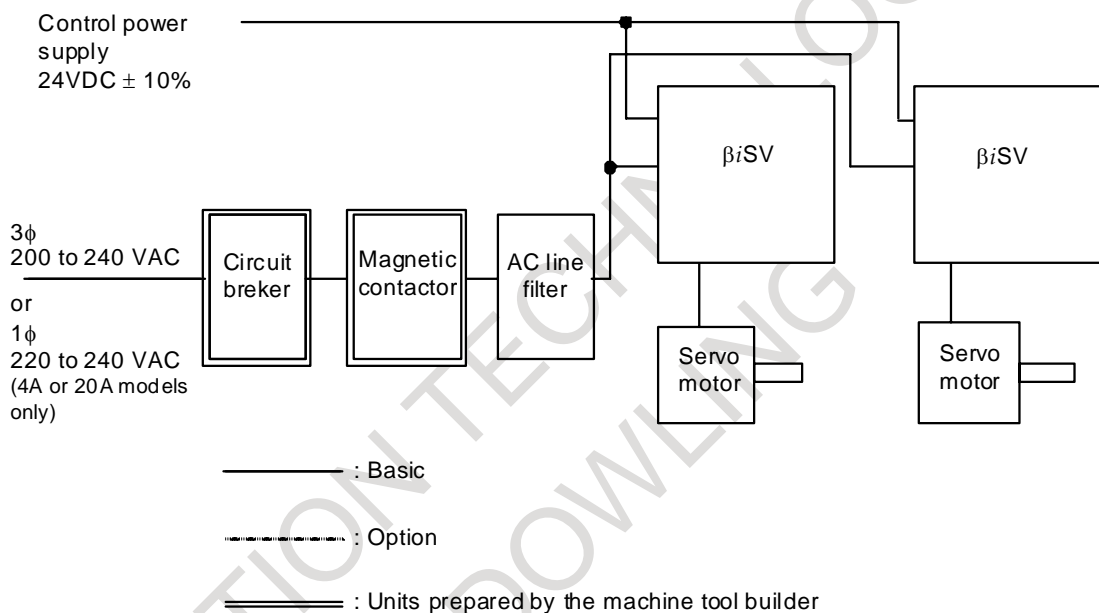

NOTE

- 1 Be sure to use a stabilized power supply as the 24VDC amplifier power supply. Do not use the 24VDC motor brake power supply as the 24VDC amplifier power supply.
- 2 A circuit breakers , magnetic contactor, and AC line filter are always required.
- 3 To protect the unit from surge currents caused by lightning, connect surge absorbers between lines, and between the lines and ground, at the power inlet of the power magnetics cabinet.

⚠ WARNING

Take great care to prevent incorrect operation of the motor or a ground fault caused by looseness of a screw, incorrect insertion of a connector, etc.
Take great care to prevent fire caused by looseness of a screw (or incorrect contact with a connector or incorrect connection between a connector terminal and a cable) in a power line or motor power line through which large current flows.

2.2 MAJOR COMPONENTS

2.2.1 Servo Amplifier

(1) 1-axis β iSV series (200-V type)

Model	Order specification	Unit specification	Wiring board specification	Printed circuit board specification
β iSV4	A06B-6130-H001	A06B-6130-C001	A20B-2101-0090	A20B-2101-0050
β iSV20	A06B-6130-H002	A06B-6130-C002	A20B-2101-0091	
β iSV40	A06B-6130-H003	A06B-6130-C003	A16B-3200-0512	A20B-2101-0051
β iSV80	A06B-6130-H004	A06B-6130-C004	A16B-3200-0513	

(2) 1-axis β iSV series for 30i-B series CNC (200-V type)

Model	Order specification	Unit specification	Wiring board specification	Printed circuit board specification
β iSV4	A06B-6160-H001	A06B-6160-C001	A20B-2101-0090	A20B-2102-0081
β iSV20	A06B-6160-H002	A06B-6160-C002	A20B-2101-0091	
β iSV40	A06B-6160-H003	A06B-6160-C003	A16B-3200-0512	
β iSV80	A06B-6160-H004	A06B-6160-C004	A16B-3200-0513	

(3) 1-axis β iSV series (400-V type)

Model	Order specification	Unit specification	Wiring board specification	Printed circuit board specification
β iSV10HV	A06B-6131-H001	A06B-6131-C001	A16B-3200-0515	A20B-2101-0051
β iSV20HV	A06B-6131-H002	A06B-6131-C002	A16B-3200-0516	
β iSV40HV	A06B-6131-H003	A06B-6131-C003	A16B-3200-0517	

(4) 1-axis β iSV series for 30i-B series CNC (400-V type)

Model	Order specification	Unit specification	Wiring board specification	Printed circuit board specification
β iSV10HV	A06B-6161-H001	A06B-6161-C001	A16B-3200-0515	A20B-2102-0081
β iSV20HV	A06B-6161-H002	A06B-6161-C002	A16B-3200-0516	
β iSV40HV	A06B-6161-H003	A06B-6161-C003	A16B-3200-0517	

(5) 2-axis β iSV series (200-V type)

Model	Order specification	Unit specification	Wiring board specification	Printed circuit board specification
β iSV20/20	A06B-6136-H201	A06B-6136-C201	A16B-3200-0642	A20B-2101-0290
β iSV40/40	A06B-6136-H203	A06B-6136-C203	A16B-3200-0643	

(6) 2-axis β iSV series for 30i-B series CNC (200-V type)

Model	Order specification	Unit specification	Wiring board specification	Printed circuit board specification
β iSV20/20	A06B-6166-H201	A06B-6166-C201	A16B-3200-0642	A20B-2101-0881
β iSV40/40	A06B-6166-H203	A06B-6166-C203	A16B-3200-0643	

3 START-UP PROCEDURE

3.1 START-UP PROCEDURE (OVERVIEW)

Make sure that the specifications of the CNC, servo motors, servo amplifiers, and other units you received are exactly what you ordered, and these units are connected correctly. Then, turn on the power. The items to be checked are described below.

No.	Description	Check method
Checking the installation of the servo amplifier		
1	Specification of the servo amplifier and servo motor	Check the combination of the servo amplifier and the servo motor is correct. Refer to the Servo Amplifier β i series Descriptions (B-65322EN).
2	Packing of the flange	Check the supplied packing is attached properly and that there is no gap between the control panel and the amplifier flange.
3	Keeping maintenance areas	Keep maintenance areas above and below the amplifier. For details, refer to the Servo Amplifier β i series Descriptions (B-65322EN).
4	Prevention of contact with conductive section	Check a protective plate is attached to the DC link terminal board. For details, refer to the Servo Amplifier β i series Descriptions (B-65322EN).
5	Measure against entry of coolant	Take a measure to prevent electroconductive, flammable, and corrosive material as well as mist and water drop from getting in the unit. For keeping of the effective closeness of the control panel, refer to Appendix G "EXAMPLES OF RECOMMENDED POWER MAGNETICS CABINETS FOR SERVO AMPLIFIER INSTALLATION" in the α i series Servo Amplifier Descriptions" (B-65412EN).
Checking the wiring for the servo amplifier		
6	Screwing to the terminal block	When connecting wires to the servo amplifier terminal board, be sure to tighten the screws with a proper torque. For the detail of the tightening torque for the terminal board screws, refer to the Servo Amplifier β i series Descriptions (B-65322EN).
7	Connecting protective ground	Use a proper cable for grounding in order to prevent electrical shocks at a ground fault. For details, refer to Subsection 9.3.1.7 of the Servo Amplifier β i series Descriptions" (B-65322EN).
8	Installing the lightning surge protector	In order to prevent damage due to a surge voltage applied to the input power supply, install a lightning surge protector. For details, refer to the Servo Amplifier β i series Descriptions" (B-65322EN).
9	Measure against noise	Check that ground wires, including feedback cable shielding clamps, are connected to proper places to maintain a stable operation of the machine. For details, refer to the Servo Amplifier β i series Descriptions" (B-65322EN).
10	Phase order of motor power lines	If the phase order of motor power lines is incorrect, the motor may operate unexpectedly. Make sure that the motor power lines are connected correctly.
11	Checking the axis to which the motor feedback wire and power wire are connected	If the axis to which the motor feedback wire and power wire are connected is incorrect, the motor may operate unexpectedly. So, make sure that the connection is correct.
12	Connection of batteries	Do not connect the built-in batteries in parallel. Please make sure, if the built-in batteries are used with an amp-to-amp battery connection cable (CXA19A/B or BATL (B3)) attached, they may be connected in parallel. For details, refer to the Servo Amplifier β i series Descriptions" (B-65322EN).
Check during startup of operation		
13	Checking the power supply voltage	Before turning on the power, check that the power supply voltage is in its proper range. For details of the power supply voltage specification, refer to the Servo Amplifier β i series Descriptions" (B-65322EN).
14	Checking the ground potential	The 400 V servo amplifier supports only neutral grounding. For details, refer to the Servo Amplifier β i series Descriptions" (B-65322EN).

No.	Description	Check method
15	Setting the ground fault breaker	Use a ground fault interrupter that supports inverters. For information about leakage current, refer to the Servo Amplifier βi series Descriptions (B-65322EN).
16	Checking the control power	Check that the voltage of the 24 V power supply for amplifiers is in its proper range and the selected current capacity is proper. For details, refer to the Servo Amplifier βi series Descriptions (B-65322EN).
17	Setting parameters	Set initial parameters with reference to Section 3.4.
18	Handling early failures	To solve start-up problems, such as being impossible to turn on the power, motor failing to rotate, and occurrence of an alarm, see Chapter 5 of this document.

3.2 CONNECTING THE POWER

3.2.1 Checking the Voltage and Capacity of the Power

Before connecting the power, you should measure the AC power voltage.

- (1) 1-axis βiSV series (200-V type), 2-axis βiSV series (200-V type)

Table 3.2.1 (a) Action for the AC power (200-V input type)

Permissible voltage fluctuation width	Nominal voltage	Action
-15%+10%	3-phase 200 to 240VAC	<u>$\beta iSV4$, $\beta iSV 20$, $\beta iSV 40$, $\beta iSV 80$, $\beta iSV 20/20$, $\beta iSV 40/40$</u> Permitted. Note) If the voltage is below the rated value, the rated output may not be obtained.
-15%+10%	1-phase 220 to 240VAC	<u>$\beta iSV4$, $\beta iSV 20$</u> Single-phase input is permitted when the power supply is 380 to 415 VAC to neutral grounding.
Other than the above		<u>$\beta iSV4$, $\beta iSV 20$, $\beta iSV 40$, $\beta iSV 80$, $\beta iSV 20/20$, $\beta iSV 40/40$</u> Not permitted. Use an insulating transformer to adjust the input voltage.

Table 3.2.1 (b) list the input power specification. Use a power source with sufficient capacity so that the system will not malfunction due to a voltage drop even at a time of peak load.

Table 3.2.1 (b) AC power voltage specifications (200-V input type)

Model	$\beta iSV4$	$\beta iSV20$	$\beta iSV40$	$\beta iSV80$	$\beta iSV20/20$	$\beta iSV40/40$
Nominal voltage rating	200 to 240VAC -15%,+10%					
Power source frequency	50/60Hz ± 1 Hz					
Power source capacity (for the main circuit) [kVA]	0.2	2.8	4.7	6.5	2.7	4.8
Power source capacity (for the control circuit) [kVA]	22				24	

(2) 1-axis βi SV series (400-V type)

Table 3.2.2 (a) Action for the AC power (200-V input type)

Permissible voltage fluctuation width	Nominal voltage	Action
-15%+10%	3-phase 400 to 480 VAC	1-axis βi SV series (A06B-6131-H ^{***}) (<u>βiSV10HV, βiSV 20HV, βiSV 40HV</u>) Permitted.
-10%+10%	3-phase 380 to 480 VAC	1-axis βi SV series for 30i-B series CNC (A06B-6161-H ^{***}) (<u>βiSV10HV, βiSV 20HV, βiSV 40HV</u>) Permitted.
-15%+10%	1-phase 220 to 240VAC	Not permitted.
Other than the above		Not permitted.

Table 3.2.2 (b) list the input power specification. Use a power source with sufficient capacity so that the system will not malfunction due to a voltage drop even at a time of peak load.

Table 3.2.2 (b) AC power voltage specifications (200-V input type)

Series	1-axis βi SV series (A06B-6131-H ^{***})			1-axis βi SV series for 30i-B series CNC (A06B-6161-H ^{***})		
	βi SV10HV	βi SV20HV	βi SV40HV	βi SV10HV	βi SV20HV	βi SV40HV
Nominal voltage rating	400 to 480VAC -15%,+10%			380 to 480VAC -10%,+10%		
Power source frequency	50/60Hz \pm 1Hz					
Power source capacity (for the main circuit) [kVA]	1.6	2.5	6.2	1.9	3.9	6.2
Power source capacity (for the control circuit) [kVA]	22					

3.2.2 Connecting a Protective Ground

Check that a protective ground is connected correctly with reference to individual items in Chapter 6 "INSTALLATION" in the FANUC SERVO AMPLIFIER βi series Descriptions (B-65322EN).

3.2.3 Selecting the Ground Fault Interrupter That Matches the Leakage Current

Check that a ground fault breaker is selected correctly with reference to individual items in Chapter 6 "INSTALLATION" in the FANUC SERVO AMPLIFIER βi series Descriptions (B-65322EN).

3.3 INITIALIZING PARAMETERS (SWITCHES AND DUMMY CONNECTORS)

(1) β iSV4, β iSV20

- When no regenerative resistor is used
Connect connector CXA20 by using a dummy connector.
See FANUC SERVO AMPLIFIER β i series DESCRIPTIONS B-65322EN.

(2) β iSV40, β iSV80

- Switch (SW) setting
The regenerative resistor alarm level is set. The setting condition varies depending on the regenerative resistor used (the built-in regenerative resistor or separate regenerative resistor). Perform the setting properly.

⚠ WARNING

Incorrect setting can damage the regenerative resistor.

See FANUC SERVO AMPLIFIER β i series DESCRIPTIONS B-65322EN.

- When the built-in regenerative resistor is used
Connect connector CXA20 by using a dummy connector.
Connect connector CZ6 by using a dummy connector.
See FANUC SERVO AMPLIFIER β i series DESCRIPTIONS B-65322EN.

(3) β iSV20/20, β iSV40/40

- Switch (SW) setting
The regenerative resistor alarm level is set. The setting condition varies depending on the regenerative resistor used (when the regenerative resistor is not used or a separate regenerative resistor is used). Perform the setting properly.

⚠ WARNING

Incorrect setting can damage the regenerative resistor.

See FANUC SERVO AMPLIFIER β i series DESCRIPTIONS B-65322EN.

- When the built-in regenerative resistor is used
Connect connector CXA20 by using a dummy connector.
See FANUC SERVO AMPLIFIER β i series DESCRIPTIONS B-65322EN.

3.4 INITIALIZING SETTINGS

For the initialization of servo amplifiers or servo motors, refer to the following manual:

FANUC AC SERVO MOTOR α i series / FANUC AC SERVO MOTOR β i series/ FANUC LINEAR LiS series / FANUC BUILT-IN SERVO MOTOR DiS series Parameter Manual (B-65270EN)

4 CONFIRMATION OF THE OPERATION

4.1 SERVO AMPLIFIER MODULE

4.1.1 Check Procedure

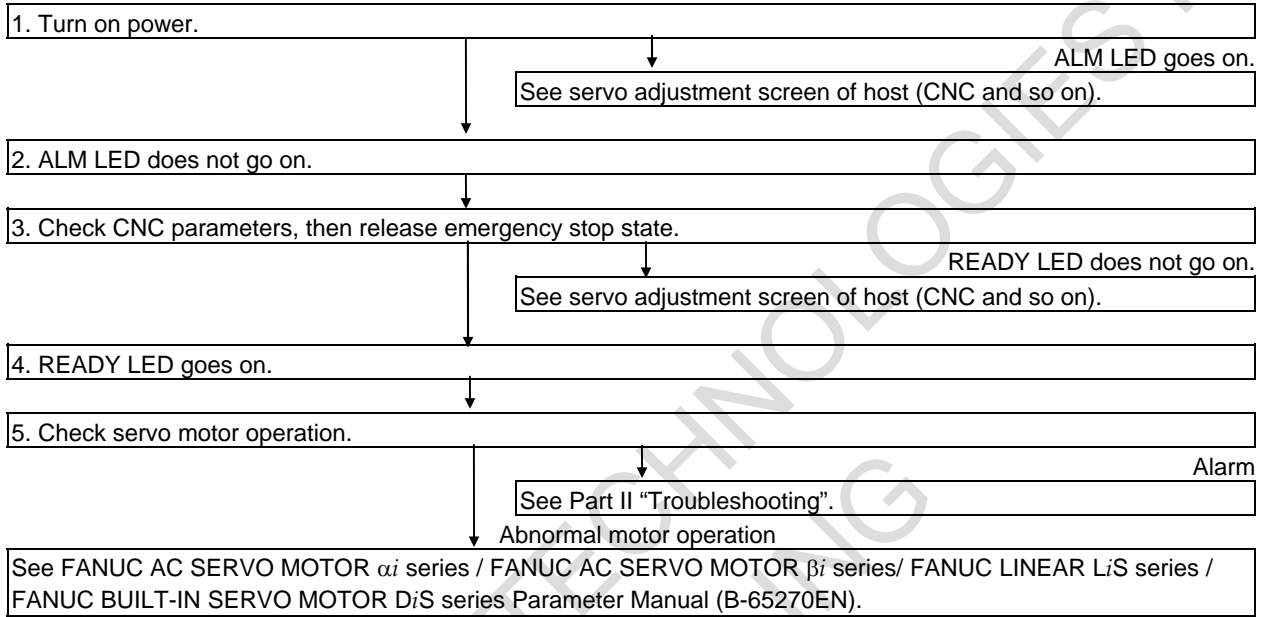

(1) β iSV4, β iSV20

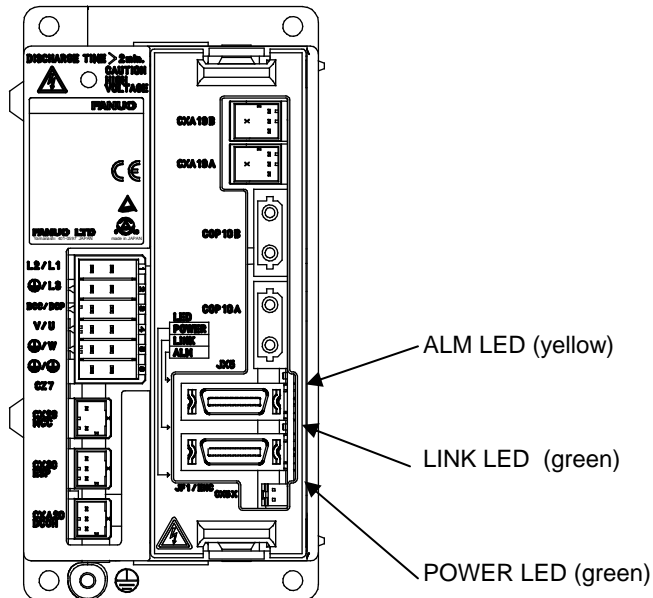

(2) β iSV40, β iSV80, β iSV10HV, β iSV20HV, β iSV40HV

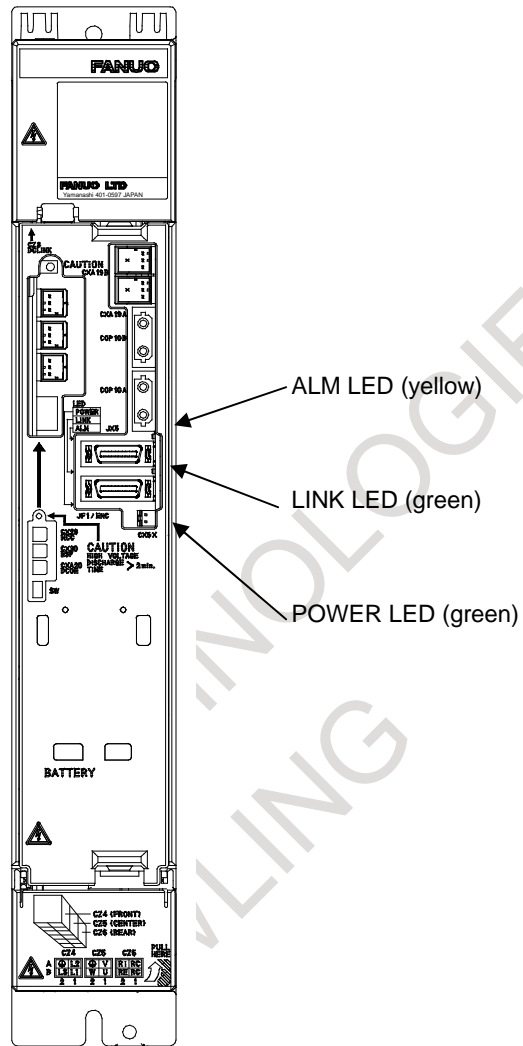

(3) β iSV20/20, β iSV40/40

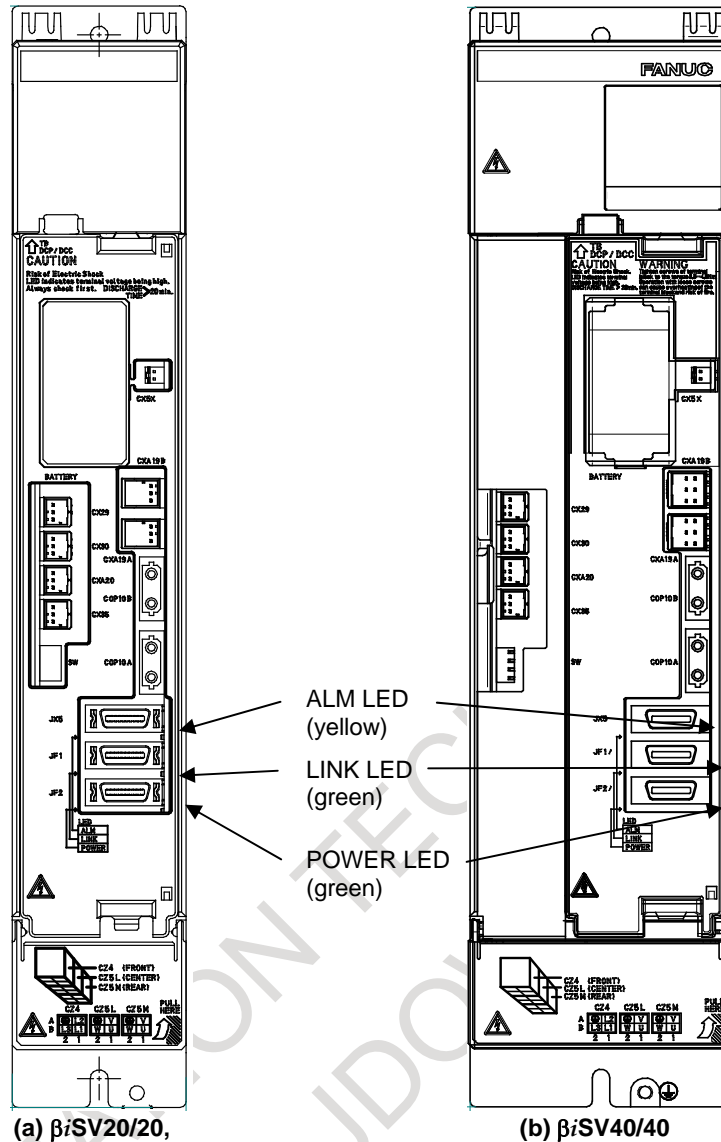

4.1.2 VRDY-OFF Alarm Indicated on the CNC Screen

When the VRDY-OFF alarm is indicated on the CNC, check the items listed below. In addition, VRDY-OFF can occur also for reasons other than listed below. If the following items turn out to have not caused VRDY-OFF, check diagnosis information No. 358 (V ready-off information) on the diagnosis screen and report it to FANUC.

- (1) Emergency stop signal (ESP)
Has the emergency stop signal (connector: CX30) applied to the β iSV been released? Alternatively, is the signal connected correctly?
- (2) MCON signal
Hasn't setting up the axis detach function disabled the transmission of the ready command signal MCON from the CNC to the β iSV?
- (3) β iSV control printed-circuit board
The β iSV control printed-circuit board may be poorly installed or faulty. Be sure to push the faceplate as far as it will go. If the problem persists, replace the control printed-circuit board.

Checking diagnosis information (DGN) No. 358 makes it possible to analyze the cause of the VRDY-OFF alarm.

* For Series 16i /18i /21i/0i/PMi, this function is supported in servo software Series 90B0/D(04) and subsequent editions.

Diagnosis **358**

V ready-off information

Convert the displayed value to binary form, and check bits 5 to 14 of the resulting binary number.

When the servo amplifier starts working, these bits become 1 sequentially, starting at bit 5. When the servo amplifier has started normally, all of bits 5 to 14 become 1.

Check bits 5 to 14 sequentially, starting at the lowest-order bit. The first lowest bit that is not 0 corresponds to the processing that caused the V ready-off alarm.

#15	#14	#13	#12	#11	#10	#9	#8
	SRDY	DRDY	INTL	RLY	CRDY	MCOFF	MCONA
#7	#6	#5	#4	#3	#2	#1	#0
MCONS	*ESP	HRDY					

#06(*ESP) : Emergency stop signal

#07,#08,#09 : MCON signal (CNC → amplifier → converter)

#10(CRDY) : Converter preparation completed signal

#11(RLY) : Relay signal (DB relay energized)

#12(INTL) : Interlock signal (DB relay de-energized)

#13(DRDY) : Amplifier preparation completed signal

The following table lists the values of diagnosis information No.358 and the major failure causes. Do not detach or attach any connector while the power is on.

Values of diagnosis information No. 358	Description of failures	Check items
417	Emergency stop has not been released.	(1) Check that an emergency stop signal applied to CX30 of the common power supply has been released. (2) Check that there is no anomaly on the connection for communication between the amplifiers or the related cable. (3) Replace the servo amplifier.
993	The β iSV ready signal (CRDY) is not output.	(1) Check that there is no problem with the connection for communication (CXA2A/B) between the amplifiers or the related cable. (2) Check that the input power is supplied. (3) Check that the operation coil of the magnetic contactor is supplied with power and that there is no problem with the connection of CX29 of β iSV. (4) Replace the servo amplifier.
4065	The interlock signal is not input.	Replace the servo amplifier.
225	-	Replace the servo amplifier.
481	-	Replace the servo amplifier.
2017	-	Replace the servo amplifier.
8161	-	Replace the servo amplifier.
97	-	Check that the axis detach function has not been set.

4.1.3 Method for Observing Motor Current

This subsection explains how to observe the current that flows through the servo motor.

(1) Method of using the SERVO GUIDE

Refer to online help for explanations about how to connect to and use the servo adjustment tool "SERVO GUIDE" and applicable CNC systems.

- Setting

Select an axis to be subjected to measurement in graph window channel setting. Also select IR and IS under Kind. Under Coef (conversion coefficient), set the maximum allowable current (Ap) for the amplifier in use.

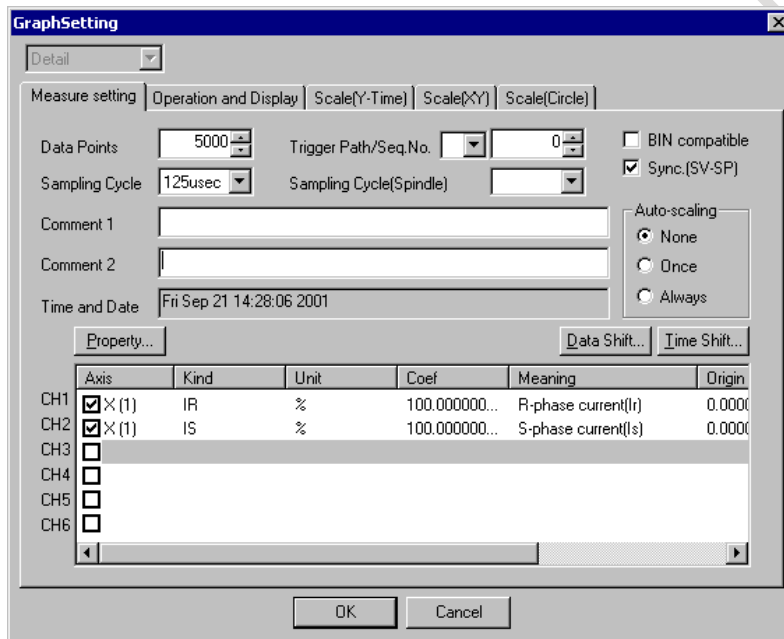

NOTE

- 1 In servo software series except for series 9096, the minimum motor current sampling cycle depends on the current control cycle.
- 2 Servo software series 9096 supports setting of a motor current sampling period of 1 ms only.

- Display

Select the XTYT mode from the graph window mode (M) menu to display waveforms.

(2) Method of using the servo check board

For details on how to connect and use the servo check board, refer to “FANUC AC SERVO MOTOR α i series / FANUC AC SERVO MOTOR β i series/ FANUC LINEAR LiS series / FANUC BUILT-IN SERVO MOTOR DiS series Parameter Manual (B-65270EN).”

For Series 30i/31i/32i and Series 0i-MODEL C, D, use the SERVO GUIDE because the servo check board cannot be connected and used.

- Required units

- Servo check board
A06B-6057-H630
- Oscilloscope

- Settings**· CNC setting**

Parameter setting for servo software series 90B0

Output channel	Data number 5		Data number 6	
FS15i	No.1726	No.1774	No.1775	No.1776
FS16i/18i/21i/0i/PMi	No.2115	No.2151	No.2152	No.2153
Measurement axis/ current phase	IR		IS	
L-axis ^(Note 1)	370	0	402	0
M-axis ^(Note 1)	2418	0	2450	0

Parameter setting for servo software series 9096

Output channel	Data number 5	Data number 6
FS16i/18i/21i/0i/PMi	No.2115	No.2115
Measurement axis/ current phase	IR	IS
L-axis ^(Note 1)	370	402
M-axis ^(Note 1)	1010	1042

When series 9096 is used, if no axis is paired with the measurement axis ^(Note 2), IR and IS cannot be observed simultaneously.

NOTE

- 1 The L-axis is an axis identified with an odd number set in parameter No. 1023. The M-axis is an axis identified with an even number set in parameter No. 1023.
- 2 The axis specified as 2n-1 in parameter No. 1023 and the axis specified as 2n will be in a pair.

Setting the output period of motor current data (for the 90B0 series only)

Output period	Parameter No. 1746 / Bit 7 of parameter No. 2206
Velocity loop period	0 (default)
Current loop period	1 ^(Note 3)

NOTE

- 3 If the current loop period is set up as the motor current data output period, selecting data number **0**, **1**, **2**, or **4** disables the output of signals (such as a velocity command) to channels. To observe the motor current and other signals (such as a velocity command), specify the output period as 1 ms.
- 4 For the servo software series 9096, the output period of the motor current is only 1 msec. The current loop period cannot be used for output.

· Setting up the check board

- Set the AXIS digit of the LED display with an axis number from **1** to **8** specified in parameter No. 1023.
- Set the DATA digit of the LED display with a data number from **5** to **6**.

- Method for observing the motor current

The voltage corresponding to the motor current is output to a channel for which $\boxed{5}$ or $\boxed{6}$ is set as the data number on the servo check board.

The waveform of the motor current can be observed by measuring the voltage mentioned above with an oscilloscope.

The following table lists the relationships between the observed voltage and the motor current.

Maximum amplifier current	β iSV type	Motor current/ observed voltage [A/V]
4A	β iSV4	1
10A	β iSV10HV	2.5
20A	β iSV20, β iSV20/20 β iSV20HV	5
40A	β iSV40, β iSV40/40 β iSV40HV	10
80A	β iSV80	20

For the β iSV20, for example, the motor current is 5A (actual value rather than effective value) if the observed voltage is 1V.

II. TROUBLESHOOTING FOR βiSV

JR AUTOMATION TECHNOLOGIES INC*
JDOWLING

JR AUTOMATION TECHNOLOGIES INC*
JDOWLING

1 OVERVIEW

This part describes the troubleshooting procedure. Read the section related to your current trouble to locate it and take an appropriate action.

First, check the alarm number (indicated by the CNC) and the β iSV indication in Chapter 2 to find the cause.

Then, take an appropriate action according to the corresponding description in Chapter 3.

JR AUTOMATION TECHNOLOGIES INC*
JDOWLING

2 ALARM NUMBERS AND BRIEF DESCRIPTIONS

2.1 FOR Series 30i/31i/32i/35i-B, Power Motion i-A

2.1.1 Servo Alarm

Alarm No.	Description	Reference item
SV0361	Pulsecoder phase error (built-in)	3.2.7 (1)
SV0364	Soft phase alarm (built-in)	3.2.7 (1)
SV0365	LED error (built-in)	3.2.7 (1)
SV0366	Pulse error (built-in)	3.2.7 (1)
SV0367	Count error (built-in)	3.2.7 (1)
SV0368	Serial data error (built-in)	3.2.7 (3)
SV0369	Data transfer error (built-in)	3.2.7 (3)
SV0380	LED error (separate)	3.2.7 (2)
SV0381	Pulsecoder phase error (separate)	3.2.7 (2)
SV0382	Count error (separate)	3.2.7 (2)
SV0383	Pulse error (separate)	3.2.7 (2)
SV0384	Soft phase alarm (separate)	3.2.7 (2)
SV0385	Serial data error (separate)	3.2.7 (3)
SV0386	Data transfer error (separate)	3.2.7 (3)
SV0387	Sensor error (separate)	3.2.7 (2)
SV0417	Invalid parameter	3.2.6
SV0421	Excessive semi-full error	3.2.8
SV0430	Servo motor overheat	3.2.5
SV0432	PS: control undervoltage	3.1.4
SV0433	PS: DC link undervoltage	3.1.1
SV0436	Soft thermal (OVC)	3.2.3
SV0438	SV : current alarm	3.1.9
SV0439	PS : DC link overvoltage	3.1.2
SV0440	PS : Excessive regenerative power 2	3.1.3
SV0441	Current offset error	3.2.8
SV0444	SV: internal cooling fan stopped	3.1.5
SV0445	Soft disconnection alarm	3.2.4
SV0447	Hard disconnection alarm (separate)	3.2.4
SV0448	Feedback mismatch alarm	3.2.8
SV0449	SV: IPM alarm	3.1.7
SV0453	Soft disconnection alarm (α Pulsecoder)	3.2.4
SV0601	SV: cooling fan stopped of the radiator	3.1.6
SV0603	SV: IPM alarm (OH)	3.1.8

2.2 FOR Series 30i/31i/32i-A

2.2.1 Servo Alarm

Alarm No.	Description	Reference item
SV0361	Pulsecoder phase error (built-in)	3.2.7 (1)
SV0364	Soft phase alarm (built-in)	3.2.7 (1)

Alarm No.	Description	Reference item
SV0365	LED error (built-in)	3.2.7 (1)
SV0366	Pulse error (built-in)	3.2.7 (1)
SV0367	Count error (built-in)	3.2.7 (1)
SV0368	Serial data error (built-in)	3.2.7 (3)
SV0369	Data transfer error (built-in)	3.2.7 (3)
SV0380	LED error (separate)	3.2.7 (2)
SV0381	Pulsecoder phase error (separate)	3.2.7 (2)
SV0382	Count error (separate)	3.2.7 (2)
SV0383	Pulse error (separate)	3.2.7 (2)
SV0384	Soft phase alarm (separate)	3.2.7 (2)
SV0385	Serial data error (separate)	3.2.7 (3)
SV0386	Data transfer error (separate)	3.2.7 (3)
SV0387	Sensor error (separate)	3.2.7 (2)
SV0417	Invalid parameter	3.2.6
SV0421	Excessive semi-full error	3.2.8
SV0430	Servo motor overheat	3.2.5
SV0432	Converter: control power supply undervoltage	3.1.4
SV0433	Converter: DC link undervoltage	3.1.1
SV0436	Soft thermal (OVC)	3.2.3
SV0438	Inverter: motor current alarm	3.1.9
SV0439	Converter: DC link overvoltage	3.1.2
SV0440	Converter: Excessive deceleration power	3.1.3
SV0441	Current offset error	3.2.8
SV0444	Inverter: internal cooling fan stopped	3.1.5
SV0445	Soft disconnection alarm	3.2.4
SV0447	Hard disconnection alarm (separate)	3.2.4
SV0448	Feedback mismatch alarm	3.2.8
SV0449	Inverter: IPM alarm	3.1.7
SV0453	Soft disconnection alarm (α Pulsecoder)	3.2.4
SV0601	Inverter: cooling fan stopped of the radiator	3.1.6
SV0603	Inverter: IPM alarm (OH)	3.1.8

2.3 FOR Series 0i/0i Mate-D

2.3.1 Servo Alarm

Alarm No.	Description	Reference item
SV0361	Pulsecoder phase error (built-in)	3.2.7 (1)
SV0364	Soft phase alarm (built-in)	3.2.7 (1)
SV0365	LED error (built-in)	3.2.7 (1)
SV0366	Pulse error (built-in)	3.2.7 (1)
SV0367	Count error (built-in)	3.2.7 (1)
SV0368	Serial data error (built-in)	3.2.7 (3)
SV0369	Data transfer error (built-in)	3.2.7 (3)
SV0380	LED error (separate)	3.2.7 (2)
SV0381	Pulsecoder phase error (separate)	3.2.7 (2)
SV0382	Count error (separate)	3.2.7 (2)
SV0383	Pulse error (separate)	3.2.7 (2)
SV0384	Soft phase alarm (separate)	3.2.7 (2)
SV0385	Serial data error (separate)	3.2.7 (3)
SV0386	Data transfer error (separate)	3.2.7 (3)
SV0387	Sensor error (separate)	3.2.7 (2)
SV0417	Invalid parameter	3.2.6

Alarm No.	Description	Reference item
SV0421	Excessive semi-full error	3.2.8
SV0430	Servo motor overheat	3.2.5
SV0432	Converter: control power supply undervoltage	3.1.4
SV0433	Converter: DC link undervoltage	3.1.1
SV0436	Soft thermal (OVC)	3.2.3
SV0438	Inverter: motor current alarm	3.1.9
SV0439	Converter: DC link overvoltage	3.1.2
SV0440	Converter: Excessive deceleration power	3.1.3
SV0441	Current offset error	3.2.8
SV0444	Inverter: internal cooling fan stopped	3.1.5
SV0445	Soft disconnection alarm	3.2.4
SV0447	Hard disconnection alarm (separate)	3.2.4
SV0448	Feedback mismatch alarm	3.2.8
SV0449	Inverter: IPM alarm	3.1.7
SV0453	Soft disconnection alarm (α Pulsecoder)	3.2.4
SV0601	Inverter: cooling fan stopped of the radiator	3.1.6
SV0603	Inverter: IPM alarm (OH)	3.1.8

2.4 FOR Series 15i

2.4.1 Servo Alarm

Alarm No.	Description	Reference item
SV0027	Invalid digital servo parameter setting	3.2.6
SV0361	Pulsecoder phase error (built-in)	3.2.7 (1)
SV0364	Soft phase alarm (built-in)	3.2.7 (1)
SV0365	LED error (built-in)	3.2.7 (1)
SV0366	Pulse error (built-in)	3.2.7 (1)
SV0367	Count error (built-in)	3.2.7 (1)
SV0368	Serial data error (built-in)	3.2.7 (3)
SV0369	Data transfer error (built-in)	3.2.7 (3)
SV0380	LED error (separate)	3.2.7 (2)
SV0381	Pulsecoder phase error (separate)	3.2.7 (2)
SV0382	Count error (separate)	3.2.7 (2)
SV0383	Pulse error (separate)	3.2.7 (2)
SV0384	Soft phase alarm (separate)	3.2.7 (2)
SV0385	Serial data error (separate)	3.2.7 (3)
SV0386	Data transfer error (separate)	3.2.7 (3)
SV0387	Sensor error (separate)	3.2.7 (2)
SV0421	Excessive semi-full error	3.2.8
SV0430	Servo motor overheat	3.2.5
SV0432	Converter: control power supply undervoltage	3.1.4
SV0433	Converter: DC link undervoltage	3.1.1
SV0436	Soft thermal (OVC)	3.2.3
SV0438	Inverter: motor current alarm	3.1.9
SV0439	Converter: DC link overvoltage	3.1.2
SV0440	Converter: Excessive deceleration power	3.1.3
SV0441	Current offset error	3.2.8
SV0444	Inverter: internal cooling fan stopped	3.1.5
SV0445	Soft disconnection alarm	3.2.4
SV0447	Hard disconnection alarm (separate)	3.2.4
SV0448	Feedback mismatch alarm	3.2.8
SV0449	Inverter: IPM alarm	3.1.7

Alarm No.	Description	Reference item
SV0601	Inverter: cooling fan stopped of the radiator	3.1.6
SV0603	Inverter: IPM alarm (OH)	3.1.8

2.5 FOR Series 16i, 18i, 20i, 21i, 0i, AND Power Mate i

2.5.1 Servo Alarm

Alarm No.	Description	Reference item
361	Pulsecoder phase error (built-in)	3.2.7 (1)
364	Soft phase alarm (built-in)	3.2.7 (1)
365	LED error (built-in)	3.2.7 (1)
366	Pulse error (built-in)	3.2.7 (1)
367	Count error (built-in)	3.2.7 (1)
368	Serial data error (built-in)	3.2.7 (3)
369	Data transfer error (built-in)	3.2.7 (3)
380	LED error (separate)	3.2.7 (2)
381	Pulsecoder phase error (separate)	3.2.7 (2)
382	Count error (separate)	3.2.7 (2)
383	Pulse error (separate)	3.2.7 (2)
384	Soft phase alarm (separate)	3.2.7 (2)
385	Serial data error (separate)	3.2.7 (3)
386	Data transfer error (separate)	3.2.7 (3)
387	Sensor error (separate)	3.2.7 (2)
417	Invalid parameter	3.2.6
421	Excessive semi-full error	3.2.8
430	Servo motor overheat	3.2.5
432	Converter: control power supply undervoltage	3.1.4
433	Converter: DC link undervoltage	3.1.1
436	Soft thermal (OVC)	3.2.3
438	Inverter: motor current alarm	3.1.9
439	Converter: DC link overvoltage	3.1.2
440	Converter: Excessive deceleration power	3.1.3
441	Current offset error	3.2.8
444	Inverter: internal cooling fan stopped	3.1.5
445	Soft disconnection alarm	3.2.4
447	Hard disconnection alarm (separate)	3.2.4
448	Feedback mismatch alarm	3.2.8
449	Inverter: IPM alarm	3.1.7
453	Soft disconnection alarm (α Pulsecoder)	3.2.4
601	Inverter: cooling fan stopped of the radiator	3.1.6
603	Inverter: IPM alarm (OH)	3.1.8

3 TROUBLESHOOTING AND ACTION

3.1 SERVO AMPLIFIER MODULE

The following table lists alarms related to the servo amplifier module.

See this table and the CNC alarm code indicated in Chapter 2, "ALARM NUMBERS AND BRIEF DESCRIPTIONS".

Alarm	LED display	Major cause	Reference item
Converter: DC link undervoltage PS: DC link undervoltage	ON	Voltage drop at the DC link in the main circuit	3.1.1
Converter: DC link overvoltage PS: DC link overvoltage	ON	Voltage rise at the DC link in the main circuit	3.1.2
Converter: excessive deceleration power PS: Excessive regenerative power 2	ON	- Too large regenerative discharge amount - Abnormal regenerative discharge circuit	3.1.3
Converter: control power supply undervoltage PS: control power supply undervoltage	ON	- Drop in external control power supply (24 V) - Connector/cable (CXA19A, CXA19B) defective - β iSV failure	3.1.4
Inverter: internal cooling fan stopped SV: internal cooling fan stopped	ON	- Fan not running. - Fan motor connector or cable defective - β iSV failure	3.1.5
Inverter: cooling fan stopped of the radiator SV: cooling fan stopped of the radiator	ON	- Fan not running. - Fan motor connector or cable defective - β iSV failure	3.1.6
Inverter: IPM alarm SV: IPM alarm	ON	- Short-circuit between power lead phases or ground fault in them - Short-circuit between motor winding phases or ground fault in them - β iSV failure	3.1.7
Inverter: IPM alarm (OH) SV: IPM alarm (OH)	ON	- The motor is being used under a harsh condition. - The ambient temperature is high. - β iSV failure	3.1.8
Inverter: motor current alarm SV: current alarm	ON	- Short-circuit between power lead phases or ground fault in them - Short-circuit between motor winding phases or ground fault in them - Incorrect motor ID setting - β iSV or motor failure	3.1.9
FSSB communication error	ON	- Connector or cable failure - β iSV or CNC failure	3.1.10

3.1.1 Converter: DC Link Undervoltage

- (1) Meaning
The voltage at the DC link of the converter is low.
- (2) Cause and troubleshooting
 - (a) A small power dip has occurred.
→ Check the power supply.
 - (b) Low input power supply voltage

- Check the power supply specification.
- (c) Insert the βiSV face plate (control printed-circuit board) securely.
 - (d) Replace the βiSV .

3.1.2 Converter: DC Link Overvoltage

- (1) Meaning
In the main circuit, the voltage at the DC link is abnormally high.
- (2) Cause and troubleshooting
 - (a) $\beta iSV4$ and $\beta iSV20$
Use a regenerative resistor.
 - (b) Excessive regenerated power
Increase the acceleration/deceleration time constant. If this alarm occurs less frequently, the regeneration capacity is not sufficient. Set the acceleration/deceleration time constant to such a level that does not cause any alarm.
 - (c) Insert the βiSV face plate (control printed-circuit board) securely.
 - (d) Replace the βiSV .
 - (e) Check that the regenerative resistor is broken or poorly connected.

3.1.3 Converter: Excessive Deceleration Power

- (1) Meaning
The converter deceleration power is too large.
- (2) Cause and troubleshooting
For $\beta iSV4$ and $\beta iSV20$
 - When a separate regenerative resistor is not used
 - (a) Connect CXA20 by using a dummy connector.
 - (b) Insert the βiSV face plate (control printed-circuit board) securely.
 - (c) Replace the βiSV .
 - When a separate regenerative resistor is used
 - (a) Check the resistance at both ends of connector CXA20 on the regenerative resistor side to confirm that the resistance is 0Ω .
 - (b) The average regenerative power may be high. Decrease the frequency of acceleration/deceleration, or review the resistor specification.
 - (c) Insert the βiSV face plate (control printed-circuit board) securely.
 - (d) Replace the βiSV .
- For $\beta iSV40$ and $\beta iSV80$
 - When the built-in regenerative resistor is used
 - (a) Connect CXA20 and CZ6 by using a dummy connector.
 - (b) The average regenerative power may be high. Decrease the frequency of acceleration/deceleration, or review the resistor specification.
 - (c) Insert the βiSV face plate (control printed-circuit board) securely.
 - (d) Replace the βiSV .
 - When a separate regenerative resistor is used
 - (a) Check the resistance at both ends of connector CXA20 on the regenerative resistor side to confirm that the resistance is 0Ω .
 - (b) The average regenerative power may be high. Decrease the frequency of acceleration/deceleration, or review the resistor specification.
 - (c) Insert the βiSV face plate (control printed-circuit board) securely.
 - (d) Replace the βiSV .

3.1.4 Converter: Control Power Supply Undervoltage

- (1) Meaning
The external control power supply (24 VDC) voltage is low.
- (2) Cause and troubleshooting
 - (a) Check the voltage level of the external power supply (24 VDC). (Normal voltage: 21.6 V or higher)
 - (b) Check the connector and cable (CXA19A, CXA19B).
 - (c) Replace the β iSV.

3.1.5 Inverter: Internal Cooling Fan Stopped

- (1) Meaning
Inverter: internal cooling fan stopped
- (2) Cause and troubleshooting
 - (a) Check whether there is any foreign material in the fan.
 - (b) Be sure to push the faceplate (control printed-circuit board) as far as it will go.
 - (c) Check that the fan connector is attached correctly.
 - (d) Replace the fan.
 - (e) Replace the β iSV.

3.1.6 Inverter: Cooling Fan Stopped of the Radiator

- (1) Meaning
Inverter: cooling fan stopped of the radiator
- (2) Cause and troubleshooting
 - (a) Check whether there is any foreign material in the fan.
 - (b) Be sure to push the faceplate (control printed-circuit board) as far as it will go.
 - (c) Check that the fan connector is attached correctly.
 - (d) Replace the fan.
 - (e) Replace the β iSV.

3.1.7 Inverter: IPM Alarm

- (1) Meaning
Inverter: IPM alarm
- (2) Cause and troubleshooting
 - (a) Be sure to push the faceplate (control printed-circuit board) as far as it will go.
 - (b) Disconnect the motor power leads from the β iSV, and release the β iSV from an emergency stop condition.
 - <1> If no IPM alarm condition has occurred
→ Go to (c).
 - <2> If an IPM alarm condition has occurred
→ Replace the β iSV.
 - (c) Disconnect the motor power leads from the β iSV, and check the insulation between PE and the motor power lead U, V, or W.
 - <1> If the insulation is deteriorated
→ Go to (d).
 - <2> If the insulation is normal
→ Replace the β iSV.

- (d) Disconnect the motor from its power leads, and check whether the insulation of the motor or power leads is deteriorated.
 - <1> If the insulation of the motor is deteriorated
 - Replace the motor.
 - <2> If the insulation of any power lead is deteriorated
 - Replace the power lead.

3.1.8 Inverter: IPM Alarm (OH)

- (1) Meaning
Inverter: IPM alarm (OH)
- (2) Cause and troubleshooting
 - (a) Be sure to push the faceplate (control printed-circuit board) as far as it will go.
 - (b) Check that the heat sink cooling fan is running.
 - (c) Check that the motor is being used at or below its continuous rating.
 - (d) Check that the cooling capacity of the cabinet is sufficient (inspect the fans and filters).
 - (e) Check that the ambient temperature is not too high.
 - (f) Replace the β iSV.

3.1.9 Inverter: Motor Current Alarm

- (1) Meaning
Inverter: DC link current alarm
- (2) Cause and troubleshooting
 - (a) Checking the servo parameters
Referring to "FANUC AC SERVO MOTOR α i series / FANUC AC SERVO MOTOR β i series / FANUC LINEAR LiS series / FANUC BUILT-IN SERVO MOTOR DiS series Parameter Manual (B-65270EN)," check whether the following parameters have default values.

Series 15i	No.1809	No.1852	No.1853
Other than Series 15i	No.2004	No.2040	No.2041

- Alternatively, if an abnormal motor current alarm condition occurs only on rapid acceleration/deceleration, it is likely that the motor is being used under too harsh a condition. Increase the acceleration/deceleration time constant, and see what will occur.
- (b) Be sure to push the faceplate (control printed-circuit board) as far as it will go.
 - (c) Disconnect the motor power leads from the β iSV, and release the β iSV from an emergency stop condition.
 - <1> If no abnormal motor current occurs
 - Go to (d).
 - <2> If an abnormal motor current occurs
 - Replace the β iSV.
 - (d) Disconnect the motor power leads from the β iSV, and check the insulation between PE and the motor power lead U, V, or W.
 - <1> If the insulation is deteriorated
 - Go to (e).
 - <2> If the insulation is normal
 - Replace the β iSV.
 - (e) Disconnect the motor from its power leads, and check whether the insulation of the motor or power leads is deteriorated.
 - <1> If the insulation of the motor is deteriorated
 - Replace the motor.
 - <2> If the insulation of any power lead is deteriorated
 - Replace the power lead.

3.1.10 FSSB Communication Error

- (1) Meaning
Inverter: FSSB communication error
- (2) Cause and troubleshooting
 - (a) Replace the optical cable (COP10A) of the β iSV that is nearest to the CNC among the amplifiers on which the ALM LED is lit (in Fig. 3.1.10, the cable between UNIT2 and UNIT3).
 - (b) Replace the β iSV that is the second nearest to the CNC among the amplifiers on which the ALM LED is lit (in Fig. 3.1.10, UNIT3).
 - (c) Replace the β iSV that is nearest to the CNC among the amplifiers on which the ALM LED is lit (in Fig. 3.1.10, UNIT2).
 - (d) Replace the servo card in the CNC.

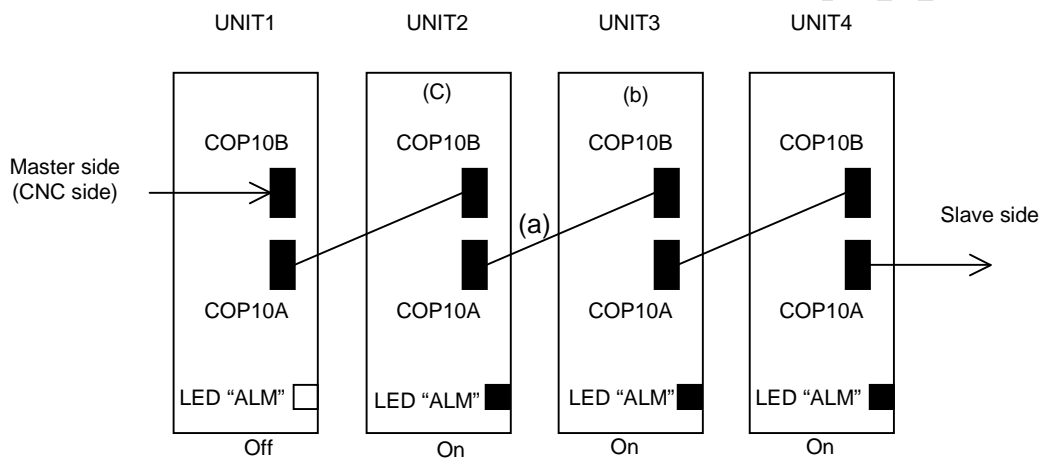

Fig. 3.1.10

3.2 SERVO SOFTWARE

If a servo alarm is issued, an alarm message is output, and details of the alarm are also displayed on the servo adjustment screen or the diagnosis screen. Using the alarm identification table given in this section, determine the alarm, and take a proper action.

3.2.1 Servo Adjustment Screen

The following procedure can be used to display the servo adjustment screen.
(The DPL/MDI of the Power Mate has no servo adjustment screen.)

- **Series 15i**

SYSTEM → [CHAPTER] → [SERVO] → [▷] → [SERVO ALARM]

- **Series 30i, 31i, 32i, 16i, 18i, 21i, 0i**

SYSTEM → [SYSTEM] → [▷] → [SV-PRM] → [SV-TUN]

If the servo setting screen does not appear, specify the following parameter, then switch the CNC off and on again.

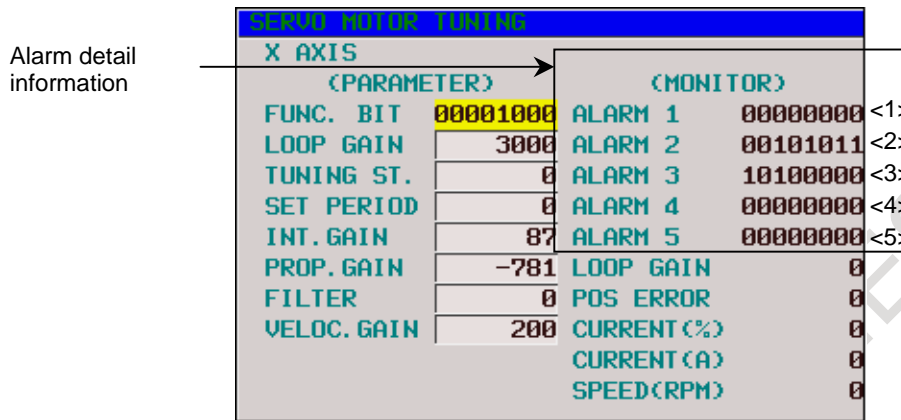
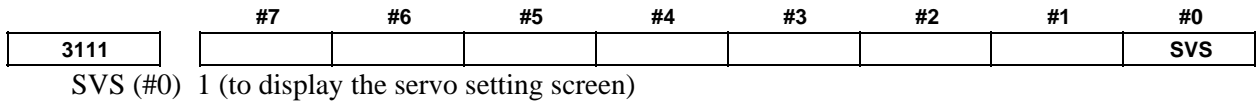

Fig. 3.2.1(a) Servo adjustment screen

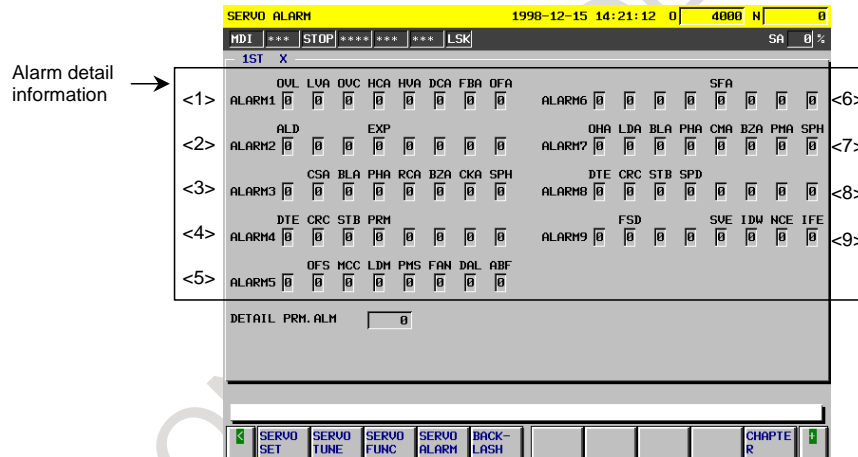

Fig. 3.2.1(b) Series 15i servo alarm screen

The table below indicates the names of the alarm bits.

Table 3.2.1 List of alarm bit names

	#7	#6	#5	#4	#3	#2	#1	#0
<1> Alarm 1	OVL	LVA	OVC	HCA	HVA	DCA	FBA	OFA
<2> Alarm 2	ALD			EXP				
<3> Alarm 3		CSA	BLA	PHA	RCA	BZA	CKA	SPH
<4> Alarm 4	DTE	CRC	STB	PRM				
<5> Alarm 5		OFS	MCC	LDM	PMS	FAN	DAL	ABF
<6> Alarm 6					SFA			
<7> Alarm 7	OHA	LDA	BLA	PHA	CMA	BZA	PMA	SPH
<8> Alarm 8	DTE	CRC	STB	SPD				
<9> Alarm 9		FSD			SVE	IDW	NCE	IFE

NOTE

The empty fields do not represent alarm codes.

3.2.2 Diagnosis Screen

The alarm items of the servo adjustment screen correspond to the diagnosis screen numbers indicated in the table below.

Table 3.2.2 Correspondence between the servo adjustment screen and diagnosis screen

Alarm No.	Series15i	Series16i,18i,21i,0i
<1> Alarm 1	No 3014+20(X-1)	No 200
<2> Alarm 2	3015+20(X-1)	201
<3> Alarm 3	3016+20(X-1)	202
<4> Alarm 4	3017+20(X-1)	203
<5> Alarm 5	_____	204
<6> Alarm 6	_____	_____
<7> Alarm 7	_____	205
<8> Alarm 8	_____	206
<9> Alarm 9	_____	_____

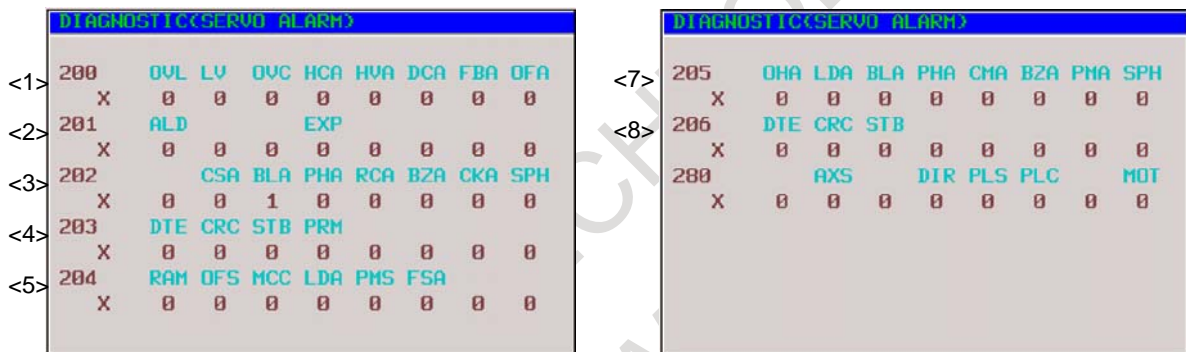

Fig. 3.2.2 Diagnosis screen

3.2.3 Overload Alarm (Soft Thermal, OVC)

(Alarm identification method)

	#7	#6	#5	#4	#3	#2	#1	#0
<1> Alarm 1	OVL	LVA	OVC	HCA	HVA	DCA	FBA	OFA

(Action)

- (1) Make sure that the motor is not vibrating.
 - ⇒ If a motor vibrates, the current flowing in it becomes more than necessary, resulting in an alarm.
- (2) Make sure that the power lead to the motor is connected correctly.
 - ⇒ If the connection is incorrect, an abnormal current flows in the motor, resulting in an alarm.
- (3) Make sure that the following parameters are set correctly.
 - ⇒ An overload alarm is issued based on the result of calculation of these parameters. Be sure to set them to the standard values. For details of the standard values, refer to the FANUC AC SERVO MOTOR α i series / FANUC AC SERVO MOTOR β i series/ FANUC LINEAR LiS series / FANUC BUILT-IN SERVO MOTOR DiS series Parameter Manual (B-65270EN).

No. 1877 (FS15i)	Overload protection coefficient (OVC1)
No. 2062 (FS16i)	

No. 1878 (FS15i)	Overload protection coefficient (OVC2)
No. 2063 (FS16i)	

No. 1893 (FS15i)	Overload protection coefficient (OVCLMT)
No. 2065 (FS16i)	
No. 1785 (FS15i)	Overload protection coefficient (OVC21)
No. 2162 (FS16i)	
No. 1786 (FS15i)	Overload protection coefficient (OVC22)
No. 2163 (FS16i)	
No. 1787 (FS15i)	Overload protection coefficient (OVCLMT2)
No. 2164 (FS16i)	

- (4) Attach the check board to connector JX5 to measure the waveform of the actual current (IR and IS) of the servo amplifier module. (This check pin board differs from that for the α series.)
Run the motor and measure its actual currents (IR and IS). Then compare the measurement results with the overload duty curve shown in "FANUC AC SERVO MOTOR β i series Descriptions (B-65302EN)," and see whether the machine load is too heavy compared with the motor capacity. If the actual current is high on acceleration/deceleration, it is likely that the time constant is too small.

3.2.4 Feedback Disconnected Alarm

(Alarm identification method)

	#7	#6	#5	#4	#3	#2	#1	#0
<1> Alarm 1	OVL	LVA	OVC	HCA	HVA	DCA	FBA	OFA
<2> Alarm 2	ALD			EXP				
<6> Alarm 6					SFA			

FBA	ALD	EXP	SFA	Alarm description	Action
1	1	1	0	Hard disconnection (separate phase A/B)	1
1	0	0	0	Soft disconnection (closed loop)	2
1	0	0	1	Soft disconnection (α i Pulsecoder)	3

(Action)

Action 1:

This alarm is issued when a separate phase A/B scale is used. Check if the phase A/B detector is connected correctly.

Action 2:

This alarm is issued when the position feedback pulse variation is small relative to the velocity feedback pulse variation. This means that this alarm is not issued when a semi-full is used. Check if the separate detector outputs position feedback pulses correctly. If position feedback pulses are output correctly, it is considered that the motor alone is rotating in the reverse direction at the start of machine operation because of a large backlash between the motor position and scale position.

	#7	#6	#5	#4	#3	#2	#1	#0
No. 1808 (FS15i)							TGAL	
No. 2003 (FS16i)								

TGAL (#1) 1: Uses the parameter for the soft disconnection alarm detection level.

No. 1892 (FS15i)	Soft disconnection alarm level
No. 2064 (FS16i)	

Standard setting 4: Alarm issued for a 1/8 rotation of the motor.
Increase this value.

Action 3:

This alarm is issued when synchronization between the absolute position data sent from the built-in Pulsecoder and phase data is lost. Turn off the power to the CNC, then detach the Pulsecoder cable then attach it again. If this alarm is still issued, replace the Pulsecoder.

3.2.5 Overheat Alarm

(Alarm identification method)

	#7	#6	#5	#4	#3	#2	#1	#0
<1> Alarm 1	OVL	LVA	OVC	HCA	HVA	DCA	FBA	OFA
<2> Alarm 2	ALD			EXP				

OVL	ALD	EXP	Alarm description	Action
1	1	0	Motor overheat	1
1	0	0	Amplifier overheat	1

(Action)

Action 1:

If this alarm is issued after a long-time of continuous operation, it is considered that the motor and amplifier are overheated. Stop operation for a while, then make a check. If this alarm is still issued after the power is off for about 10 minutes then is turned on again, the thermostat is considered to be faulty. If this alarm is issued intermittently, increase the time constant or increase stop time in the program to suppress the rise in temperature.

3.2.6 Invalid Servo Parameter Setting Alarm

The invalid servo parameter setting alarm is issued when a setting out of the specifiable range is specified, or an overflow has occurred in an internal calculation. When an invalid parameter is detected on the servo side, alarm 4#4(PRM)=1 results.

(Alarm identification method)

	#7	#6	#5	#4	#3	#2	#1	#0
<4> Alarm 4	DTE	CRC	STB	PRM				

For details and action required when the invalid servo parameter setting alarm is issued on the servo side, refer to the FANUC AC SERVO MOTOR α i series / FANUC AC SERVO MOTOR β i series/ FANUC LINEAR LiS series / FANUC BUILT-IN SERVO MOTOR DiS series Parameter Manual (B-65270EN).

(Reference information)

Method of checking details of an invalid parameter detected on the servo side

(For Series 15i)

A number is indicated in the item "Details of invalid parameter" on the servo alarm screen (Fig. 3.2.1(b)).

(For Series 30i, 16i, 18i, 21i, 0i, and Power Mate i)

A number is indicated in No. 352 of the diagnosis screen.

3.2.7 Alarms Related to Pulsecoder and Separate Serial Detector

(Bits for alarm identification)

	#7	#6	#5	#4	#3	#2	#1	#0
<1> Alarm 1	OVL	LVA	OVC	HCA	HVA	DCA	FBA	OFA
<2> Alarm 2	ALD			EXP				
<3> Alarm 3		CSA	BLA	PHA	RCA	BZA	CKA	SPH
<4> Alarm 4	DTE	CRC	STB	PRM				
<5> Alarm 5		OFS	MCC	LDM	PMS	FAN	DAL	ABF
<6> Alarm 6					SFA			
<7> Alarm 7	OHA	LDA	BLA	PHA	CMA	BZA	PMA	SPH
<8> Alarm 8	DTE	CRC	STB	SPD				
<9> Alarm 9		FSD			SVE	IDW	NCE	IFE

(1) For a built-in Pulsecoder

An alarm is determined from the bits of alarms 1, 2, 3, and 5. The table below indicates the meaning of each bit.

Alarm 3							Alarm 5		1	Alarm 2			Alarm description	Action
CSA	BLA	PHA	RCA	BZA	CKA	SPH	LDM	PMA	FBA	ALD	EXP			
				1		1							Soft phase alarm	2
													Zero battery voltage	1
			1						1	1	0		Count error alarm	2
		1											Phase alarm	2
	1												Battery voltage decrease (Caution)	1
								1					Pulse error alarm	
							1						LED error alarm	

⚠ CAUTION

An alarm for which no action number is given is considered to be caused by a Pulsecoder failure. Replace the Pulsecoder.

(2) For a separate serial detector

An alarm is determined from the bits of alarm 7. The table below indicates the meaning of each bit.

Alarm 7								Alarm description	Action
OHA	LDA	BLA	PHA	CMA	BZA	PMA	SPH		
							1	Soft phase alarm	2
							1	Pulse error alarm	
					1			Zero battery voltage	1
				1				Count error alarm	2
			1					Phase alarm	2
		1						Battery voltage decrease (Caution)	1
	1							LED error alarm	
1								Separate detector alarm	3

⚠ CAUTION

An alarm for which no action number is given is considered to be caused by a detector failure. Replace the detector.

(Action)

Action 1: Battery-related alarms

Check if a battery is connected. When the power is turned on for the first time after a battery is connected, the zero battery voltage alarm is issued. In such a case, turn off the power, then turn on the power again. If the alarm is still issued, check the battery voltage. If the battery voltage decrease alarm is issued, check the voltage, and replace the battery as required.

Action 2: Alarms that may be issued for noise

If an alarm is issued intermittently or after emergency stop cancellation, noise is probably the cause. So, provide noise protection. If the same alarm is still issued after noise protection is provided, replace the detector.

Action 3: Alarm condition detected by the separate detector

If the separate detector detects an alarm condition, contact the manufacturer of the detector for information on troubleshooting.

(3) Alarms related to serial communication

An alarm is determined from the bits of alarms 4 and 8.

Alarm 4			Alarm 8			Alarm description
DTE	CRC	STB	DTE	CRC	STB	
1						Serial Pulsecoder communication alarm
	1					
		1				Separate serial Pulsecoder communication alarm
			1			
				1		
					1	

Action:

Serial communication is not performed correctly. Check if the cable is connected correctly and is not broken. If CRC or STB is issued, noise may be the cause. So, provide noise protection. If CRC or STB is always issued after the power is turned on, the Pulsecoder or amplifier control board or the pulse module may be faulty.

3.2.8 Other Alarms

(Alarm identification method)

	#7	#6	#5	#4	#3	#2	#1	#0
<5> Alarm 5		OFS	MCC	LDM	PMS	FAN	DAL	ABF

OFS	DAL	ABF	Alarm description	Action
		1	Feedback mismatch alarm	1
	1		Excessive semi-full error alarm	2
1			Current offset error alarm	3

(Action)

Action 1:

This alarm is issued when the move direction of the position detector is opposite to the move direction of the speed detector. Check the rotation direction of the separate detector. If the rotation direction of the separate detector is opposite to the rotation direction of the motor, take the following action:

For a phase A/B detector: Reverse the connections of A and XA.

For a serial detector: Reverse the setting of the signal direction of the separate detector.

In the Series 90B0/G(07) and subsequent editions, the following settings enable signal directions in the A/B phase detector to be inverted.

	#7	#6	#5	#4	#3	#2	#1	#0
No. 1960 (FS15i)								RVRSE
No. 2018 (FS16i)								

- RVRSE (#0) Reverses the signal direction of the separate detector.
- 0: Does not reverse the signal direction of the separate detector.
 - 1: Reverses the signal direction of the separate detector.

If a large distortion exists between the motor and separate detector, this alarm may be issued in the case of abrupt acceleration/deceleration. In such a case, modify the detection level.

	#7	#6	#5	#4	#3	#2	#1	#0
No. 1741 (FS15i)							RNLV	
No. 2201 (FS16i)								

- RNLV (#1) Modifies the feedback mismatch alarm detection level.
- 1: Detected with 1000 min^{-1} or more
 - 0: Detected with 600 min^{-1} or more

Action 2:

This alarm is issued when the difference between the motor position and separate detector position exceeds the excessive semi-full error level. Check if the conversion efficient for dual position feedback is set correctly. If the conversion efficient is set correctly, increase the alarm level. If this alarm is still issued after the level is modified, check the connection direction of the scale.

No. 1971 (FS15i)	Dual position feedback conversion coefficient (numerator)
No. 2078 (FS16i)	

No. 1972 (FS15i)	Dual position feedback conversion coefficient (denominator)
No. 2079 (FS16i)	

$$\text{Conversion coefficient} = \frac{\left(\begin{array}{l} \text{Number of feedback pulses per motor} \\ \text{revolution (detection unit)} \end{array} \right)}{1,000,000}$$

No. 1729 (FS15i)	Dual position feedback semi-full error level
No. 2118 (FS16i)	

[Setting] Detection unit. When 0 is set, no detection is made.

Action 3:

The current offset value of the current detector (equivalent to the current value in the emergency stop state) is abnormally high. If this alarm is still issued after the power is turned off then back on, the current detector is faulty. For the β i series, replace the amplifier.

4 REPLACING SERVO AMPLIFIER COMPONENTS

This chapter describes how to replace a fan motor, absolute Pulsecoder battery, fuses, and printed-circuit board.

⚠ WARNING

Because the Servo Amplifier uses a large-capacitance electrolytic capacitor internally, the Servo Amplifier remains charged for a while even after the power is turned off. Before touching the Servo Amplifier for maintenance or other purposes, ensure your safety by measuring the residual voltage in the DC link with a tester and confirming that the charge indication LED (red) is off.

4.1 REPLACEMENT OF A FAN MOTOR

4.1.1 For the Internal Cooling Fan Motor: β iSV4, β iSV20

- <1> Pull out the fan connector upward.
- <2> Push the front of the fan unit to disengage the lug.
- <3> Disengage the rear of the fan unit.
- <4> Lift the fan unit in a slant direction.

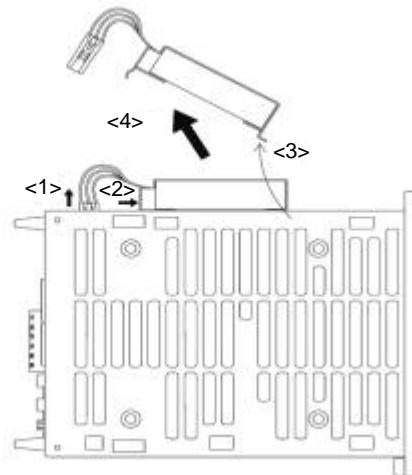

When replacing the fan motor, pay attention to its orientation and the cable drawing position.

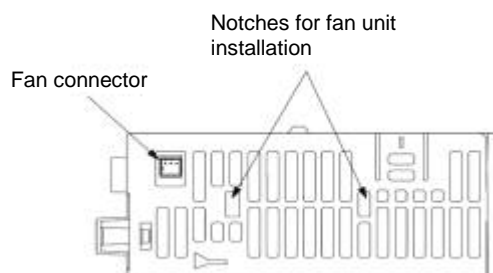
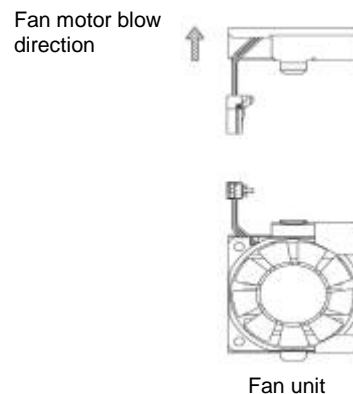

4.1.2 For the Internal Cooling Fan Motor: β iSV40, β iSV80, β iSV10HV, β iSV20HV, β iSV40HV

- 1 Hold the two handles of the fan unit and pull up them in the direction (the upward direction of the figure) of the arrow.

Holding the two lugs on the fan unit, lift the fan unit in the direction of the arrow (toward the top in the figure).

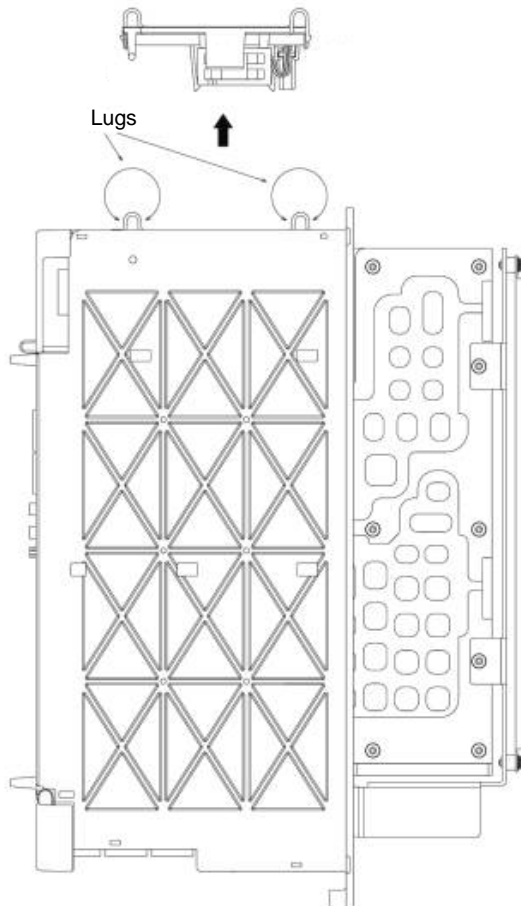

When replacing the fan motor, pay attention to its orientation and the orientation of the connector.

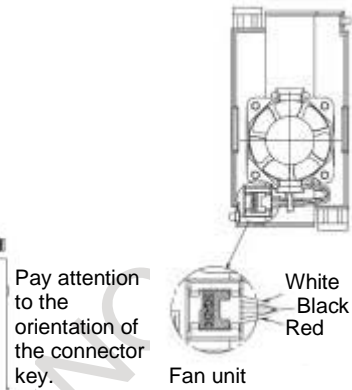

4.1.3 For the Internal Cooling Fan Motor: β iSV20/20, β iSV40/40

- 1 Hold the two handles of the fan unit and pull up them in the direction (the upward direction of the figure) of the arrow.

Holding the two lugs on the fan unit, lift the fan unit in the direction of the arrow (toward the top in the figure).

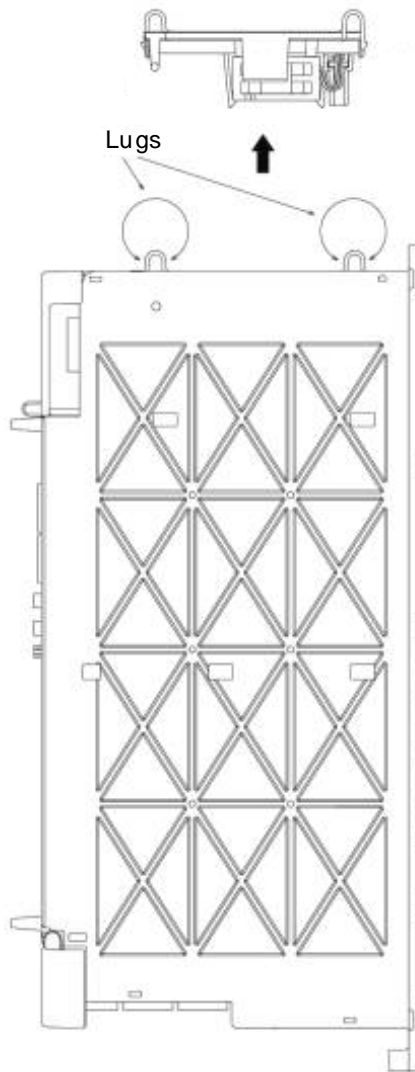

When replacing the fan motor, pay attention to its orientation and the orientation of the connector.

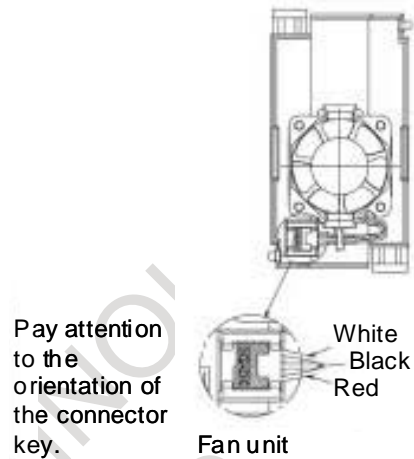

4.1.4 For the Radiator Cooling Fan Motor: β iSV40, β iSV80, β iSV10HV, β iSV20HV, β iSV40HV

- 1 Holding the two lugs on the fan unit, lift the fan unit in the direction of the arrow (upward in the figure).

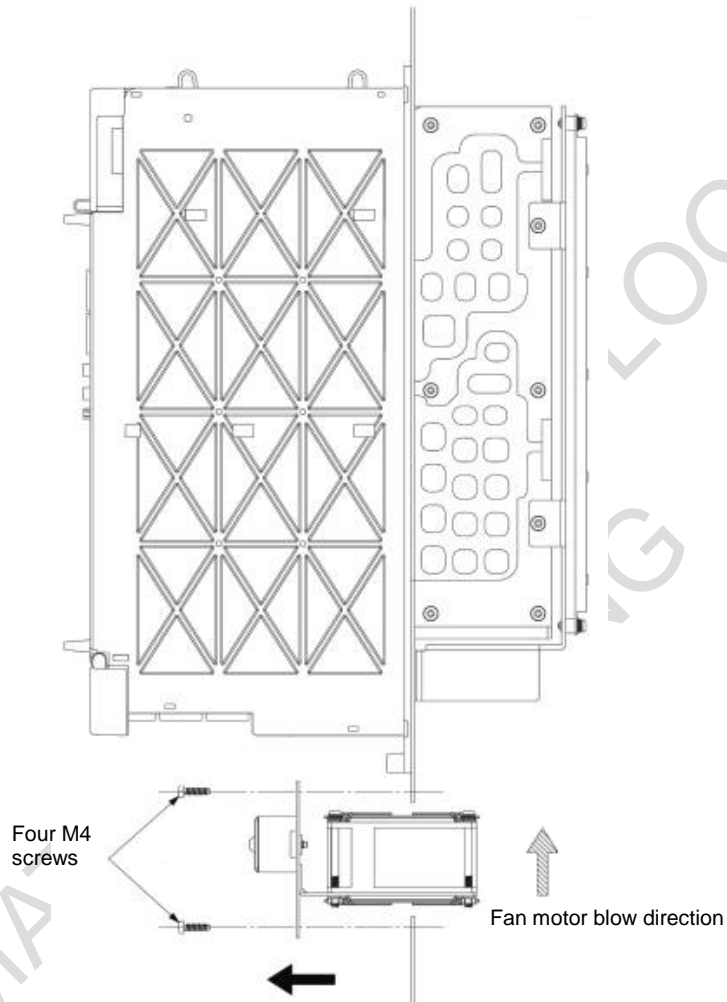

4.2 REPLACING BATTERY FOR ABSOLUTE PULSECODERS

4.2.1 Overview

- When the voltage of the batteries for absolute Pulsecoders becomes low, alarm 307 or 306 occurs, with the following indication in the CNC state display at the bottom of the CNC screen.
Alarm 307 (alarm indicating the voltage of the battery becomes low) :
The indication "APC" blinks in reversed display.
Alarm 306 (battery zero alarm) :
The indication "ALM" blinks in reversed display.
- When alarm 307 (alarm indicating the voltage of the battery becomes low) occurs, replace the battery as soon as possible. In general, the battery should be replaced within one or two weeks, however, this depends on the number of Pulsecoders used.
- When alarm 306 (battery zero alarm) occurs, Pulsecoders are reset to the initial state, in which absolute positions are not held. Alarm 300 (reference position return request alarm) also occurs, indicating that reference position return is required.
- In general, replace the batteries periodically within the service life listed below.
 - A06B-6050-K061 or D-size alkaline dry cells (LR20): Two years (for each six-axis configuration)
 - A06B-6093-K001 : One years (for each three-axis configuration)
 - A06B-6114-K504 : One year (for each three-axis configuration)

NOTE

The above values indicate the estimated service life of batteries used with FANUC absolute Pulsecoders. The actual battery service life depends on the machine configuration based on, for example, detector types. For details, contact the machine tool builder.

4.2.2 Replacing Batteries

To prevent absolute position information in absolute Pulsecoders from being lost, turn on the machine power before replacing the battery. The replacement procedure is described below.

- <1> Ensure that the power to the servo amplifier is turned on.
- <2> Ensure that the machine is in the emergency stop state (the motor is inactive).
- <3> Ensure that the DC link charge LED of the servo amplifier is off.
- <4> Detach the old batteries and attach new ones.

The replacement of the batteries in a separate battery case and the replacement of the battery built into the servo amplifier are described below in detail.

⚠ WARNING

- 1 The absolute Pulsecoder of each of the β i series servo motors (β iS0.4 to β iS40, β iSc, and β iF) has a built-in backup capacitor. Therefore, even when the power to the servo amplifier is off and the batteries are replaced, reference position return is not required if the replacement completes within less than 10 minutes. Turn the power on and replace the batteries if the replacement will take 10 minutes or more.
- 2 To prevent electric shock, be careful not to touch metal parts in the power magnetics cabinet when replacing the batteries.

⚠ WARNING

- 3 Because the servo amplifier uses a large-capacitance electrolytic capacitor internally, the servo amplifier remains charged for a while even after the power is turned off. Before touching the servo amplifier for maintenance or other purposes, ensure your safety by measuring the residual voltage in the DC link with a tester and confirming that the charge indication LED (red) is off.
- 4 Be sure to replace the batteries with specified ones. Pay attention to the battery polarity. If a wrong type of battery is used or a battery is installed with incorrect polarity, the battery may overheat, blow out, or catch fire, or the absolute position information in the absolute Pulsecoders may be lost.
- 5 Ensure that the battery connector is inserted in the correct position.

4.2.3 Replacing the Batteries in a Separate Battery Case

Use the following procedure to replace the batteries in the battery case.

- <1> Loosen the screws on the battery case and detach the cover.
- <2> Replace the batteries in the case (pay attention to the polarity).
- <3> Attach the cover to the battery case.

Battery case (with a cover)
A06B-6050-K060



Batteries
Four A06B-6050-K061 batteries or
D-size alkaline dry cells

⚠ CAUTION

- 1 Four D-size alkaline dry cells (LR20) that are commercially available can be used as batteries. A set of four A06B-6050-K061 batteries is optionally available from FANUC.
- 2 Replace all the four batteries with new ones. If old and new batteries are mixed, the absolute position information in the absolute Pulsecoders may be lost.

4.2.4 Replacing the Battery Built into the Servo Amplifier

Use the following procedure to replace the special lithium battery.

- <1> Detach the battery case.
- <2> Replace the special lithium battery.
- <3> Attach the battery case.

⚠ CAUTION

- 1 Purchase the battery from FANUC because it is not commercially available. It is therefore recommended that you have a backup battery.
- 2 When the built-in battery is used, do not connect BATL (B3) of connector CXA19B/CXA19A. Also, do not connect two or more batteries to the same BATL (B3) line. These connections are dangerous because battery output voltages may be short-circuited, causing the batteries to overheat.
- 3 Install the battery in the servo amplifier in a direction that allows slack in the cable. If the battery cable is under tension, a bad connection may occur.

4. REPLACING SERVO

⚠ CAUTION

- 4 If the +6 V pin and 0 V pin of CX5X are short-circuited, the battery may overheat, blow out, or catch fire, or the absolute position information in the absolute Pulsecoders may be lost.
- 5 When inserting the connector, align it to the connector pins.

(1) For β iSV4 and β iSV20

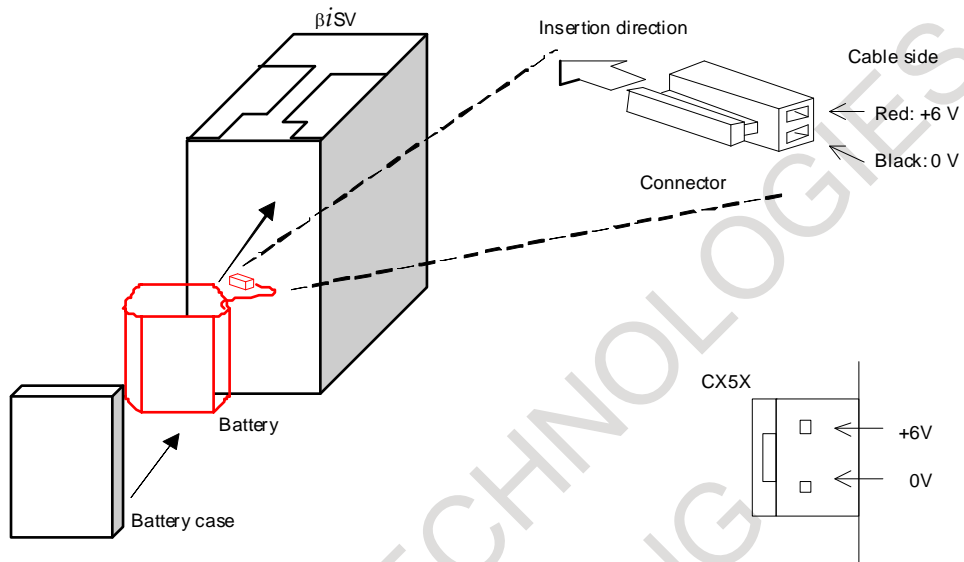

(2) For β iSV40, β iSV80, β iSV10HV, β iSV20HV, and β iSV40HV

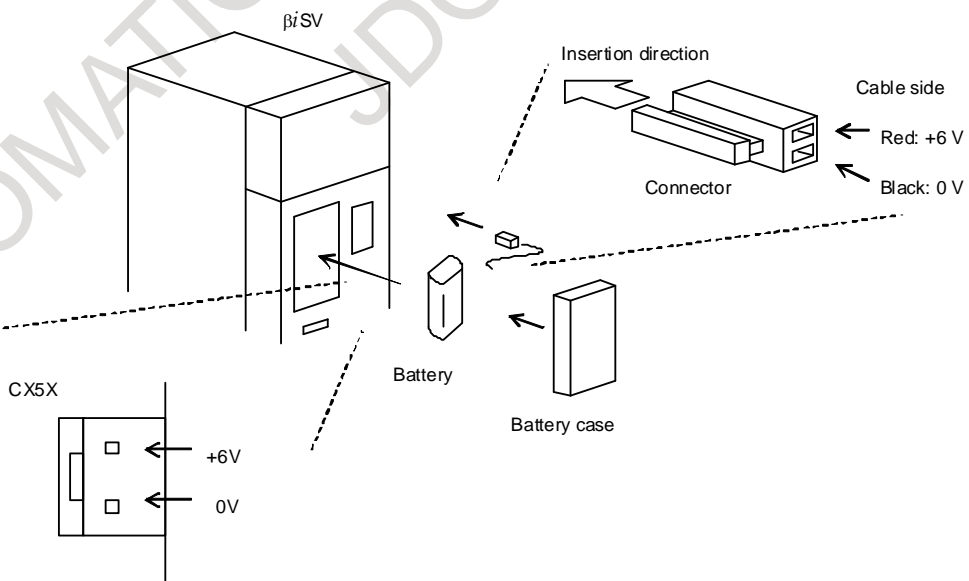

(3) For $\beta iSV20/20$ and $\beta iSV40/40$

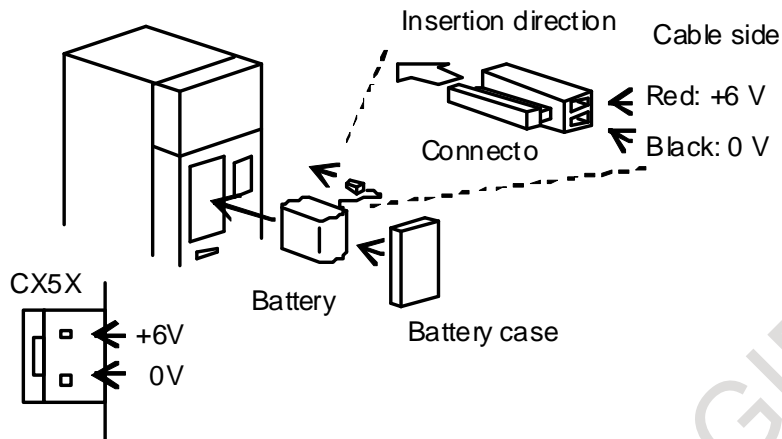

Used batteries

Old batteries should be disposed as "INDUSTRIAL WASTES" according to the regulations of the country or autonomy where your machine has been installed.

4.2.5 Notes on Replacing a Battery (Supplementary Explanation)

4.2.5.1 Battery connection modes

The battery for the absolute Pulsecoder can be connected using [Connection method 1] and [Connection method 2] explained below.

For details, refer to "Connecting the Battery" in the FANUC SERVO AMPLIFIER βi Series Descriptions (B-65322EN).

[Connection method 1] Method of supplying battery power from one battery to multiple βiSV amplifiers

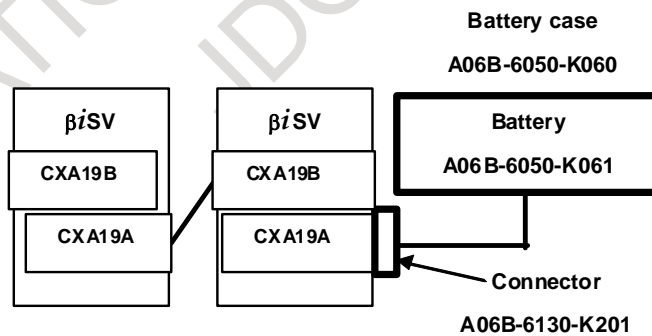

- If a low battery voltage or a battery voltage of 0 V is indicated by an APC (absolute Pulsecoder) alarm, replace the battery. If a battery voltage of 0 V is indicated, you need to make a zero point return.
- The absolute Pulsecoder of the βi series servo motor (βiS 0.4 to βiS 40, βiSc , and βiF) is incorporated with a backup capacitor as standard. This backup capacitor enables an absolute position detection to be continued for about 10 minutes. Therefore, no zero point return need be performed if the time during which servo amplifier power is kept off for battery replacement is within 10 minutes. The Pulsecoder of the β series servo motors and some of the βi series servo motors (βiS 0.2 to $\beta iS0.3$) does not include a backup capacitor. Be careful when replacing the battery for this Pulsecoder. See Subsection 4.2.5.2, "Connecting the battery for the β series motor" at the end of this section for details.
- The battery service life is about two years for the βi series servo motors (βiS 0.4 to βiS 40, βiSc , and βiF) if servo motors for six axes are connected. For the β series servo motors and some of the βi series servo motors (βiS 0.2 to $\beta iS0.3$), the battery service life is about one year.

4. REPLACING SERVO

AMPLIFIER COMPONENTS TROUBLESHOOTING FOR βiSV

B-65325EN/02

FANUC recommends that you replace the batteries periodically according to the battery service life.

- The battery unit consists of four R20 alkaline batteries. Commercial batteries can be used in the battery unit. The optional battery offered by FANUC is A06B-6050-K061.

⚠ WARNING

- 1 Do not connect more than one battery to the same BAT (B3) line. If the output voltage is different between the batteries, they may be short-circuited, resulting in the batteries becoming very hot.
- 2 Install the battery with correct polarity. If the battery is installed with incorrect polarity, it may overheat, blow out, or catch fire.

[Connection method 2] Method of building a built-in battery into each βiSV

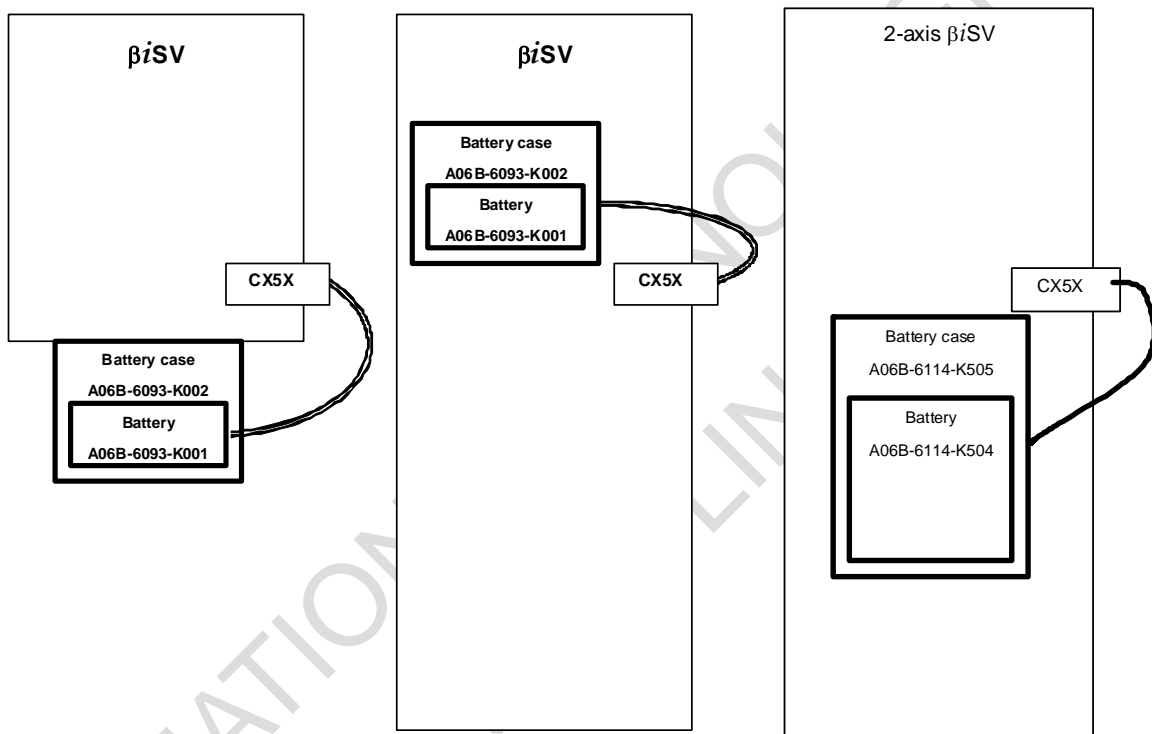

- If a low battery voltage or a battery voltage of 0 V is indicated by an APC (absolute Pulsecoder) alarm, replace the battery (A06B-6093-K001). If a battery voltage of 0 V is indicated, you need to make a zero point return.
- The absolute Pulsecoder of the βi series servo motor (βiS 0.4 to βiS 40, βiSc , and βiF) is incorporated with a backup capacitor as standard. This backup capacitor enables an absolute position detection to be continued for about 10 minutes. Therefore, no zero point return need be performed if the time during which servo amplifier power is kept off for battery replacement is within 10 minutes. The Pulsecoder of the β series servo motors and some of the βi series servo motors (βiS 0.2 to $\beta iS0.3$) does not include a backup capacitor. Be careful when replacing the battery for this Pulsecoder. See Subsection 4.2.5.2, “Connecting the battery for the β series motor” at the end of this section for details.
- The battery service life is about two years for the βi series servo motors (βiS 0.4 to βiS 40, βiSc , and βiF). For the β series servo motors and some of the βi series servo motors (βiS 0.2 to $\beta iS0.3$), the battery service life is about one year. FANUC recommends that you replace the batteries periodically according to the battery service life.
- The built-in batteries are not commercially available. They must be purchased from FANUC. So, FANUC recommends that you keep spares.

⚠ WARNING

- 1 When using the built-in batteries (A06B-6073-K001), do not connect them to the BAT (B3) of connector CXA19B/CXA19A.
The output voltages from different batteries may be short-circuited, resulting in the batteries becoming very hot.
- 2 Do not connect more than one battery to the same BAT (B3) line. If the output voltage is different between the batteries, they may be short-circuited, resulting in the batteries becoming very hot.
- 3 Install the battery with correct polarity. If the battery is installed with incorrect polarity, it may overheat, blow out, or catch fire.

4.2.5.2 Connecting the battery for the β series motor

The Pulsecoder for the β series servo motor and some models (β iS 0.2 to β iS 0.3) of the β i series servo motor is not incorporated with a backup capacitor as standard. To keep the absolute position information in the absolute Pulsecoder, you need to keep the control power turned on during battery replacement. Follow the procedure explained below.

[Replacing procedure for the battery]

1. Make sure that the power to the β iSV is on (the LED "POWER" on the front of the β iSV is on).
2. Make sure that the emergency stop button of the system has been pressed.
3. Make sure that the motor is not activated.
4. Make sure that the DC link charge LED of the β iSV is off.
5. Remove the old battery, and install a new battery.
6. This completes the replacement. You can turn off the power to the system.

⚠ WARNING

- 1 When replacing the battery, be careful not to touch bare metal parts in the panel. In particular, be careful not to touch any high-voltage circuits due to the electric shock hazard.
- 2 Before replacing the battery, check that the DC link charge confirmation LED on the front of the servo amplifier is off. Neglecting this check creates an electric shock hazard.
- 3 Install the battery with correct polarity. If the battery is installed with incorrect polarity, it may overheat, blow out, or catch fire.
- 4 Avoid a short-circuit between the +6 V and 0 V lines of a battery or cable. A short-circuit may lead to a hot battery, an explosion, or fire.

4.2.5.3 Notes on attaching connectors

If an excessive strain is applied to a connector when it is inserted or removed, a poor contact may result. When inserting and removing the battery connector, therefore, be careful not to apply an excessive wrenching force to it; just follow the instructions given in the following table.

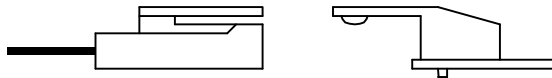

(1) Attaching connectors

<1>		Check the attachment position.
-----	---	--------------------------------

4. REPLACING SERVO

AMPLIFIER COMPONENTS TROUBLESHOOTING FOR β iSV

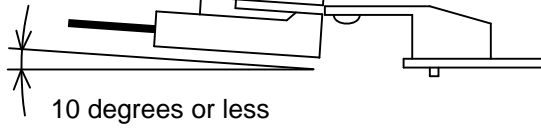
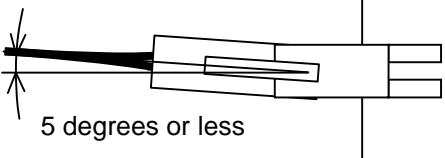
B-65325EN/02

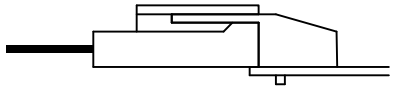
<2>	 <p>10 degrees or less</p>	<p>Plug the cable connector while raising it slightly.</p>
<5>	 <p>5 degrees or less</p>	<p>Here, the angle of the cable connector to the horizontal must be 5 degrees or less.</p>
<3>		<p>After passing the lock pin, insert the connector straight.</p>
<4>		<p>The attachment of the connector is completed.</p>

(2) Detaching the connector

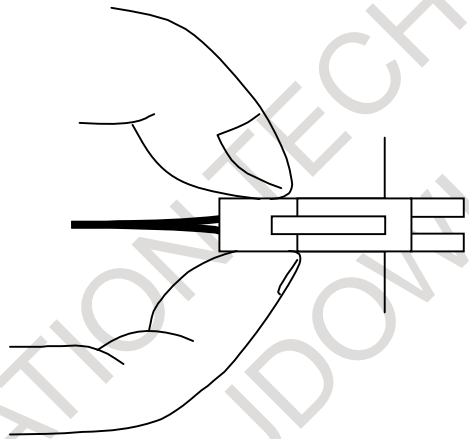
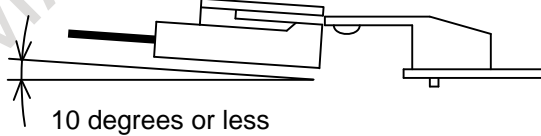
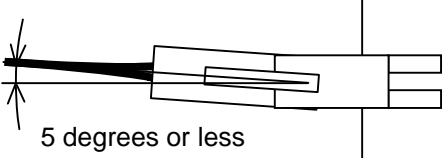
<1>		<p>Hold both the sides of the cable insulator and the cable, and pull them horizontally.</p>
<2>	 <p>10 degrees or less</p>	<p>Pull out the cable side while raising it slightly.</p>
<3>	 <p>5 degrees or less</p>	<p>Here, the angle of the cable to the horizontal must be 5 degrees or less.</p>

4.3 HOW TO REPLACE THE FUSES AND PRINTED CIRCUIT BOARDS

4.3.1 How to Replace the Fuses and Printed Circuit Boards

In the β i series, a printed-circuit board can be removed and inserted from the front of the servo amplifier.

- (1) For β iSV 4 and β iSV20

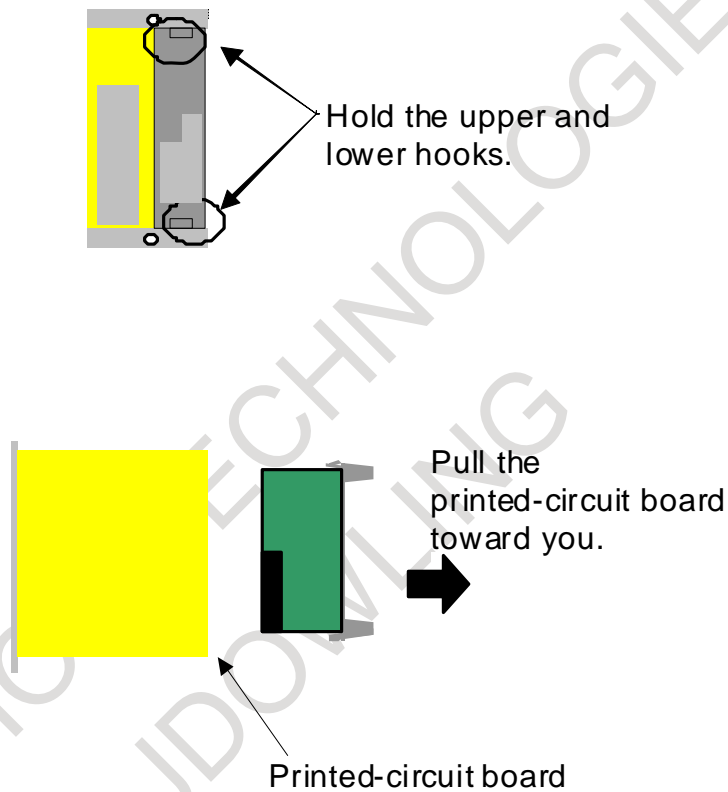

To insert the printed-circuit board, reverse the above procedure.

Ensure that the upper and lower hooks snap into the housing.

If the printed-circuit board is not inserted completely, the housing remains lifted. Pull out the printed-circuit board and insert it again.

4. REPLACING SERVO

AMPLIFIER COMPONENTS TROUBLESHOOTING FOR β iSV

B-65325EN/02

- (2) For β iSV40, β iSV 80, β iSV10HV, β iSV20HV, and β iSV40HV

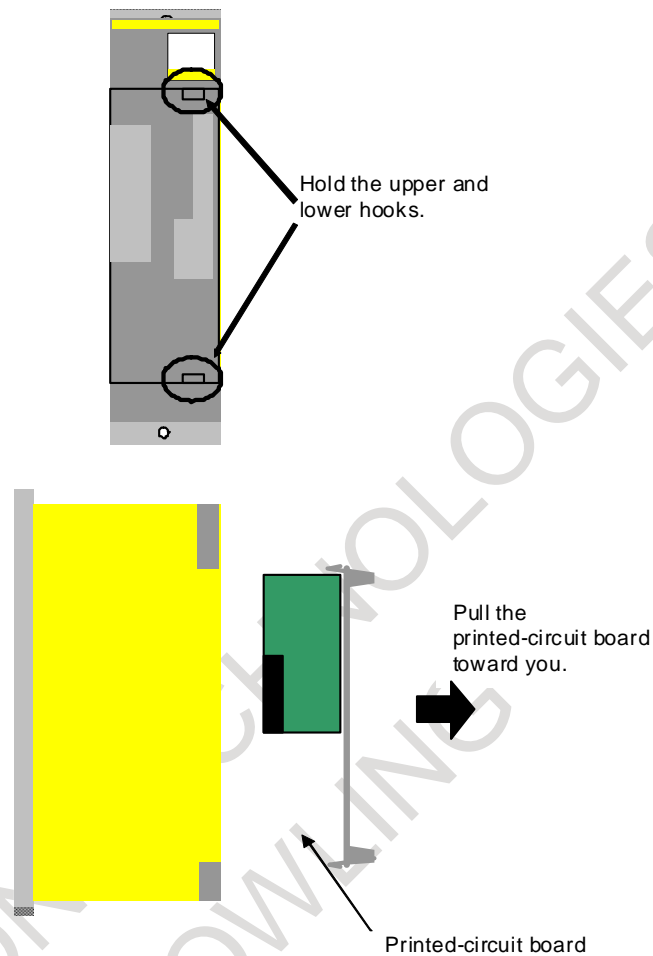

To insert the printed-circuit board, reverse the above procedure.

Ensure that the upper and lower hooks snap into the housing.

If the printed-circuit board is not inserted completely, the housing remains lifted. Pull out the printed-circuit board and insert it again.

(3) For β iSV20/20, and β iSV40/40

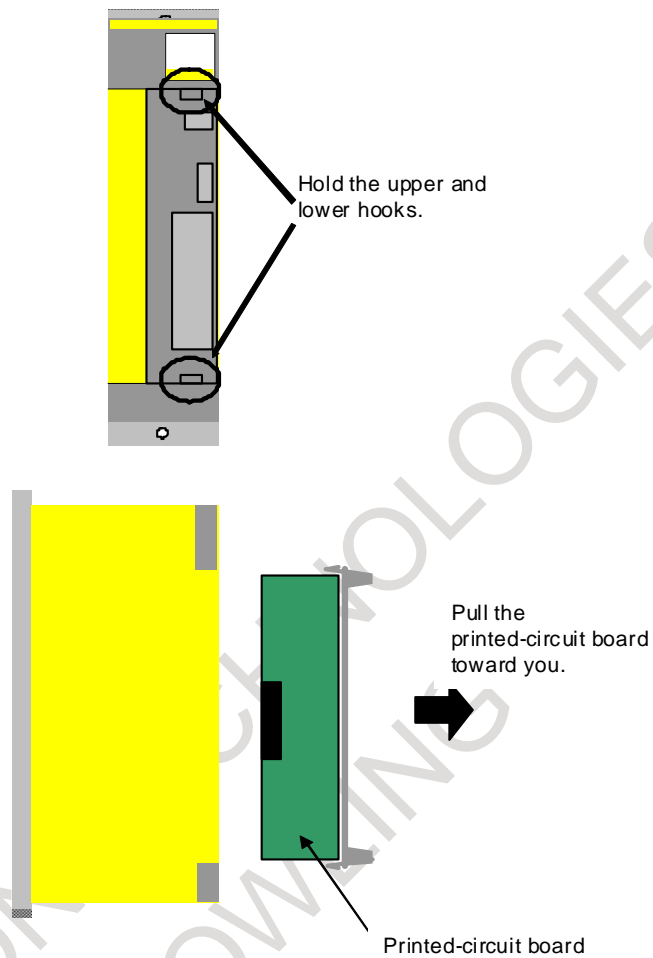

To insert the printed-circuit board, reverse the above procedure. Ensure that the upper and lower hooks snap into the housing. If the printed-circuit board is not inserted completely, the housing remains lifted. Pull out the printed-circuit board and insert it again.

4.3.2 Fuse Locations

There is one fuse on the β iSV printed-circuit board.

- (1) A20B-2101-0050, A20B-2101-0051, and A20B-2102-0081

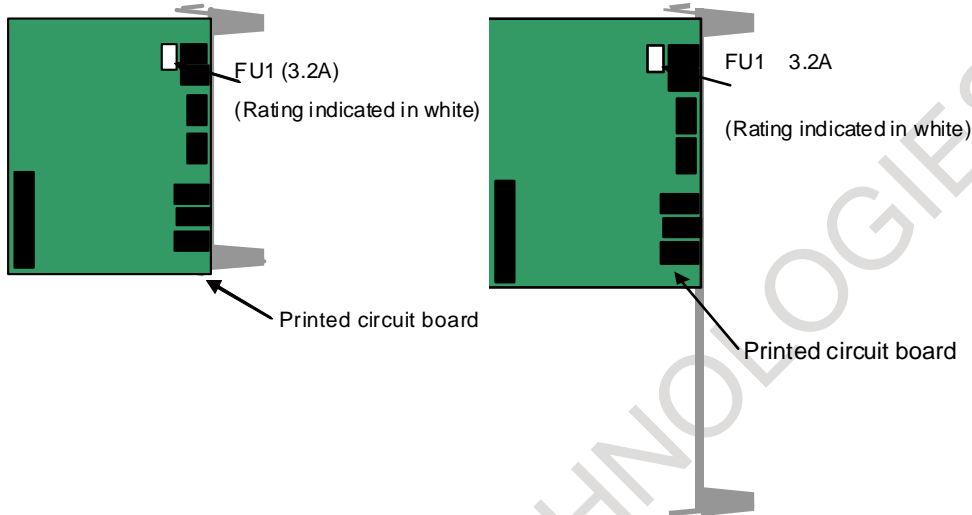

- (2) A20B-2101-0290 and A20B-2101-0881

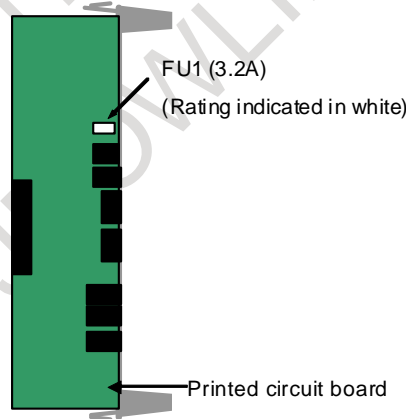

Fuse specification

Symbol	Ordering number
FU1	A60L-0001-0290/LM32C

III. START-UP PROCEDURE FOR βi SVSP

JR AUTOMATION TECHNOLOGIES INC*
JDOWLING

JR AUTOMATION TECHNOLOGIES INC*
JDOWLING

1 OVERVIEW

This part describes the units and components of the FANUC Servo Amplifier β i series. It also explains the following information necessary to start up the servo amplifier:

- Configurations
- Start-up procedure
- Confirmation of the operation
- Periodic maintenance of servo amplifier

JR AUTOMATION TECHNOLOGIES INC*
JDOWLING

2 CONFIGURATIONS

2.1 CONFIGURATIONS

The Servo Amplifier β iSVSP consists of the units and components listed below:

- (1) β i SVSP and β i SVSPc (basic)
- (2) AC reactor (basic)
- (3) Connectors (for connecting cables) (basic)
- (4) Fuses (option)
- (5) Power transformer (option)

Constituent (example)

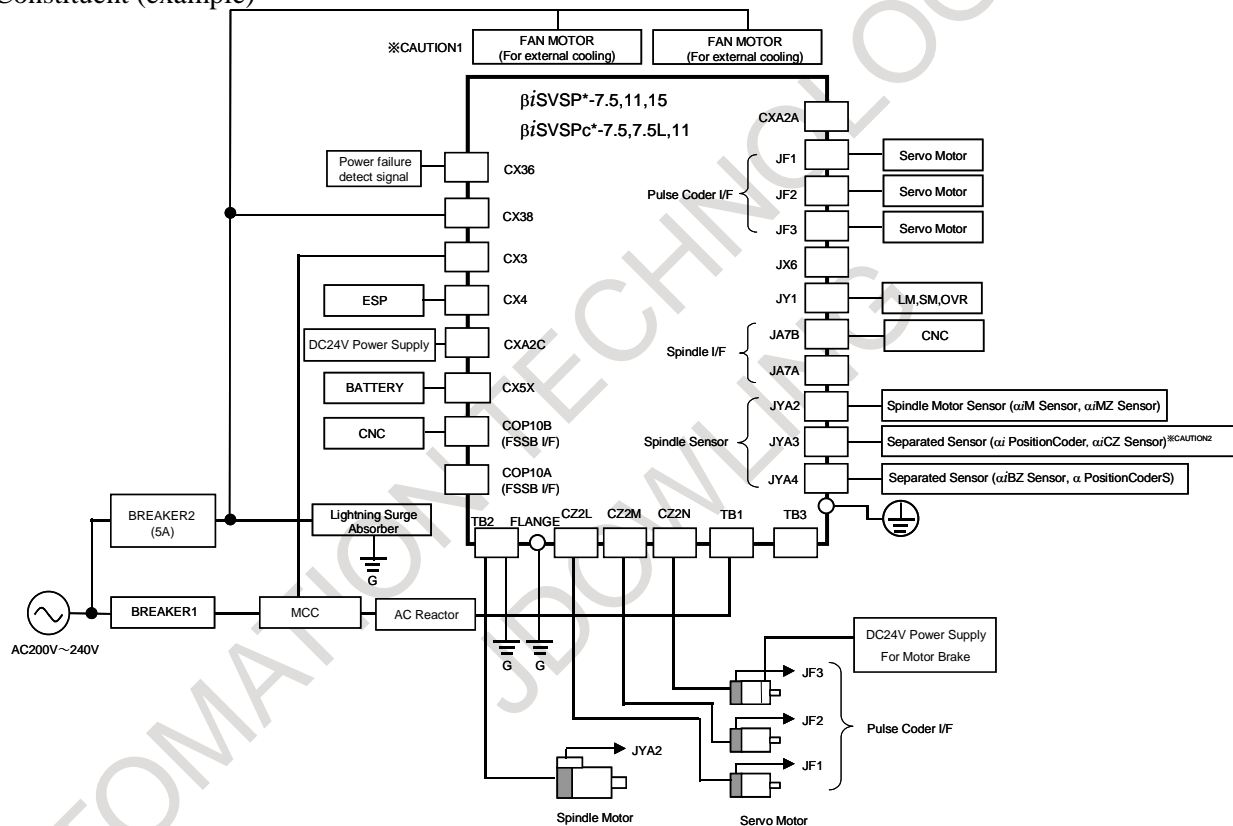

NOTE

- 1 Always install the circuit breakers, magnetic contactor, and AC reactor.
- 2 Use the stabilized power supply 24VDC for the servo amplifier. Power supply 24VDC for the servo amplifier and power supply 24VDC for the motor brake cannot be shared.
- 3 To protect the equipment from lightning surge voltages, install a lightning surge absorber across each pair of power lines and across each power line and the grounding line at the power inlet of the power magnetics cabinet.
- 4 Always ground the grounding terminal (G) on TB2 and the tapped hole for grounding the flange.

NOTE

- 5 The AC reactor is different from the AC line filter, which is designed for another purpose. Substituting one for the other or using one as both the reactor and filter is not allowed.

⚠ CAUTION

- 1 In the $\beta iSVSP^*-7.5$ and -11 , as well as the $\beta iSVSPc^*-7.5L$ and -11 , install only one separated cooling fan motor (for cooling the radiator fin). If installing only one, install it on this side.
- 2 The αiCZ sensor cannot be connected to the $\beta iSVSPc$.

2.2 MAJOR COMPONENTS

2.2.1 $\beta iSVSP$

(1) $\beta iSVSP$

Model	Order specification	Unit specification	Power printed circuit board specification	Control printed circuit board specification	Module printed circuit board specification
$\beta iSVSP20/20-5.5$	A06B-6134-H201#A	A06B-6134-C201#A	A20B-2101-0020	A20B-2101-0012	A20B-2902-0670
$\beta iSVSP20/20-11$	A06B-6134-H202#A	A06B-6134-C202#A	A20B-2101-0021		
$\beta iSVSP40/40-15$	A06B-6134-H203#A	A06B-6134-C203#A	A20B-2101-0022		
$\beta iSVSP20/20/40-5.5$	A06B-6134-H301#A	A06B-6134-C301#A	A20B-2101-0023	A20B-2101-0013	
$\beta iSVSP20/20/40-11$	A06B-6134-H302#A	A06B-6134-C302#A	A20B-2101-0024		
$\beta iSVSP40/40/40-15$	A06B-6134-H303#A	A06B-6134-C303#A	A20B-2101-0025		
$\beta iSVSP20/20-5.5$	A06B-6134-H201#C	A06B-6134-C201#C	A20B-2101-0020	A20B-2101-0012	A20B-2902-0672
$\beta iSVSP20/20-11$	A06B-6134-H202#C	A06B-6134-C202#C	A20B-2101-0021		
$\beta iSVSP40/40-15$	A06B-6134-H203#C	A06B-6134-C203#C	A20B-2101-0022		
$\beta iSVSP20/20/40-5.5$	A06B-6134-H301#C	A06B-6134-C301#C	A20B-2101-0023	A20B-2101-0013	
$\beta iSVSP20/20/40-11$	A06B-6134-H302#C	A06B-6134-C302#C	A20B-2101-0024		
$\beta iSVSP40/40/40-15$	A06B-6134-H303#C	A06B-6134-C303#C	A20B-2101-0025		
$\beta iSVSP20/20-7.5$	A06B-6134-H201#D	A06B-6134-C201#D	A20B-2101-0440	A20B-2101-0450	-
$\beta iSVSP20/20-11$	A06B-6134-H202#D	A06B-6134-C202#D	A20B-2101-0441		
$\beta iSVSP40/40-15$	A06B-6134-H203#D	A06B-6134-C203#D	A20B-2101-0022		
$\beta iSVSP20/20/40-7.5$	A06B-6134-H301#D	A06B-6134-C301#D	A20B-2101-0581	A20B-2101-0452	-
$\beta iSVSP20/20/40-11$	A06B-6134-H302#D	A06B-6134-C302#D	A20B-2101-0582		
$\beta iSVSP40/40/40-15$	A06B-6134-H303#D	A06B-6134-C303#D	A20B-2101-0025		
$\beta iSVSP40/40/80-15$	A06B-6134-H313#D	A06B-6134-C313#D	A20B-2101-0029		

(2) $\beta iSVSP$ for $0i/0i$ Mate-D series CNC

Model	Order specification	Unit specification	Power printed circuit board specification	Control printed circuit board specification	Module printed circuit board specification
$\beta iSVSP20/20-7.5$	A06B-6164-H201#H580	A06B-6164-C201	A20B-2101-0440	A20B-2101-0710	A20B-2902-0671
$\beta iSVSP20/20-11$	A06B-6164-H202#H580	A06B-6164-C202	A20B-2101-0441		
$\beta iSVSP40/40-15$	A06B-6164-H223#H580	A06B-6164-C223	A20B-2101-0022		
$\beta iSVSP40/40-18$	A06B-6164-H224#H580	A06B-6164-C224	A20B-2102-0300	A20B-2102-0206	A20B-2902-0674
$\beta iSVSP80/80-18$	A06B-6164-H244#H580	A06B-6164-C244	A20B-2102-0302		
$\beta iSVSP20/20/40-7.5$	A06B-6164-H311#H580	A06B-6164-C311	A20B-2101-0581	A20B-2101-0711	A20B-2902-0671
$\beta iSVSP20/20/40-11$	A06B-6164-H312#H580	A06B-6164-C312	A20B-2101-0582		
$\beta iSVSP40/40/40-15$	A06B-6164-H333#H580	A06B-6164-C333	A20B-2101-0025		
$\beta iSVSP40/40/80-15$	A06B-6164-H343#H580	A06B-6164-C343	A20B-2101-0029		

Model	Order specification	Unit specification	Power printed circuit board specification	Control printed circuit board specification	Module printed circuit board specification
β iSVSP40/40/80-18	A06B-6164-H344#H580	A06B-6164-C344	A20B-2102-0301	A20B-2102-0207	A20B-2902-0674
β iSVSP80/80/80-18	A06B-6164-H364#H580	A06B-6164-C364	A20B-2101-0028		
β iSVSP20/20-7.5	A06B-6165-H201#H560	A06B-6165-C201	A20B-2101-0440	A20B-2101-0710	A20B-2902-0672
β iSVSP20/20-11	A06B-6165-H202#H560	A06B-6165-C202	A20B-2101-0441		
β iSVSP40/40-15	A06B-6165-H223#H560	A06B-6165-C223	A20B-2101-0022	A20B-2101-0711	
β iSVSP20/20/40-7.5	A06B-6165-H311#H560	A06B-6165-C311	A20B-2101-0581		
β iSVSP20/20/40-11	A06B-6165-H312#H560	A06B-6165-C312	A20B-2101-0582		
β iSVSP40/40/40-15	A06B-6165-H333#H560	A06B-6165-C333	A20B-2101-0025		
β iSVSP40/40/80-15	A06B-6165-H343#H560	A06B-6165-C343	A20B-2101-0029		

2.2.2 β iSVSPc

Model	Order specification	Unit specification	Power printed circuit board specification	Control printed circuit board specification	Module printed circuit board specification
β iSVSPc20/20-7.5	A06B-6167-H201#H560	A06B-6167-C201	A20B-2101-0440	A20B-2101-0710	A20B-2902-0673
β iSVSPc20/20-7.5L	A06B-6167-H209#H560	A06B-6167-C209	A20B-2101-0440		
β iSVSPc20/20-11	A06B-6167-H202#H560	A06B-6165-C202	A20B-2101-0441	A20B-2101-0711	
β iSVSPc20/20/20-7.5	A06B-6167-H301#H560	A06B-6167-C301	A20B-2102-0104		
β iSVSPc20/20/20-7.5L	A06B-6167-H309#H560	A06B-6167-C309	A20B-2102-0104		
β iSVSPc20/20/20-11	A06B-6167-H302#H560	A06B-6165-C302	A20B-2102-0105		

3 START-UP PROCEDURE

3.1 START-UP PROCEDURE (OVERVIEW)

Make sure that the specifications of the CNC, servo motors, spindle motors, servo amplifiers, and other units you received are exactly what you ordered, and these units are connected correctly. Then, turn on the power.

The items to be checked are described below.

No.	Description	Check method
Checking the installation of the servo amplifier		
1	Specification of the servo amplifier and servo motor	Check the combination of the servo amplifier and the servo motor is correct. Refer to the Servo Amplifier βi series Descriptions (B-65322EN).
2	Packing of the flange	Check the supplied packing is attached properly and that there is no gap between the control panel and the amplifier flange.
3	Keeping maintenance areas	Keep maintenance areas above and below the amplifier. For details, refer to the Servo Amplifier βi series Descriptions (B-65322EN).
4	Prevention of contact with conductive section	Check a protective plate is attached to the DC link terminal board. For details, refer to the Servo Amplifier βi series Descriptions (B-65322EN).
5	Measure against entry of coolant	Take a measure to prevent electroconductive, flammable, and corrosive material as well as mist and water drop from getting in the unit. For keeping of the effective closeness of the control panel, refer to Appendix G "EXAMPLES OF RECOMMENDED POWER MAGNETICS CABINETS FOR SERVO AMPLIFIER INSTALLATION" in the αi series Servo Amplifier Descriptions" (B-65412EN).
Checking the wiring for the servo amplifier		
6	Screwing to the terminal block	When connecting wires to the servo amplifier terminal board, be sure to tighten the screws with a proper torque. For the detail of the tightening torque for the terminal board screws, refer to the Servo Amplifier βi series Descriptions (B-65322EN).
7	Connecting protective ground	Use a proper cable for grounding in order to prevent electrical shocks at a ground fault. For details, refer to Subsection 9.3.1.7 of the Servo Amplifier βi series Descriptions" (B-65322EN).
8	Installing the lightning surge protector	In order to prevent damage due to a surge voltage applied to the input power supply, install a lightning surge protector. For details, refer to the Servo Amplifier βi series Descriptions" (B-65322EN).
9	Measure against noise	Check that ground wires, including feedback cable shielding clamps, are connected to proper places to maintain a stable operation of the machine. For details, refer to the Servo Amplifier βi series Descriptions" (B-65322EN).
10	Phase order of motor power lines	If the phase order of motor power lines is incorrect, the motor may operate unexpectedly. Make sure that the motor power lines are connected correctly.
11	Checking the axis to which the motor feedback wire and power wire are connected	If the axis to which the motor feedback wire and power wire are connected is incorrect, the motor may operate unexpectedly. So, make sure that the connection is correct.
12	Connection of batteries	Do not connect the built-in batteries in parallel. Please make sure, if the built-in batteries are used with an amp-to-amp battery connection cable (CXA2A/C or BATL (B3)) attached, they may be connected in parallel. For details, refer to the Servo Amplifier βi series Descriptions" (B-65322EN).
Check during startup of operation		
13	Checking the power supply voltage	Before turning on the power, check that the power supply voltage is in its proper range. For details of the power supply voltage specification, refer to the Servo Amplifier βi series Descriptions" (B-65322EN).

No.	Description	Check method
14	Setting the ground fault breaker	Use a ground fault interrupter that supports inverters. For information about leakage current, refer to the Servo Amplifier β i series Descriptions (B-65322EN).
15	Checking the control power	Check that the voltage of the 24 V power supply for amplifiers is in its proper range and the selected current capacity is proper. For details, refer to the Servo Amplifier β i series Descriptions (B-65322EN).
16	Setting parameters	Set initial parameters with reference to Section 3.3.
17	Handling early failures	To solve start-up problems, such as being impossible to turn on the power, motor failing to rotate, and occurrence of an alarm, see Chapter 4 of this document.

3.2 CONNECTING THE POWER

3.2.1 Checking the Voltage and Capacity of the Power

Before connecting the power, you should measure the AC power voltage.

Table 3.2.1(a) Action for the AC power (200-V input type)

Permissible voltage fluctuation width	Nominal voltage	Action
-15% +10%	3-phase 200 to 240V	Permitted. Note) If the voltage is below the rated value, the rated output may not be obtained.
-15% +10%	380 to 550V	Not permitted. This power line must be connected through an insulation transformer to step down the voltage to 200 V.

Tables 3.2.1 (b), (c), and (d) list the input power specification for the power supply module. Use a power source with sufficient capacity so that the system will not malfunction due to a voltage drop even at a time of peak load.

(1) β iSVSP

Table 3.2.1(b) AC power voltage specifications (200-V input type)

Specification	A06B-6134-H201#A A06B-6134-H201#C	A06B-6134-H202#A A06B-6134-H202#C	A06B-6134-H203#A A06B-6134-H203#C
Model	β iSVSP20/20-5.5	β iSVSP20/20-11	β iSVSP40/40-15
Nominal voltage rating	200 to 240VAC -15%,+10%		
Power source frequency	50/60Hz \pm 1Hz		
Power source capacity (for the main circuit) [kVA]	9	17	22
Power source capacity (for the control circuit)	24V 1.5A \pm 10%		

Specification	A06B-6134-H301#A A06B-6134-H301#C	A06B-6134-H302#A A06B-6134-H302#C	A06B-6134-H303#A A06B-6134-H303#C
Model	β iSVSP20/20/40-5.5	β iSVSP20/20/40-11	β iSVSP40/40/40-15
Nominal voltage rating	200 to 240VAC -15%,+10%		
Power source frequency	50/60Hz \pm 1Hz		
Power source capacity (for the main circuit) [kVA]	9	17	22
Power source capacity (for the control circuit)	24V 1.5A \pm 10%		

Specification	A06B-6134-H201#D	A06B-6134-H202#D	A06B-6134-H203#D
Model	β iSVSP20/20-7.5	β iSVSP20/20-11	β iSVSP40/40-15
Nominal voltage rating	200 to 240VAC -15%,+10%		
Power source frequency	50/60Hz \pm 1Hz		
Power source capacity (for the main circuit) [kVA]	13	18	24
Power source capacity (for the control circuit)	24V 1.5Amax \pm 10%		

Specification	A06B-6134-H301#D	A06B-6134-H302#D	A06B-6134-H303#D	A06B-6134-H313#D
Model	β iSVSP20/20/40-5.5	β iSVSP20/20/40-11	β iSVSP40/40/40-15	β iSVSP40/40/80-15
Nominal voltage rating	200 to 240VAC -15%,+10%			
Power source frequency	50/60Hz \pm 1Hz			
Power source capacity (for the main circuit) [kVA]	13	19	24	25
Power source capacity (for the control circuit)	24V 1.5Amax \pm 10%			

(2) β iSVSP for 0i/0i Mate-D series CNC

Table 3.2.1(c) AC power voltage specifications (200-V input type)

Specification	A06B-6164 -H201#H580 A06B-6165 -H201#H560	A06B-6164 -H202#H580 A06B-6165 -H202#H560	A06B-6164 -H223#H580 A06B-6165 -H223#H560	A06B-6164 -H224#H580	A06B-6164 -H244#H580
Model	β iSVSP20/20-7.5	β iSVSP20/20-11	β iSVSP40/40-15	β iSVSP40/40-18	β iSVSP80/80-18
Nominal voltage rating	200 to 240VAC -15%,+10%				
Power source frequency	50/60Hz \pm 1Hz				
Power source capacity (for the main circuit) [kVA]	11	14	21	26	27
Power source capacity (for the control circuit)	24V 2.0Amax \pm 10%				

Specification	A06B-6164 -H311#H580 A06B-6165 -H311#H560	A06B-6164 -H312#H580 A06B-6165 -H312#H560	A06B-6164 -H333#H580 A06B-6165 -H333#H560	A06B-6164 -H343#H580 A06B-6165 -H343#H560	A06B-6164 -H344#H580	A06B-6164 -H364#H580
Model	β iSVSP20/20/40 -7.5	β iSVSP20/20/40 -11	β iSVSP40/40/40 -15	β iSVSP40/40/80 -15	β iSVSP40/40/80 -18	β iSVSP80/80/80 -18
Nominal voltage rating	200 to 240VAC -15%,+10%					
Power source frequency	50/60Hz \pm 1Hz					
Power source capacity (for the main circuit) [kVA]	13	16	23	24	28	29
Power source capacity (for the control circuit)	24V 2.0Amax \pm 10%					

(3) β iSVSPc

Table 3.2.1(c) AC power voltage specifications (200-V input type)

Specification	A06B-6167-H201#H560	A06B-6167-H209#H560	A06B-6167-H202#H560
Model	β iSVSPc20/20-7.5	β iSVSPc20/20-7.5L	β iSVSPc20/20-11
Nominal voltage rating	200 to 240VAC -15%,+10%		
Power source frequency	50/60Hz \pm 1Hz		
Power source capacity (for the main circuit) [kVA]	11	11	14
Power source capacity (for the control circuit)	24V 1.5A \pm 10%		

Specification	A06B-6167-H301#H560	A06B-6167-H309#H560	A06B-6167-H302#H560
Model	β iSVSPc20/20/20-7.5	β iSVSPc20/20/20-7.5L	β iSVSPc20/20/20-11
Nominal voltage rating	AC200V~240V -15%,+10%		
Power source frequency	50/60Hz \pm 1Hz		
Power source capacity (for the main circuit) [kVA]	12	12	15
Power source capacity (for the control circuit)	24V 1.5A \pm 10%		

3.2.2 Connecting a Protective Ground

Check that a protective ground is connected correctly with reference to individual items in Chapter 6 "INSTALLATION" in the FANUC SERVO AMPLIFIER β i series Descriptions (B-65322EN).

3.2.3 Selecting the Ground Fault Interrupter That Matches the Leakage Current

Check that a ground fault breaker is selected correctly with reference to individual items in Chapter 6 "INSTALLATION" in the FANUC SERVO AMPLIFIER β i series Descriptions (B-65322EN).

3.3 INITIALIZING PARAMETERS

(1) Servo motor

For the initialization of servo parameters, refer to the following manual:

FANUC AC SERVO MOTOR α i series / FANUC AC SERVO MOTOR β i series/ FANUC LINEAR LiS series / FANUC BUILT-IN SERVO MOTOR DiS series Parameter Manual (B-65270EN)

(2) Spindle motor

For the initialization of spindle parameters, refer to the following manual:

FANUC AC SPINDLE MOTOR α i series / FANUC AC SPINDLE MOTOR β i series /FANUC BUILT-IN SPINDLE MOTOR Bi series Parameter Manual (B-65280EN)

4 CONFIRMATION OF THE OPERATION

4.1 OUTLINE OF β iSVSP

4.1.1 Connector and STATUS LED Locations

(1) β iSVSP(A06B-6134-H***#A,#C)

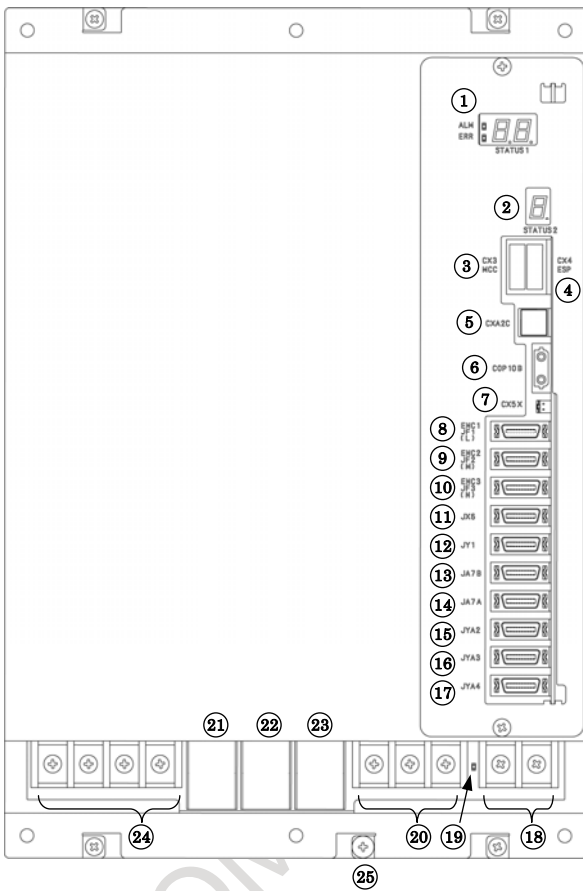

No.	Name	Remarks
1	STATUS1	Status LED : spindle
2	STATUS2	Status LED : servo
3	CX3	Main power MCC control signal
4	CX4	Emergency stop signal (ESP)
5	CXA2C	24VDC power input
6	COP10B	Servo FSSB I/F
7	CX5X	Absolute Pulsecoder battery
8	JF1	Pulsecoder : L axis
9	JF2	Pulsecoder : M axis
10	JF3	Pulsecoder : N axis
11	JX6	Power outage backup module
12	JY1	Load meter, speedometer, analog override
13	JA7B	Spindle interface input
14	JA7A	Spindle interface output
15	JYA2	Spindle sensor M_i, M_{Zi}
16	JYA3	αi position coder
17	JYA4	(Unused)
18	TB3	DC link terminal block
19		DC link charge LED ^(Warning)
20	TB1	Main power supply connection terminal board
21	CZ2L	Servo motor power line : L axis
22	CZ2M	Servo motor power line : M axis
23	CZ2N	Servo motor power line : N axis
24	TB2	Spindle motor power line
25		Tapped hole for grounding the flange

WARNING

Do not touch any component in the module or any connected cable when LED 19 is on, because it is dangerous.

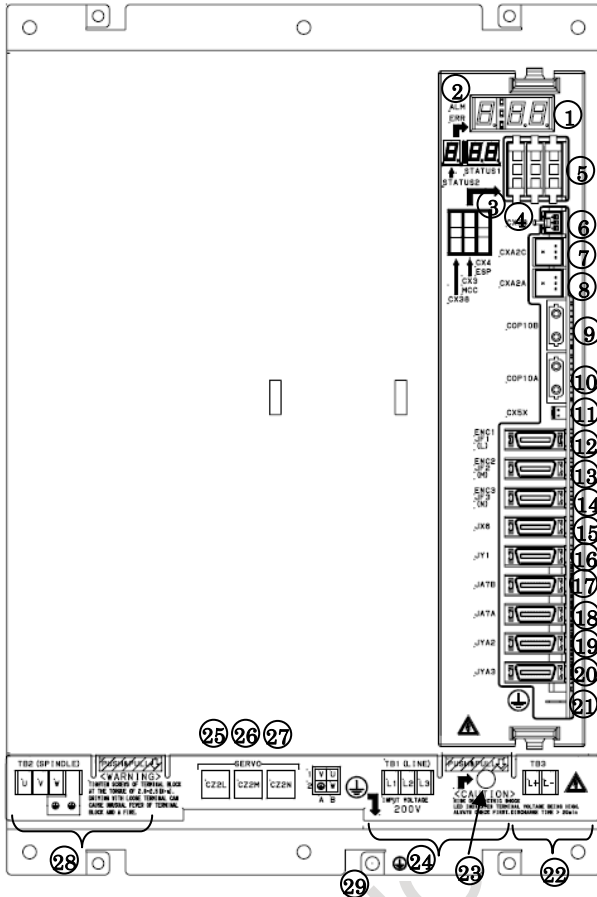
(2) β iSVSP(A06B-6134-H***#D)

No.	Name	Remarks
1	STATUS1	Status LED : spindle
2	STATUS2	Status LED : servo
3	CX36	Power outage output
4	CX38	Power outage input
5	CX3	Main power MCC control signal
6	CX4	Emergency stop signal (ESP)
7	CXA2C	24VDC power input
8	CXA2A	24VDC power output
9	COP10B	Servo FSSB I/F
10	COP10A	Servo FSSB I/F
11	CX5X	Absolute Pulsecoder battery
12	JF1	Pulsecoder : L axis
13	JF2	Pulsecoder : M axis
14	JF3	Pulsecoder : N axis
15	JX6	Power outage backup module
16	JY1	Load meter, speedometer, analog override
17	JA7B	Spindle interface input
18	JA7A	Spindle interface output
19	JYA2	Spindle sensor M_i, M_{Zi}
20	JYA3	α_i position coder External one-rotation signal
21		Signal grounding terminal
22	TB3	DC link terminal block
23		DC link charge LED (Warning)
24	TB1	Main power supply connection terminal board
25	CZ2L	Servo motor power line : L axis
26	CZ2M	Servo motor power line : M axis
27	CZ2N	Servo motor power line : N axis
28	TB2	Spindle motor power line
29		Tapped hole for grounding the flange



⚠ WARNING

Do not touch any component in the module or any connected cable when LED 23 is on, because it is dangerous.

4. CONFIRMATION OF THE OPERATION

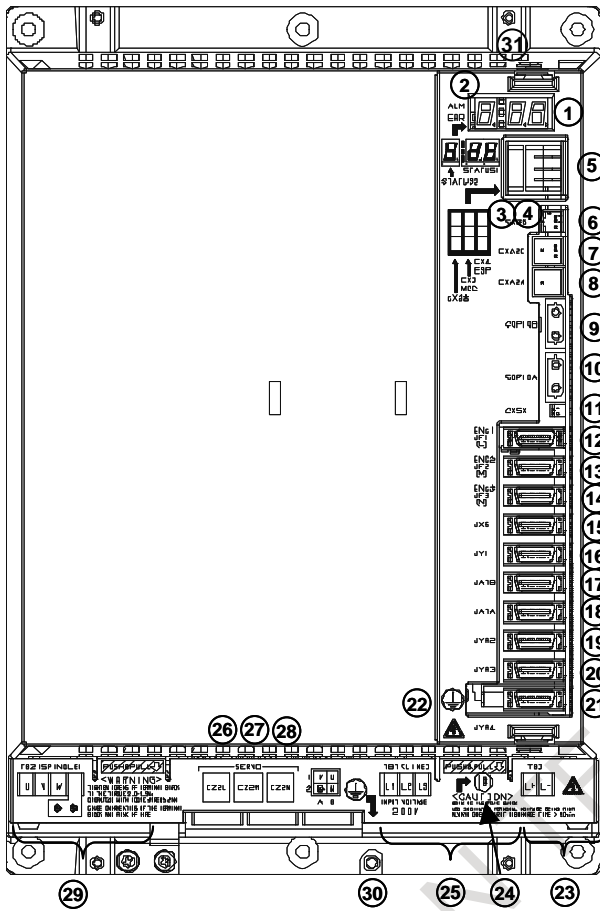
(3) β iSVSP(A06B-6164-H***#H580, A06B-6165-H***#H560), β iSVSPc(A06B-6167-H***#H560)



No.	Name	Remarks
1	STATUS1	Status LED : spindle
2	STATUS2	Status LED : servo
3	CX38	Power outage input
4	CX3	Main power MCC control signal
5	CX4	Emergency stop signal (ESP)
6	CX36	Power outage output
7	CXA2C	24VDC power input
8	CXA2A	24VDC power output
9	COP10B	Servo FSSB I/F
10	COP10A	Servo FSSB I/F
11	CX5X	Absolute Pulsecoder battery
12	JF1	Pulsecoder : L axis
13	JF2	Pulsecoder : M axis
14	JF3	Pulsecoder : N axis
15	JX6	Power outage backup module
16	JY1	Load meter, speedometer, analog override
17	JA7B	Spindle interface input
18	JA7A	Spindle interface output
19	JYA2	Spindle sensor α i M, α i MZ
20	JYA3	Separate spindle sensor (α i position coder, α iCZ sensor) External one-rotation signal
21	JYA 4	Separate spindle sensor (α position coder S, α iBZ sensor)
22		Signal grounding terminal
23	TB3	DC link terminal block
24	V4	DC link charge LED (Warning)
25	TB1	Main power supply connection terminal board
26	CZ2L	Servo motor power line : L axis
27	CZ2M	Servo motor power line : M axis
28	CZ2N	Servo motor power line : N axis
29	TB2	Spindle motor power line
30		Tapped hole for grounding the flange
31	CN4	Connector for internal cooling fan

⚠ WARNING

Do not touch any component in the module or any connected cable when LED 23 is on, because it is dangerous.

4.1.2 Start-up Procedure

Check each item according to the procedure described below.

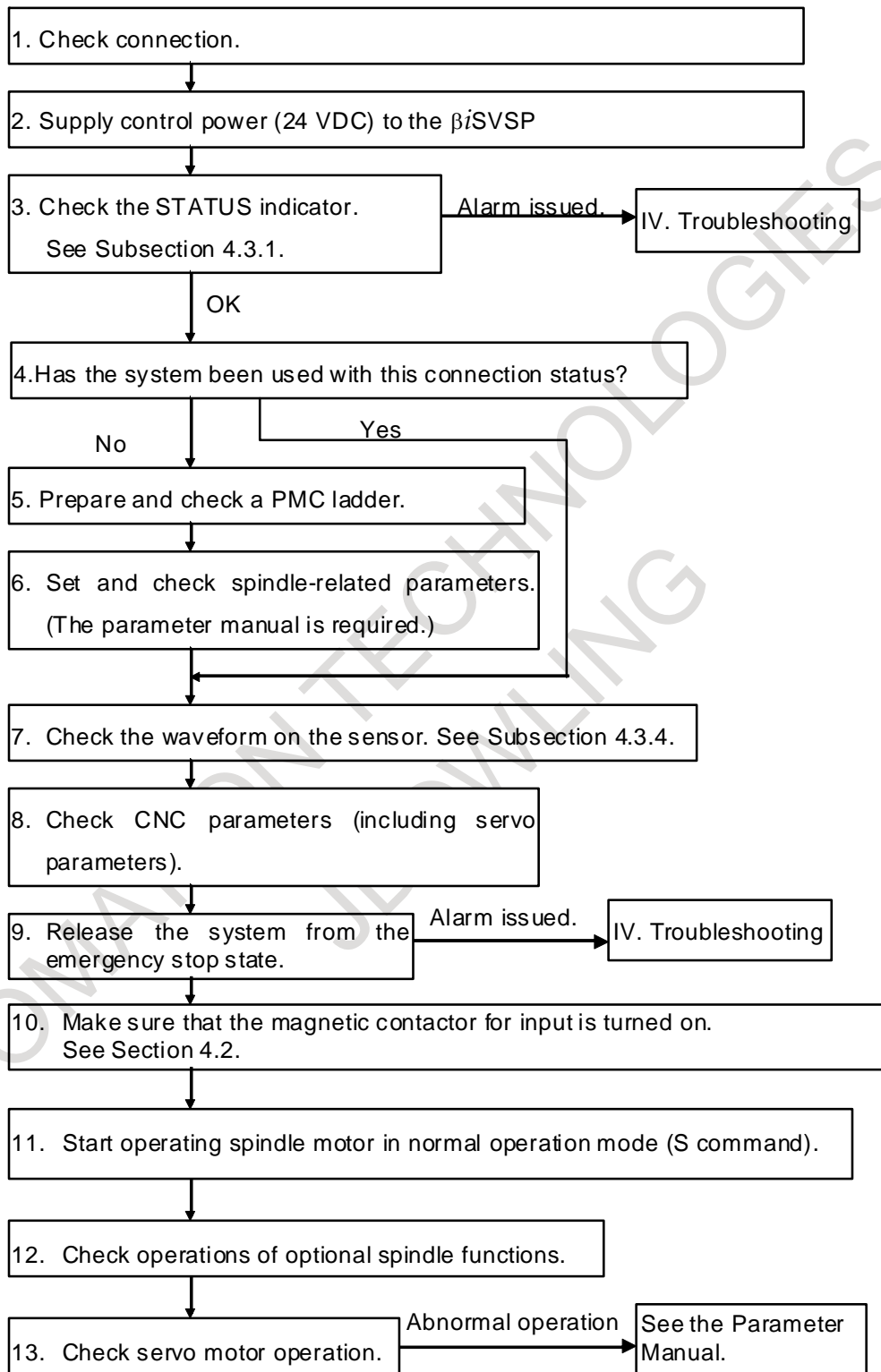

4.2 β iSVSP COMMON POWER SUPPLY UNIT

4.2.1 The LED (STATUS Indicator) Is Off.

Table 4.2.1 Check method and action

No.	Cause of trouble	Check method	Action
1	24-VDC power for the control circuit not supplied	Check that power is connected to connector CXA2C.	
2	Blown fuse in the control circuit	Check whether FU1 has blown.	Replace the fuse. If the fuse blows again after the replacement, replace the printed circuit board.
3	Incorrect wiring	Check the wiring according to the Descriptions.	
4	24VDC power output (CXA2A) short-circuited	Check whether 24VDC power output has been short-circuited.	Remove the cause of a short circuit.
5	Load of 24VDC power output (CXA2A) too large	Check whether the number of amplifiers connected to 24VDC power output (CXA2A) exceeds a specified number or a device other than an amplifier is connected to 24VDC power output.	
6	Faulty power supply circuit on the printed circuit board	The LED indicator operates on the +5-V power supply. Check the control power voltage.	Replace the printed circuit board, driver board, or power distribution board.

4.2.2 Checking Method when Magnetic Contactor Is not Switched On

- (1) The system is still in an emergency stop status.
→ Check the connection.
- (2) There is a connector problem.
 - (a) Check that the connectors are attached to correct locations.
- (3) The power for driving the magnetic contactor is not supplied.
→ Check the voltage across the both ends of the coil of the magnetic contactor.
- (4) The relay for driving the magnetic contactor is defective.
→ Check that a circuit between pins CX3-1 and CX3-3 of connector is closed and opened.

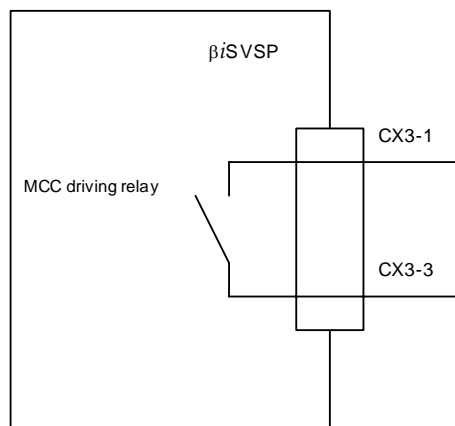

- (5) The β iSVSP is defective.
→ Replace the defective β iSVSP.

4.2.3 Check Terminal on the Printed-circuit Board

The input current check signal is output to connector JX6 on the β iSVSP. To observe the output, use the servo check pin board A06B-6071-K290 (see below).

Table 4.2.3 (a) Check pins

Check pin	Description	Location of observation	Remark
IR	L1 phase (R-phase) current	JX6-pin1	The "+" sign with respect to the input of the amplifier. If the L1 or L2 phase current exceeds the overcurrent alarm level, an alarm condition occurs in the β iSVSP.
IS	L2 phase (S-phase) current	JX6-pin2	
0V	Reference point of observation	JX6-pin12,14,16	

Table 4.2.3 (b) IR and IS current conversion value

Model	Current conversion
β iSVSP*-5.5	133A/1V (2.5 V at the center)
β iSVSP*-7.5	133A/1V (2.5 V at the center)
β iSVSP*-11	133A/1V (2.5 V at the center)
β iSVSP*-15	200A/1V (2.5 V at the center)
β iSVSP*-18	200A/1V (2.5 V at the center)

About the servo check pin board A06B-6071-K290

The servo check pin board can be used to observe signals in the β iSVSP.

(1) Specification

Order specification	Description	Remark
A06B-6071-K290	Printed-circuit board A20B-1005-0340	Printed-circuit board with check pins mounted
	Cable A660-2042-T031#L200R0	20-conductor one-to-one cable Length : 200mm

Printed-circuit board : A20B-1005-0340

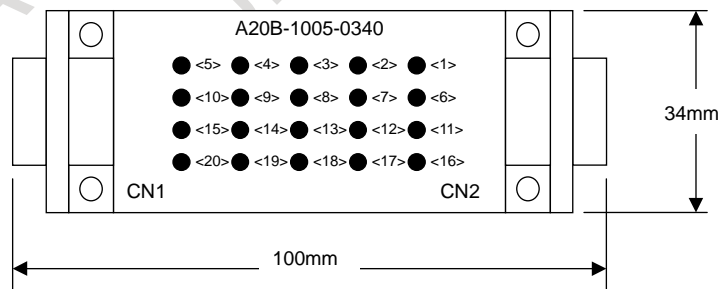

Cable : A660-2042-T031#L200R0

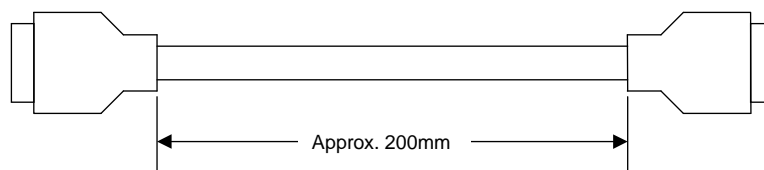

One-to-one wiring is provided between CN1 and CN2.
The connector pin numbers correspond to the check pin numbers.

4. CONFIRMATION OF THE OPERATION

(2) Connection

Connect the cable to the connector JX6 at the front of the β iSVSP.

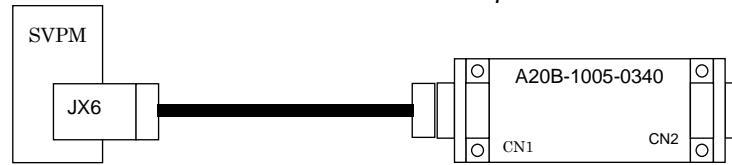

4.3 β iSVSP SPINDLE UNIT

4.3.1 STATUS 1 Indicator

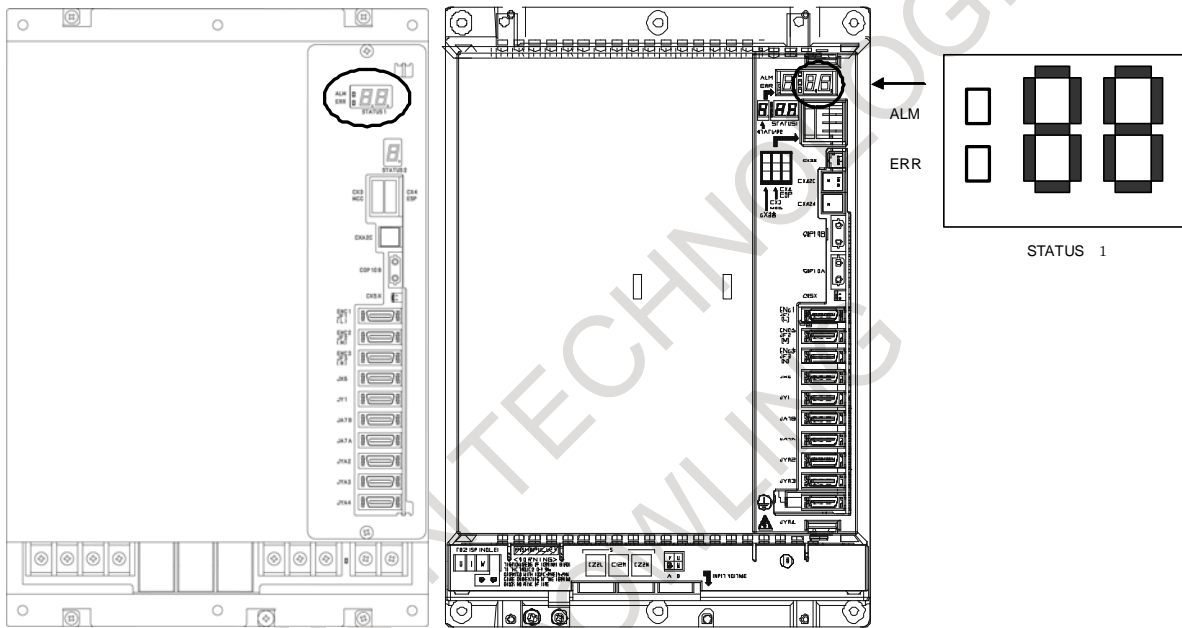

No.	ALM	ERR	STATUS1	Description
1			No indication	The control power supply has not been switched on. The power supply circuit is defective.
2			80	For about 1.0 s after the control power supply is switched on, the lower two digits of the spindle software series No. are indicated. Example) 80: Software series No. 9D80
3			04	The spindle software edition number is displayed for about 1.0 s. 01, 02, 03, and so on correspond to A, B, C, and so on, respectively. Example) 04: software edition D
4			-- Blinking	The CNC has not been switched on. The machine is waiting for serial communication and parameter loading to end.
5			-- Lighting	Parameter loading has ended. The motor is not supplied with power.
6			00	The motor is supplied with power.
7	Lighting		01 or above is displayed.	Alarm state The β iSVSP is not operable. See Chapter 1 of Part IV.
8		Lighting	01 or above is displayed.	Error state Incorrect parameter setting or improper sequence.

4.3.2 Troubleshooting at Startup

4.3.2.1 The STATUS 1 indicator is blinking with "--."

- (1) When no spindle communication alarm message is indicated on the CNC
Check whether the CNC software option setting or bit setting is correct.
- (2) When a communication alarm message is indicated on the CNC

No.	Cause of trouble	Check method	Action
1	The cable is incorrect.	Note that the cable used for connecting an electric/optical adapter and the cable connected directly to the CNC differ in specifications.	Replace the cable with a correct cable.
2	The cable is defective.	Check the connector housing section.	Repair or replace the cable.
3	The printed circuit board is defective.		Replace the unit.

4.3.2.2 The motor does not turn.

- (1) When "--" is indicated on the STATUS 1 indicator of the β iSVSP
Check whether spindle control signals are input. (An example for the first spindle is shown below.)

FS0i	#7	#6	#5	#4	#3	#2	#1	#0
G070	MRDYA		SFRA	SRVA				
G071							*ESPA	
G029		*SSTP						
G030	SOV7	SOV6	SOV5	SOV4	SOV3	SOV2	SOV1	SOV0

- (2) When "00" is indicated on the STATUS 1 indicator of the β iSVSP
No spindle speed command is input.
Refer to Chapter 1 in "FANUC AC SPINDLE MOTOR α i series / FANUC AC SPINDLE MOTOR β i series / FANUC BUILT-IN SPINDLE MOTOR Bi series Parameter Manual (B-65280EN)," and check related parameters.
- (3) When an alarm number is indicated on the STATUS 1 indicator of the β iSVSP
See the description of the alarm number in Part IV.

4.3.2.3 A specified speed cannot be obtained.

- (1) When the speed always differs from a specified speed
Check parameters.
Refer to Chapter 1 in "FANUC AC SPINDLE MOTOR α i series / FANUC AC SPINDLE MOTOR β i series / FANUC BUILT-IN SPINDLE MOTOR Bi series Parameter Manual (B-65280EN)," and check related parameters.
- (2) When an alarm number is indicated on the STATUS 1 indicator of the β iSVSP
See the description of the alarm number in Part IV.

4.3.2.4 When cutting is not performed, the spindle vibrates, making noise.

- (1) When the spindle vibrates at a particular speed
 Check whether the spindle also vibrates when the motor is turning by inertia. If the same vibration occurs when the motor is turning by inertia, investigate the source of mechanical vibration. There are several methods for turning the spindle by inertia, as described below. Because these methods involve machine sequences, be sure to consult with the machine tool builder.
- A. Input signal MPOF(FS30i:G73#2, FS15i:G228#2) to 1 immediately causes the spindle to turn by inertia.
 - B. Set bit 2 (ALSP) of parameter No. 4009 (FS30i) or No. 3009 (FS15i) to 1. Then, when the power to the CNC is turned off during spindle rotation, the spindle turns by inertia. At this time, on the spindle amplifier, Alarm 24 is indicated.
- (2) When the spindle vibrates regardless of the speed (also during a control stop)
- A. Check and adjust the waveform of the spindle sensor. For details, see Subsection 4.3.4.
 - B. Check that the motor part number matches its parameters.
 Refer to FANUC AC SPINDLE MOTOR α i series / FANUC AC SPINDLE MOTOR β i series /FANUC BUILT-IN SPINDLE MOTOR Bi series Parameter Manual (B-65280EN) for details.
 - C. Adjust the velocity loop gain and so forth.
 Refer to FANUC AC SPINDLE MOTOR α i series / FANUC AC SPINDLE MOTOR β i series /FANUC BUILT-IN SPINDLE MOTOR Bi series Parameter Manual (B-65280EN) for details.

4.3.2.5 An overshoot or hunting occurs.

Refer to FANUC AC SPINDLE MOTOR α i series / FANUC AC SPINDLE MOTOR β i series /FANUC BUILT-IN SPINDLE MOTOR Bi series Parameter Manual (B-65280EN), and adjust parameters.

4.3.2.6 Cutting power weakens or acceleration/deceleration slows down.

- (1) When the load meter does not indicate the maximum output
 - A. A mechanical cause such as a belt slip may occur.
- (2) When the load meter indicates the maximum output
 - A. Check whether the torque limit signal is input incorrectly.

FS0i	#7	#6	#5	#4	#3	#2	#1	#0
G070							TLMHA	TLMLA

- B. When the α iBZ sensor is used, the sensor gear may slide over the spindle during acceleration.
- C. The motor part number may not appropriate for the specific parameters.
 Refer to FANUC AC SPINDLE MOTOR α i series / FANUC AC SPINDLE MOTOR β i series /FANUC BUILT-IN SPINDLE MOTOR Bi series Parameter Manual (B-65280EN) for details.
- D. The output limit pattern may be set incorrectly.
 Refer to FANUC AC SPINDLE MOTOR α i series / FANUC AC SPINDLE MOTOR β i series /FANUC BUILT-IN SPINDLE MOTOR Bi series Parameter Manual (B-65280EN) for details.

4.3.3 Status Error Indication Function

When there is a sequence or parameter error, the error LED (yellow) in the STATUS 1 indicator of the β iSVSP goes on with an error code displayed. This can ease troubleshooting at the time of machine startup.

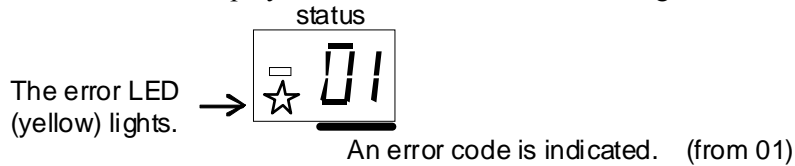

If the β iSVSP spindle unit does not operate for a particular function, check whether a status error is indicated in β iSVSP STATUS1.

No.	Description	Action
01	Although neither *ESP (emergency stop signal) (there are two types of signals, a PMC signal and PSM contact signal) nor MRDY (machine ready signal) has been input, SFR (forward rotation signal), SRV (reverse rotation signal), or ORCM (orientation command) is input.	Check the *ESP and MRDY sequences. For MRDY, pay attention to the parameter that specifies whether to use the MRDY signal (bit 0 of parameter No. 4001).
03	Although parameter settings are such that there is no position sensor (position control is not to be performed, that is, bits 3, 2, 1, and 0 of parameter No. 4002 are, respectively, 0, 0, 0, and 0), a Cs axis contour control command has been issued. In this case, the motor is not activated.	Check setting of the parameter.
04	Although parameter settings are such that there is no position sensor (position control is not to be performed, that is, bits 3, 2, 1, and 0 of parameter No. 4002 are, respectively, 0, 0, 0, and 0), a servo mode (such as rigid tapping or Cs axis control) command or spindle synchronization control command has been issued. In this case, the motor is not activated.	Check setting of the parameter.
05	Although optional parameter for the orientation function is not set, an ORCM (orientation command) is input.	Check setting of the parameter for orientation.
06	Although optional parameter for the output switching option is not set, low-speed winding is selected (RCH = 1).	Check setting of the parameter for output switching and the power line status signal (RCH).
07	Although Cs contour control mode is input, neither SFR (forward rotation signal) nor SRV (reverse rotation signal) is input.	Check the sequence.
08	Although servo mode (such as rigid tapping or Cs axis control) control command is input, neither SFR (forward rotation signal) nor SRV (reverse rotation signal) is input.	Check the sequence.
09	Although spindle synchronization control command is input, neither SFR (forward rotation signal) nor SRV (reverse rotation signal) is input.	Check the sequence.
10	Although Cs contour control command is input, another operation mode (servo mode, spindle synchronization, or orientation) is specified.	Do not specify another mode during execution of the Cs contour control command. Before entering another mode, cancel the Cs contour control command.
11	Although servo mode (such as rigid tapping or spindle positioning) is input, another operation mode (Cs contour control, spindle synchronization, or orientation) is specified.	Do not specify another mode during execution of the servo mode command. Before entering another mode, cancel servo mode.

4. CONFIRMATION OF THE OPERATION

START-UP PROCEDURE FOR β iSVSP

B-65325EN/02

No.	Description	Action
12	Although spindle synchronization is input, another operation mode (Cs contour control, servo mode, or orientation) is specified.	Do not specify another mode during execution of the spindle synchronization command. Before entering another mode, cancel the spindle synchronization command.
13	Although orientation specification is input, another operation mode (Cs contour control, servo mode, or synchronization control) is specified.	Do not specify another mode during execution of the orientation command. Before entering another mode, cancel the orientation command.
14	The SFR (forward rotation signal) and SRV (reverse rotation signal) are input at the same time.	Input one of the SFR and SRV signals.
16	Although the parameter not to use the differential speed control function (bit 5 of parameter No. 4000 = 0) is set, DEFMD (differential speed mode command) is input.	Check the setting of the parameter and the differential speed mode command.
17	The parameter settings for the speed detector (bits 2, 1, and 0 of parameter No. 4011) are invalid. There is no speed detector that matches the settings.	Check the setting of the parameter.
18	Although parameter settings are such that there is no position sensor (position control is not to be performed, that is, "bits 3, 2, 1, and 0 of parameter No. 4002 are, respectively, 0, 0, 0, and 0," a position coder-based orientation command has been issued.	Check the setting of the parameter and the input signal.
19	Although magnetic sensor orientation command is input, another operation mode (Cs contour control, servo mode, or spindle synchronization) is specified.	Do not specify another mode during execution of the orientation command. Before entering another mode, cancel the orientation command.
21	The tandem operation command was input in the spindle synchronization control enable state.	Input the tandem operation command when spindle synchronization control is canceled.
22	Spindle synchronization control was specified in the tandem operation enable state.	Specify spindle synchronization control when torque tandem operation is canceled.
23	The tandem operation command is input without the required option.	Torque tandem control requires a CNC software option. Check the option.
24	Although continuous indexing in position coder-based orientation is to be performed, an absolute position command (INCMD = 0) has been issued after incremental operation (INCMD = 1).	Check the INCMD (incremental command). Be sure to perform absolute position command-based orientation before an absolute position command.
26	The parameter settings are such that both spindle switch and three-stage speed range switch are used.	Check the parameter settings and the input signal.
29	Parameter settings are such that the shortest-time orientation function is to be used (bit 6 of parameter No. 4018 is 0 and parameter Nos. 4320 to 4323 are nonzero).	The shortest-time orientation function cannot be used in the β iSVSP. Use a different type of orientation.
30	The magnetic pole has not been detected, but a command is input.	In the magnetic pole undetected state (EPFIXA = 0), the motor cannot be driven even when a command is input. Input a command in the magnetic pole detected state (EPFIXA = 1). When EPFSTR is set to 1, any command is ignored and this error is displayed even in the magnetic pole detected state. After the completion of magnetic pole detection, set EPFSTR to 0.
31	This hardware configuration does not support the use of the spindle FAD function. In this case, the motor is not activated.	Check the CNC model.
32	S0 is not specified in the velocity mode, but the disturbance input function is enabled (bit 7 of parameter No. 4395 is set to 1).	Specify S0 in the velocity mode before enabling the disturbance input function (bit 7 of parameter No. 4395 to 1).

No.	Description	Action
33	This hardware configuration does not support the use of the spindle EGB function. In this case, the motor is not activated.	Check the CNC model.
34	Both spindle FAD function and spindle EGB function are enabled. In this case, the motor is not activated.	These functions cannot be used at the same time. Enable only one of the functions.
35	Spindle Amplifier (SP) ID information cannot be obtained.	Replace the spindle amplifier with one with correct ID information.
36	The submodule SM (SSM) is faulty . 1) The interface signal between the Spindle Amplifier and SSM is disconnected. 2) SSM failure	For the action to be taken for this status error, refer to Section 1.4, "Submodule SM," in Part IV in the FANUC AC SPINDLE MOTOR α i series / FANUC AC SPINDLE MOTOR β i series / FANUC BUILT-IN SPINDLE MOTOR Bi series Parameter Manual (B-65280EN).
37	The current loop setting (No. 4012) has been changed.	Check the setting of parameter No. 4012, and turn the power off, then on again.
38	A parameter related to communication between spindle amplifiers is specified incorrectly. Alternatively, a function unavailable with the torque tandem function is set.	Check the parameters.
39	Although SFR (forward rotation command), SRV (reverse rotation command), or ORCM (orientation command) is input, DSCN (disconnection detection disable signal) is input.	Check the sequence. Do not input DSCN (disconnection detection disable signal) during the input of a command which excites the motor.
43	A setting which does not support the α iCZ sensor (serial) is used.	Check the parameter settings.
44	The spindle amplifier does not support the control period setting.	Check the setting of parameter No. 4012.
45	The setting of the maximum output limit during cutting is not supported.	This is a status error concerning the function for output limit during cutting. This function cannot be used in a system in which this error occurs. Disable this function by setting bit 6 of parameter No. 4011 to 0.
46	The CNC system software does not support spindle synchronous control using a nano-command.	The CNC system software does not support a nano-command. Check the series and edition of the CNC system software.
57	The parameter setting for concurrent use of optimum orientation is used and servo mode reference position return is not correct.	Set non-zero value to the parameter for the servo mode reference position return speed (parameter No. 4074).
59	The setting for the spindle orientation stop position least setting unit 360/32768deg is not correct.	<ul style="list-style-type: none"> The CNC system software does not support the spindle orientation stop position least setting unit 360/32768deg. Check the series and edition of the CNC system software. Concurrent use with the orientation function in spindle synchronization control (bit 6 of parameter No. 4014 is 1) is invalid.
60	The sequence for using spindle phase synchronous control is not correct.	Check the sequence for phase matching of spindle synchronous control. When bit 3 of parameter No. 4006 is set to 1 (not to detect the one-rotation signal automatically), if the spindle phase synchronous command is entered in a state where the one-rotation signal is not detected, this error occurs. Check this point.
63	Spindle DC-link stabilizer during power failure is not supported.	The spindle control software does not support spindle DC-link stabilizer during power failure. Check the series and edition of the spindle control software.

NOTE

*1 When status error 43 is displayed, check the following items. The items to be checked differ depending on the series and edition of the spindle software.

Series 9D80 edition E (edition 05) or edition F (edition 06): Items <1> to <12>

Series 9D80 edition G (edition 07): Items <1> to <9>, <12>, and <13>

Series 9D80 edition H (edition 08): Items <1> to <9>, <13>, and <14>

- (1) For both the motor sensor and spindle sensor, the setting is made to use an α iCZ sensor (serial). (No.4010#2,1,0=0,1,0 and No.4002#3,2,1,0=0,1,1,0)
- (2) Spindle HRV control is not set. (No.4012#7=0)
- (3) The setting is made to use the differential speed control function. (No.4000#5=1)
- (4) The setting is made to use the spindle switch control function. (No.4014#0=1)
- (5) The setting is made so that an alarm related to position feedback is not detected. (No.4007#6=1 or No.4016#5=0)
- (6) The setting is made so that the disconnection of the feedback signal is not detected. (No.4007#5=1)
- (7) The setting is made so that an alarm related to position signal feedback is not detected during thread cutting. (No.4016#5=0)
- (8) The setting is made to use an external one-rotation signal. (No.4004#2=1)
- (9) The setting is made to use a position coder. (No.4002#3,2,1,0=0,0,1,0)
- (10) The setting is made to drive a synchronous spindle motor. (No.4012#6=1)
- (11) The setting is made to use communication between Spindle Amplifiers. (No.4352#7=1 or No.4352#6=1)
- (12) The setting is made to use the Dual Check Safety function.
- (13) The setting is made to use the spindle tandem function. (No.4015#3=1)
- (14) Although the setting is made to use an α iCZ sensor (serial) as the motor sensor, the Dual Check Safety function is enabled.

4.3.4 Observing Data Using the SERVO GUIDE

4.3.4.1 Overview

Using the servo adjustment tool, SERVO GUIDE, enables you to observe internal data for the spindle. This subsection describes the spindle data that can be observed using the SERVO GUIDE. It also presents examples of observed data. Refer to online help for detailed explanations about how to use the SERVO GUIDE.

4.3.4.2 Usable series and editions

- (a) For β iSVSP
 - Series 9D50/G(07) and subsequent editions
 - Series 9D5A/A(01) and subsequent editions
 - Series 9D80/A(01) and subsequent editions
 - Series 9D8A/A(01) and subsequent editions
- (b) For β iSVSPc
 - Series 9D60/C(03) and subsequent editions

4.3.4.3 List of spindle data that can be observed using the SERVO GUIDE

(a) For β iSVSP

The following table lists the spindle data that can be observed using the SERVO GUIDE.

Data type	Description	Remark
SPEED	Motor speed	
INORM	Motor current amplitude	
TCMD	Torque command	
TCMD2	Torque command 2	9D5A/16 and subsequent editions (*4)
VCMD	Motor speed command	
VERR	Speed deviation	
MCMD	Move command for an individual communication cycle	
ERR	Position deviation	9D50/11 and subsequent editions (*1)
ERRC	Position deviation (CNC)	
SYNC	Synchronization error	9D50/11 and subsequent editions (*1)
ORERR	Position error at orientation	
ORSEQ	Orientation sequence data	
PCPOS	Integration of position feedback value	
CSPOS	Integration of position feedback value	
WMDAT	Motion command per position loop	
ERR2	Position deviation 2	
ERR2C	Position deviation 2 (CNC)	9D50/11 and subsequent editions (*1)
SPCMD	Speed command data from the CNC	
SPSPD	Spindle speed	9D50/11 and subsequent editions (*1)
SPCT1	Spindle control signal 1	
SPCT2	Spindle control signal 2	
SPCT3	Spindle control signal 3	
SPST1	Spindle status signal 1	
SPST2	Spindle status signal 2	
SFLG1	Spindle flag 1	9D50/11 and subsequent editions (*1)
SPPOS	Spindle position data	9D50/12 and subsequent editions (*1)
LMDAT	Load meter data	9D50/11 and subsequent editions (*1)
DTRQ	Spindle load torque (Unexpected disturbance torque detection function)	9D50/11 and subsequent editions (*1)
FREQ	Frequency of disturbance torque (Disturbance input function)	9D50/11 and subsequent editions (*1)
GAIN	Gain data (Disturbance input function)	9D50/11 and subsequent editions (*1)
MTTMP	Motor winding temperature	9D50/11 and subsequent editions (*1)
MFADF	Motor sensor feedback incremental data (For tuning amplitude ratio and phase difference compensation)	9D50/11 and subsequent editions (*1)
SFADF	Spindle sensor feedback incremental data (For tuning amplitude ratio and phase difference compensation)	9D50/11 and subsequent editions (*1)
PA1	AD data of A phase of motor sensor	9D50/11 and subsequent editions (*1)
PB1	AD data of B phase of motor sensor	9D50/11 and subsequent editions (*1)
PA2	AD data of A phase of spindle sensor	9D50/11 and subsequent editions (*1)
PB2	AD data of B phase of spindle sensor	9D50/11 and subsequent editions (*1)
VDC	DC link voltage	9D50/11 and subsequent editions (*1)
SFERR	Semi-full error (Dual position feedback)	9D50/11 and subsequent editions (*1)
SMERR	Semi-closed side error (Dual position feedback)	9D50/11 and subsequent editions (*1)
SPACC	Spindle acceleration data	9D50/20 and subsequent editions (*3)

NOTE

- *1 Available with 9D80/01 and subsequent editions, 9D5A/01 and subsequent editions, and 9D8A/01 and subsequent editions
- *2 To observe the data of *1, the SERVO GUIDE Ver. 3.0 or later is required.
- *3 Available with 9D80/04 and subsequent editions, 9D5A/01 and subsequent editions, and 9D8A/01 and subsequent editions. To observe this data, the SERVO GUIDE Ver. 4.10 or later is required.
- *4 Available with 9D8A/03 and subsequent editions. To observe this data, the SERVO GUIDE Ver. 8.10 or later is required.

(b) For β iSVSPc

The following table lists the spindle data that can be observed using the SERVO GUIDE.

Data type	Description	Remark
SPEED	Motor speed	
INORM	Motor current amplitude	
TCMD	Torque command	
VCMD	Motor speed command	
VERR	Speed deviation	
MCMD	Move command for an individual communication cycle	
ERR	Position deviation	
ERRC	Position deviation (CNC)	
SYNC	Synchronization error	
ORERR	Position error at orientation	
ORSEQ	Orientation sequence data	
PCPOS	Integration of position feedback value	
WMDAT	Motion command per position loop	
ERR2	Position deviation 2	
ERR2C	Position deviation 2 (CNC)	
SPCMD	Speed command data from the CNC	
SPSPD	Spindle speed	
SPCT1	Spindle control signal 1	
SPCT2	Spindle control signal 2	
SPCT3	Spindle control signal 3	
SPST1	Spindle status signal 1	
SPST2	Spindle status signal 2	
SFLG1	Spindle flag 1	
SPPOS	Spindle position data	
LMDAT	Load meter data	
MTTMP	Motor winding temperature	
VDC	DC link voltage	

4.3.4.4 About the spindle control and spindle status signals

As stated in the previous item, the SERVO GUIDE can be used to observe the PMC signals (spindle control signals 1, 2, and 3 and spindle status signals 1 and 2) used by the spindle.

Listed below is the data configuration for spindle control signals 1 and 2 and spindle status signals 1 and 2. Refer to Chapter 3, "Input/Output Signals (CNC ↔ PMC)" of "FANUC AC SPINDLE MOTOR α i series / FANUC AC SPINDLE MOTOR β i series / FANUC BUILT-IN SPINDLE MOTOR B i series Parameter Manual (B-65280EN)" for explanations about each signal.

(a) Spindle control signal 1 (SPCT1)

#15	#14	#13	#12	#11	#10	#9	#8
RCH	RSL	INTG	SOCN	MCFN	SPSL	*ESP	ARST
#7	#6	#5	#4	#3	#2	#1	#0
MRDY	ORCM	SFR	SRV	CTH1	CTH2	TLMH	TLML

(b) Spindle control signal 2 (SPCT2)

#15	#14	#13	#12	#11	#10	#9	#8
			DSCN	SORSL	MPOF		
#7	#6	#5	#4	#3	#2	#1	#0
RCHHG	MFNHG	INCMD	OVR		NRRO	ROTA	INDX

(c) Spindle control signal 3 (SPCT3)

#15	#14	#13	#12	#11	#10	#9	#8
#7	#6	#5	#4	#3	#2	#1	#0

(d) Spindle status signal 1 (SPST1)

#15	#14	#13	#12	#11	#10	#9	#8
				RCFN	RCHP	CFIN	CHP
#7	#6	#5	#4	#3	#2	#1	#0
ORAR	TLM	LDT2	LDT1	SAR	SDT	SST	ALM

(e) Spindle status signal 2 (SPST2)

#15	#14	#13	#12	#11	#10	#9	#8
#7	#6	#5	#4	#3	#2	#1	#0
			EXOF	SOREN		INCST	PC1DT

4.3.4.5 Example of observing data

The following figure shows an example of data (synchronization error and motor speed at rigid tapping) observed using the SERVO GUIDE.

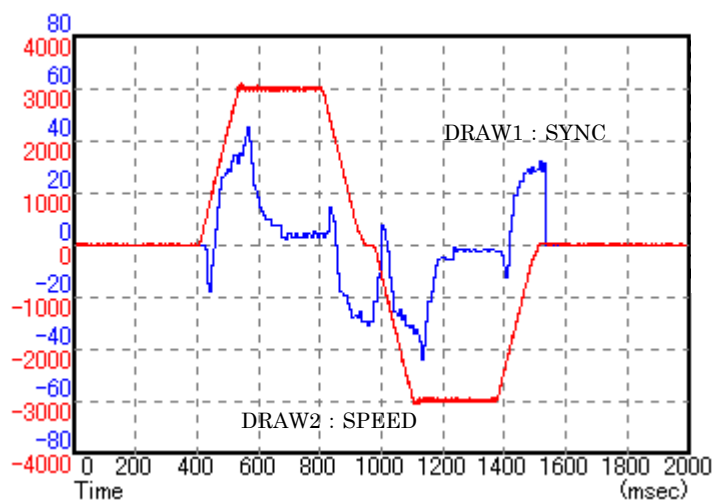

DRAW1 : SYNC (synchronization error) ^(*)

DRAW2 : SPEED (motor speed)

*1 The synchronization error can be observed in the servo axis.

4.3.5 Spindle Check Board

When connecting the spindle check board, you can:

- <1> Observe signal waveforms.
- <2> Observe internal data.
- <3> Check spindle parameter values.

4.3.5.1 Spindle check board specifications

Spindle check board specifications is bellow.

Table 4.3.5.1 Spindle check board specifications

Specification	Drawing No. of printed circuit board	Applicable unit
A06B-6078-H001	A20B-2001-0830	β iSVSP

4.3.5.2 Spindle check board connection

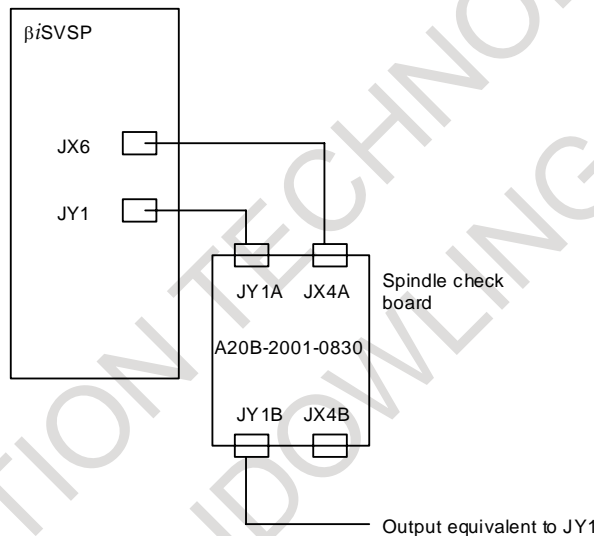

4.3.5.3 Check terminal output signals

(1) β iSVSP

Check terminal	Signal name	Check terminal	Signal name
LM	Load meter signal	PA1	A phase sine wave signal 1
SM	Speedometer signal	PB1	B phase sine wave signal 1
CH1	Analog output for internal data observation (Phase U current: IU)	PS1	Z phase sine wave signal 1
CH2	Analog output for internal data observation (Motor speed TSA: 1638 min ⁻¹ /V)	PA2	Disuse
CH1D	Output for internal data bit observation	PB2	Disuse
CH2D	Output for internal data bit observation	PS2	Disuse
VRM	Disuse	PA3	Disuse
LSA1	Disuse	PB3	Disuse
EXTSC1	External one-rotation signal (MAIN)	PA4	Disuse
LSA2	Disuse	PB4	Disuse
EXTSC2	Disuse	OVR2	Analog override command
PAD	Disuse	15V	Disuse

Check terminal	Signal name	Check terminal	Signal name
PBD	Disuse	5V	+5 VDC power check
PSD	Disuse	-15V	Disuse
		GND	0V

(2) β iSVSP and β iSVSPc (For α iM, α iMZ sensor-less)

Check terminal	Signal name	Check terminal	Signal name
LM	Speedometer signal (This can be switched to the load meter signal by parameter setting.)	PA1	Disuse
SM	Disuse	PB1	Disuse
CH1	Analog output for internal data observation (Phase U current: IU)	PS1	Disuse
CH2	Analog output for internal data observation (Estimated motor speed : 1638 min ⁻¹ /V)	PA2	Disuse
CH1D	Output for internal data bit observation	PB2	Disuse
CH2D	Output for internal data bit observation	PS2	Disuse
VRM	Disuse	PA3	Disuse
LSA1	Disuse	PB3	Disuse
EXTSC1	Disuse	PA4	Disuse
LSA2	Disuse	PB4	Disuse
EXTSC2	Disuse	OVR2	Analog override command
PAD	Disuse	15V	Disuse
PBD	Disuse	5V	+5 VDC power check
PSD	Disuse	-15V	Disuse
		GND	0V

Check terminal arrangement

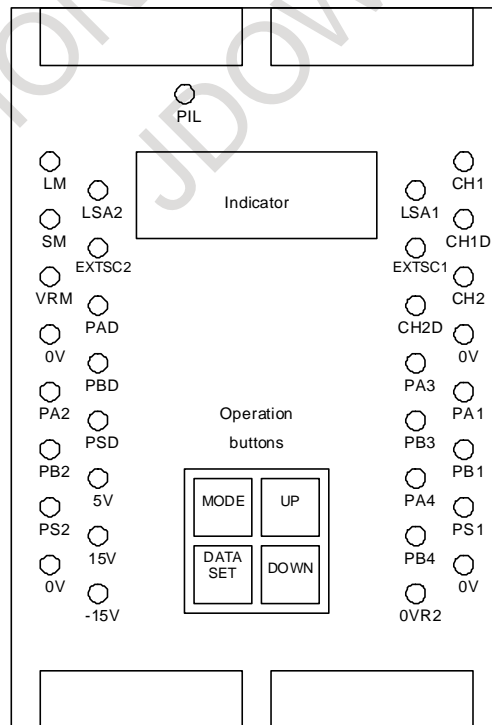

4.3.6 Checking the Feedback Signal Waveform

The measurement locations and the method for attaching connectors vary depending on the configuration of the detector. Check the waveform while seeing Table 4.3.6. The check terminals are on the check board.

Table 4.3.4(a) Signals input to the β iSVSP and corresponding check terminals on the check board

Check terminal name	Spindle Amplifier input signal (connector name-pin No.)	Main sensors	Remarks
PA1 PB1	JYA2-pin5,6 JYA2-pin7,8	α i M, α i MZ, and α i BZ sensors Analog α i CZ sensor	
PA2 PB2	JYA4-pin5,6 JYA4-pin7,8	α i BZ sensor Analog α i CZ sensor α position coder S (1024 λ)	
PS1	JYA2-pin1,2	α i MZ and α i BZ sensors (one-rotation signal) Analog α i CZ sensor (one-rotation signal)	
PS2	JYA4-pin1,2	α i BZ sensor (one-rotation signal) Analog α i CZ sensor (one-rotation signal)	
EXTSC1	JYA3-pin15	Proximity switch (external one-rotation signal)	

For the α i position coder and α position coder S (one-rotation signal), observe the Spindle Amplifier input signal directly, using the servo check pin board A06B-6071-K290.

4.3.6.1 α i M sensor, α i MZ sensor, and α i BZ sensor

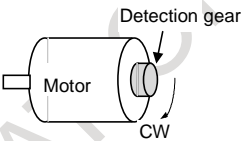
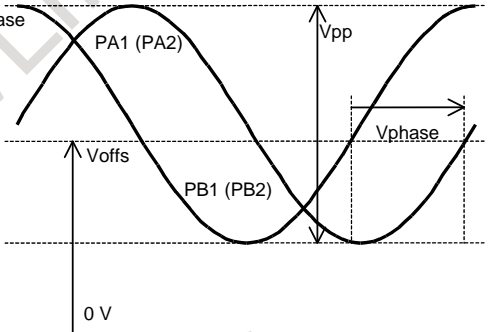
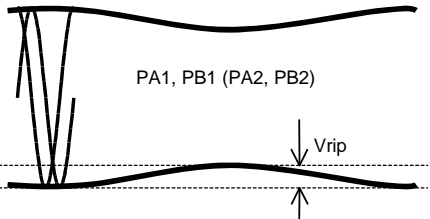
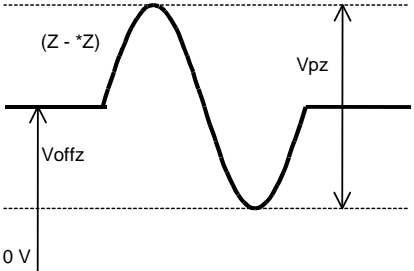
Measurement location	Measurement condition	Sample waveform
PA1, PB1	<p>The speed must be 1500 min⁻¹ or less.</p> <p>Rotation direction: CW</p> 	<p>Waveforms of phase A and phase B</p>  <p>Ripples of phase A and phase B</p>  <p>For αi MZ and αi BZ sensors only</p> <p>Waveform of phase Z</p> 

Measurement item	Specification	Measurement method	Adjustment method
Vpp	0.5 to 1.2 Vp-p	Use the DC range of a digital voltmeter.	Normally, only the α i M and α i MZ sensors need not be adjusted. For Voffs and Voffz, only level check is possible, but adjustment is not possible.
Voffs, Voffsz	2.5 V \pm 100 mV		
Vphase	90 \pm 3°		
Vrip	< 70 mV		
Vpz	> 0.5 V		

4.3.6.2 α i CZ sensor

For how to check the serial output α iCZ sensor signals, refer to the technical report of the relevant sensor.

4.3.6.3 α position coder S

Measurement location	Measurement condition	Sample waveform
PA2, PB2	CW rotation direction as viewed from the flange	<p>Waveforms of phase A and phase B</p> <p>Waveform of phase Z (Z-*Z)</p>

Measurement item	Specification	Measurement method	Adjustment method
Vpp	0.8 to 1.2 Vp-p	Use the DC range of a digital voltmeter.	Only level check is possible, but adjustment is not possible.
Voffs, Voffsz	2.5 V \pm 100 mV		
Vphase	90 \pm 5°		

4.4 β iSVSP SERVO UNIT

4.4.1 Checking the STATUS 2 Indicator

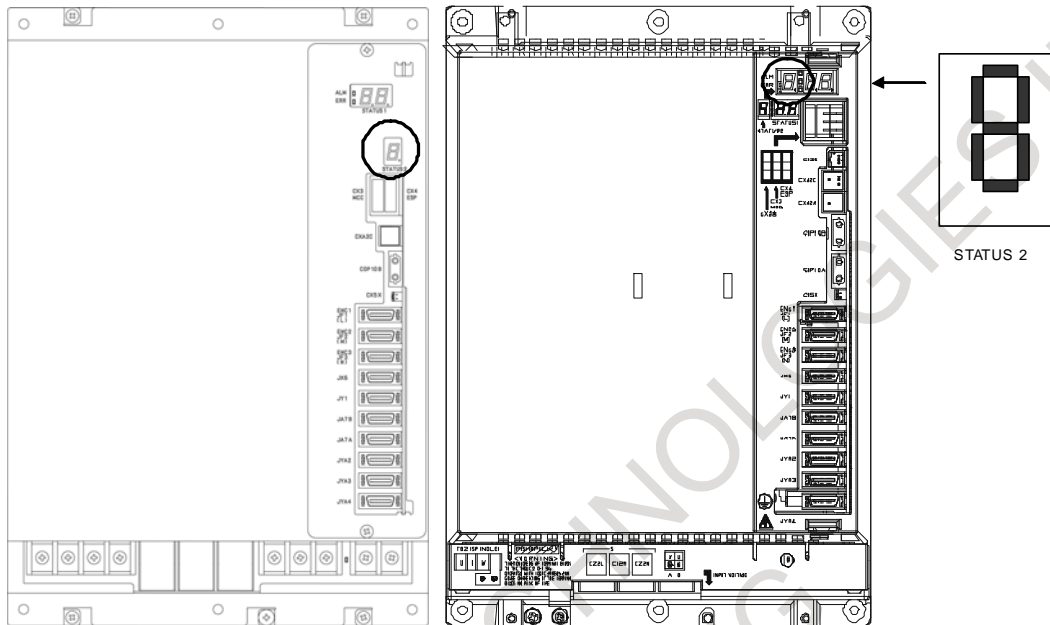

STATUS display	Description
	The STATUS LED is off. The control power is not supplied, a cable is faulty, or the control power circuit is defective.
	The control power is short-circuited ("- " blinks). A cable is faulty.
	The system is waiting for the READY signal from the CNC.
	Ready status The servo motor is in the activation state.

4.4.2 VRDY-OFF Alarm Indicated on the CNC Screen

When the VRDY-OFF alarm is indicated on the CNC, check the items listed below. In addition, VRDY-OFF can occur also for reasons other than listed below. If the following items turn out to have not caused VRDY-OFF, check diagnosis information No. 358 (V ready-off information) on the diagnosis screen and report it to FANUC.

- (1) Emergency stop signal (ESP)
Has the emergency stop signal (connector: CX4) applied to the β iSVSP been released? Alternatively, is the signal connected correctly?
- (2) MCON signal
Hasn't setting up the axis detach function disabled the transmission of the ready command signal MCON from the CNC to the β iSVSP?
- (3) β iSVSP control printed-circuit board
The β iSVSP control printed-circuit board may be poorly installed or faulty. Be sure to push the faceplate as far as it will go. If the problem persists, replace the control printed-circuit board.

Checking diagnosis information (DGN) No. 358 makes it possible to analyze the cause of the VRDY-OFF alarm.

* Some CNCs such as Series 16i/18i/21i-A do not support this function.

Diagnosis **358** V ready-off information

Convert the displayed value to binary form, and check bits 5 to 14 of the resulting binary number.

When the servo amplifier starts working, these bits become 1 sequentially, starting at bit 5. When the servo amplifier has started normally, all of bits 5 to 14 become 1.

Check bits 5 to 14 sequentially, starting at the lowest-order bit. The first lowest bit that is not 0 corresponds to the processing that caused the V ready-off alarm.

#15	#14	#13	#12	#11	#10	#9	#8
	SRDY	DRDY	INTL	RLY	CRDY	MCOFF	MCONA
#7	#6	#5	#4	#3	#2	#1	#0
MCONS	*ESP	HRDY					

#06(*ESP) Emergency stop signal

#07,#08,#09 MCON signal (CNC → amplifier → converter)

#10(CRDY) Converter preparation completed signal

#11(RLY) Relay signal (DB relay energized)

#12(INTL) Interlock signal (DB relay de-energized)

#13(DRDY) Amplifier preparation completed signal

The following table lists diagnosis No. 358 values and main causes of problems. Do not insert or remove any connector when the power is on.

Diagnosis No. 358 value	Problem	Check item
417	The emergency stop state persists.	(1) Check whether the emergency stop signal input to CX4 of β iSVSP has been released. (2) Check whether there is no problem with the connection or cable for communication between the amplifiers. (3) Replace the servo amplifier.
993	The β iSVSP (common power supply) preparation completed signal (CRDY) is not output.	(1) Check whether there is no problem with the connection or cable for communication (CXA2A/B) between the amplifiers. (2) Check whether the input power is supplied. (3) Check whether power is supplied to the operation coil of the magnetic contactor. Check whether there is no problem with connection of CX3 of the common power supply. (4) Replace the servo amplifier.
4065	The interlock signal is not input.	Replace the servo amplifier.
225	-	Replace the servo amplifier.
481	-	Replace the servo amplifier.
2017	-	Replace the servo amplifier.
8161	-	Replace the servo amplifier.
97	-	Check whether the axis detach function is set.

4.4.3 Method for Observing Motor Current

This subsection explains how to observe the current that flows through the servo motor.

(1) Method of using the SERVO GUIDE

Refer to online help for information about how to connect to and use the servo adjustment tool "SERVO GUIDE" and applicable CNC systems.

- Setting

Select an axis to be subjected to measurement in graph window channel setting. Also select IR and IS under Kind. Under Coef (conversion coefficient), set the maximum allowable current (Ap) for the amplifier in use.

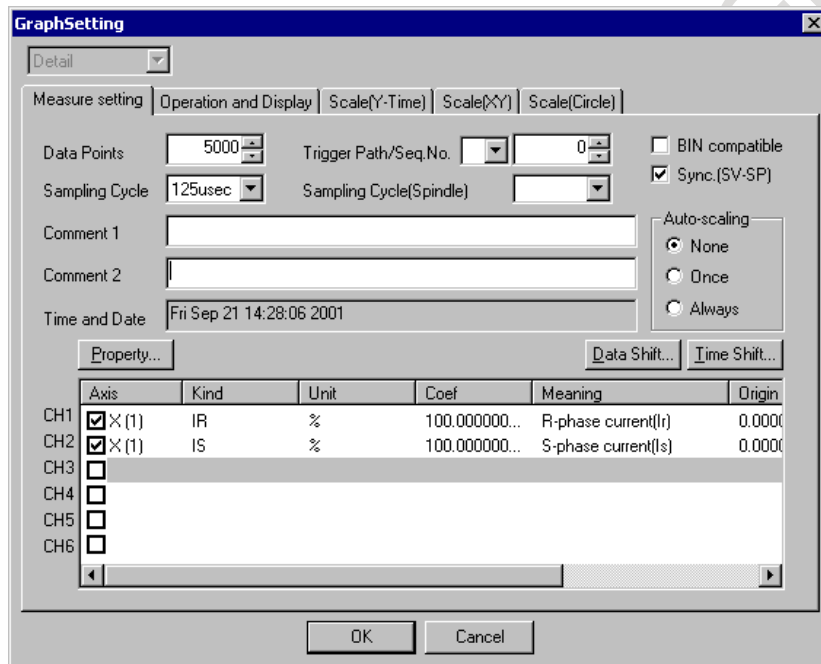

NOTE

- 1 In servo software except for series 9096, the motor current sampling cycle depends on the current control cycle.
- 2 Servo software series 9096 supports setting of a motor current sampling period of 1 ms only.

- Display

Select the XTYT mode from the graph window mode (M) menu to display waveforms.

(2) Method of using the servo check board

For details on how to connect and use the servo check board, refer to the following:

Appendix I in the "FANUC AC SERVO MOTOR α i series/FANUC AC SERVO MOTOR β i series/FANUC LINEAR MOTOR LiS series/FANUC SYNCHRONOUS BUILT-IN SERVO MOTOR DiS series Parameter Manual (B-65270EN)."

- Required units

- Servo check board
A06B-6057-H630
- Oscilloscope

- Setting CNC setting

Parameter setting for servo software series 90B0

Output channel	Data number $\boxed{5}$		Data number $\boxed{6}$	
FS16i/18i/21i/0i/PMi	No.2115	No.2151	No.2152	No.2153
Measurement axis/ current phase	IR		IS	
L-axis ^(Note 1)	370	0	402	0
M-axis ^(Note 1)	2418	0	2450	0

Parameter setting for servo software series 9096

Output channel	Data number $\boxed{5}$	Data number $\boxed{6}$
FS16i/18i/21i/0i/PMi	No.2115	No.2115
Measurement axis/ current phase	IR	IS
L-axis ^(Note 1)	370	402
M-axis ^(Note 1)	1010	1042

When series 9096 is used, if no axis is paired with the measurement axis ^(Note 2), IR and IS cannot be observed simultaneously.

NOTE

- 1 The L-axis is an axis identified with an odd number set in parameter No. 1023. The M-axis is an axis identified with an even number set in parameter No. 1023.
- 2 The axis specified as 2n-1 in parameter No. 1023 and the axis specified as 2n will be in a pair.

Setting the output period of motor current data (for the 90B0 series only)

Output period	Parameter No. 1746 / Bit 7 of parameter No. 2206
Velocity loop period	0 (default)
Current loop period	1 ^(Note 3)

NOTE

- 3 If the current loop period is set up as the motor current data output period, selecting data number $\boxed{0}$, $\boxed{1}$, $\boxed{2}$, or $\boxed{4}$ disables the output of signals (such as a velocity command) to channels. To observe the motor current and other signals (such as a velocity command), specify the output period as 1 ms.
- 4 For the servo software series 9096, the output period of the motor current is only 1 ms. The current loop period cannot be used for output.

- Setting up the check board

- Set the AXIS digit of the LED display with an axis number from $\boxed{1}$ to $\boxed{8}$ specified in parameter No. 1023.
- Set the DATA digit of the LED display with a data number from $\boxed{5}$ to $\boxed{6}$.

- Method for observing the motor current

The voltage corresponding to the motor current is output to a channel for which $\boxed{5}$ or $\boxed{6}$ is set as the data number on the servo check board.

The waveform of the motor current can be observed by measuring the voltage mentioned above with an oscilloscope.

The following table lists the relationships between the observed voltage and the motor current.

Maximum amplifier current	Motor current/ observed voltage [A/V]
20Ap	5
40Ap	10

4. CONFIRMATION OF THE OPERATION

Maximum amplifier current	Motor current/ observed voltage [A/V]
80Ap	20

Maximum amplifier current

βi SVSP	L-axis	M-axis	N-axis
βi SVSP20/20-*	20 Ap	20Ap	
βi SVSP40/40-*	40Ap	40Ap	
βi SVSP80/80-*	80Ap	80Ap	
βi SVSP20/20/20-*	20Ap	20Ap	20Ap
βi SVSP20/20/40-*	20Ap	20Ap	40Ap
βi SVSP40/40/40-*	40Ap	40Ap	40Ap
βi SVSP40/40/80-*	40Ap	40Ap	80Ap
βi SVSP80/80/80-*	80Ap	80Ap	80Ap

For the axis 20Ap, for example, the motor current is 5A (actual value rather than effective value) if the observed voltage is 1V.

IV. TROUBLESHOOTING FOR βi SVSP

JR AUTOMATION TECHNOLOGIES INC*
JDOWLING

JR AUTOMATION TECHNOLOGIES INC*
JDOWLING

1 OVERVIEW

This part describes the troubleshooting procedure. Read the section related to your current trouble to locate it and take an appropriate action.

First, check the alarm number (indicated by the CNC) and the STATUS1 and STATUS2 indications in Chapter 2 to find the cause.

Then, take an appropriate action according to the corresponding description in Chapter 3.

JR AUTOMATION TECHNOLOGIES INC*
JDOWLING

2 ALARM NUMBERS AND BRIEF DESCRIPTIONS

2.1 For Series 0i/0i Mate-D

2.1.1 Servo Alarm

Alarm No.	SV	Description	Reference item
SV0361		Pulsecoder phase error (built-in)	3.3.7 (1)
SV0364		Soft phase alarm (built-in)	3.3.7 (1)
SV0365		LED error (built-in)	3.3.7 (1)
SV0366		Pulse error (built-in)	3.3.7 (1)
SV0367		Count error (built-in)	3.3.7 (1)
SV0368		Serial data error (built-in)	3.3.7 (3)
SV0369		Data transfer error (built-in)	3.3.7 (3)
SV0380		LED error (separate)	3.3.7 (2)
SV0381		Pulsecoder phase error (separate)	3.3.7 (2)
SV0382		Count error (separate)	3.3.7 (2)
SV0383		Pulse error (separate)	3.3.7 (2)
SV0384		Soft phase alarm (separate)	3.3.7 (2)
SV0385		Serial data error (separate)	3.3.7 (3)
SV0386		Data transfer error (separate)	3.3.7 (3)
SV0387		Sensor error (separate)	3.3.7 (2)
SV0417		Invalid parameter setting	3.3.6
SV0421		Excessive semi-full error	3.3.8
SV0430		Servo motor overheat	3.3.5
SV0432		Converter: control power supply under voltage	3.1.8
SV0433		Converter: DC link under voltage	3.1.5
SV0436		Soft thermal (OVC)	3.3.3
SV0438	b	Inverter: motor current alarm (L axis)	3.2.8
SV0438	C	Inverter: motor current alarm (M axis)	3.2.8
SV0438	d	Inverter: motor current alarm (N axis)	3.2.8
SV0439		Converter: DC link overvoltage	3.1.2
SV0440		Converter: Excessive deceleration power	
SV0441		Current offset error	3.3.8
SV0444	1	Inverter: Internal cooling fan stopped	3.2.1
SV0445		Soft disconnection alarm	3.3.4
SV0447		Hard disconnection alarm (separate)	3.3.4
SV0448		Feedback mismatch alarm	3.3.4
SV0449	8.	Inverter: IPM alarm (L axis)	3.2.6
SV0449	9.	Inverter: IPM alarm (M axis)	3.2.6
SV0449	A.	Inverter: IPM alarm (N axis)	3.2.6
SV0453		α Pulsecoder: soft disconnection	3.3.4
SV0601		Inverter: cooling fan stopped of the radiator	
SV0603	8.	Inverter: IPM alarm (L axis) (OH)	3.2.7
SV0603	9.	Inverter: IPM alarm (M axis) (OH)	3.2.7
SV0603	A.	Inverter: IPM alarm (N axis) (OH)	3.2.7
SV0604	P	Communication error between amplifier and module	3.2.5

2.1.2 Spindle Alarm

Alarm No.	SP	Description	Reference item
SP9001	01	Motor overheat	3.4.1
SP9002	02	Excessive speed deviation	3.4.2
SP9003	03	DC link fuse broken	3.4.3
SP9004	04	PS improper input power	3.1.1
SP9006	06	Temperature sensor disconnected	3.4.4
SP9007	07	Over speed	3.4.5
SP9009	09	Main circuit overheat	3.4.6
SP9010	10	Input power supply low voltage	3.4.7
SP9011	11	PS: DC link overvoltage	3.1.2
SP9012	12	DC link overcurrent	3.4.8
SP12xx	13	CPU internal data memory error	3.4.9
SP9014	14	Software series mismatch	3.4.10
SP9015	15	Spindle switching/speed range switching alarm	3.4.11
SP9016	16	RAM error	3.4.12
SP9017	17	ID number parity error	3.4.13
SP12xx	18	Program ROM sum check error	3.4.14
SP12xx	19	Excessive offset of the phase U current detection	3.4.15
SP12xx	20	Excessive offset of the phase V current detection	3.4.15
SP9021	21	Position sensor polarity setting incorrect	3.4.16
SP9022	22	SP: Over current	3.4.17
SP12xx	24	Serial transfer data error	3.4.18
SP9027	27	Position coder signal disconnected	3.4.19
SP9029	29	Overload	3.4.20
SP9030	30	PS: Input overcurrent	3.1.3
SP9031	31	Motor lock	3.4.21
SP9032	32	Serial LSI RAM error	3.4.22
SP9033	33	PS: Precharge failure	3.1.4
SP9034	34	Illegal parameter	3.4.23
SP9035	35	Excessive gear ratio setting data	3.4.24
SP9036	36	Error counter overflow	3.4.25
SP9037	37	Speed detection parameter error	3.4.26
SP9041	41	PC one-rotation signal detection error	3.4.27
SP9042	42	PC one-rotation signal undetected	3.4.28
SP9043	43	Position coder signal for differential speed is disconnected	3.4.29
SP9046	46	PC one-rotation signal detection error during threading	3.4.30
SP9047	47	Position coder signal error	3.4.31
SP9049	49	Excessive differential speed	3.4.32
SP9050	50	Excessive spindle speed in spindle synchronization	3.4.33
SP9051	51	PS: DC link low voltage	3.1.5
SP9052	52	ITP signal error I	3.4.34
SP9053	53	ITP signal error II	3.4.34
SP9054	54	Over current	3.4.35
SP9055	55	Illegal switching of power line	3.4.36
SP9056	56	Internal cooling fan stopped	3.4.37
SP9058	58	PS: main circuit overload	3.1.6
SP9059	59	PS: Internal cooling fan stopped	3.1.7
SP9061	61	Excessive dual position FB semi-full error	3.4.38
SP9066	66	Communication error between spindle amplifiers	3.4.39
SP9067	67	FSC/EGB command error	3.4.40
SP9068	68	Invalid spindle parameter setting	3.4.41
SP9069	69	Safety speed exceeded	3.4.42
SP9070	70	Axis data error	3.4.43

2. ALARM NUMBERS AND BRIEF DESCRIPTIONS

TROUBLESHOOTING FOR β iSVSP

B-65325EN/02

Alarm No.	SP	Description	Reference item
SP9071	71	Safety parameter error	3.4.44
SP9072	72	Mismatch result of motor speed check	3.4.45
SP9073	73	Motor sensor disconnected	3.4.46
SP9074	74	CPU test alarm	3.4.47
SP9075	75	CRC test alarm	3.4.48
SP9076	76	Safety function not executed	3.4.49
SP9077	77	Mismatch result of axis number check	3.4.50
SP9078	78	Mismatch result of safety parameter check	3.4.51
SP9079	79	Initial test error	3.4.52
SP9081	81	Motor sensor one-rotation signal detection error	3.4.53
SP9082	82	Motor sensor one-rotation signal not detected	3.4.54
SP9083	83	Motor sensor signal error	3.4.55
SP9084	84	Spindle sensor disconnected	3.4.56
SP9085	85	Spindle sensor one-rotation signal detection error	3.4.57
SP9086	86	Spindle sensor one-rotation signal not detected	3.4.58
SP9087	87	Spindle sensor signal error	3.4.59
SP9088	88	Radiator cooling fan stopped	3.4.60
SP9092	92	Excessive speed (against velocity command)	3.4.61
SP12xx	A	Program ROM error	3.4.62
SP12xx	A1	Program ROM error	3.4.62
SP12xx	A2	Program ROM error	3.4.62
SP9110	b0	Communication error between amplifiers	3.4.63
SP9111	b1	PS: control power low voltage	3.1.8
SP9120	C0	Communication data error	3.4.64
SP9121	C1	Communication data error	3.4.64
SP9122	C2	Communication data error	3.4.64
SP9123	C3	Spindle switching circuit error	3.4.65
SP9128	C8	Spindle synchronous control: Excessive speed deviation	3.4.66
SP9129	C9	Spindle synchronous control: Excessive position deviation	3.4.67
SP9131	d1	Spindle tuning function alarm	3.4.68
SP9132	d2	Serial sensor: Data error	3.4.69
SP9133	d3	Serial sensor: Data transfer error	3.4.70
SP9134	d4	Serial sensor: Soft phase alarm	3.4.71
SP9136	d6	Mismatch result of safety speed zero check (SP)	3.4.72
SP9137	d7	SP: Device communication error	3.4.73
SP9138	d8	Current limit level setting error	3.4.74
SP9139	d9	Serial sensor: Pulse miss	3.4.75
SP9140	E0	Serial sensor: Count miss	3.4.76
SP9141	E1	Serial sensor: One-rotation signal undetected	3.4.77
SP9142	E2	Serial sensor error	3.4.78
SP9158	F8	Mismatch result of mode (DCS)	3.4.79
SP9166	G6 ^{*1}	Spindle synchronous control for guide bush : Excessive synchronous error	3.4.80
SP9167	G7 ^{*1}	Failure of SP control sequence	3.4.81

(*1) The seven-segment LED indicates "F9".

2.2 For Series 0i/0i Mate-B,C

2.2.1 Servo Alarm

Servo alarm	Spindle alarm	STATUS1 Spindle unit	STATUS2 Servo unit	Description	Reference item
361				Pulsecoder phase error (built-in)	3.3.7 (1)
364				Soft phase alarm (built-in)	3.3.7 (1)
365				LED error (built-in)	3.3.7 (1)
366				Pulse error (built-in)	3.3.7 (1)
367				Count error (built-in)	3.3.7 (1)
368				Serial data error (built-in)	3.3.7 (3)
369				Data transfer error (built-in)	3.3.7 (3)
380				LED error (separate)	3.3.7 (2)
381				Pulsecoder phase error (separate)	3.3.7 (2)
382				Count error (separate)	3.3.7 (2)
383				Pulse error (separate)	3.3.7 (2)
384				Soft phase alarm (separate)	3.3.7 (2)
385				Serial data error (separate)	3.3.7 (3)
386				Data transfer error (separate)	3.3.7 (3)
387				Sensor error (separate)	3.3.7 (2)
417				Invalid parameter setting	3.3.6
421				Excessive semi-full error	3.3.8
430				Servo motor overheat	3.3.5
431	9058	58		Converter: main circuit overload	3.1.6
432	9111	b1		Converter: control power supply undervoltage	3.1.8
433	9051	51		Converter: DC link undervoltage	3.1.5
434			2	Inverter: control power supply low voltage	3.2.2
435			5	Inverter: DC link undervoltage	3.2.3
436				Soft thermal (OVC)	3.3.3
437	9030	30		Overcurrent in the converter input circuit	3.1.3
438			b	Inverter: motor current alarm (L axis)	3.2.8
438			C	Inverter: motor current alarm (M axis)	3.2.8
438			d	Inverter: motor current alarm (N axis)	3.2.8
439	9011	11		Converter: DC link overvoltage	3.1.2
441				Current offset error	3.3.8
442	9033	33		Converter: DC link precharge failure	3.1.4
445				Soft disconnection alarm	3.3.4
447				Hard disconnection alarm (separate)	3.3.4
448				Feedback mismatch alarm	3.3.4
449			8.	Inverter: IPM alarm (L axis)	3.2.6
449			9.	Inverter: IPM alarm (M axis)	3.2.6
449			A.	Inverter: IPM alarm (N axis)	3.2.6
453				α Pulsecoder: soft disconnection	3.3.4
601			F	Inverter: cooling fan stopped of the radiator	
602			6	Inverter: overheat	3.2.4
603			8.	Inverter: IPM alarm (L axis) (OH)	3.2.7
603			9.	Inverter: IPM alarm (M axis) (OH)	3.2.7
603			A.	Inverter: IPM alarm (N axis) (OH)	3.2.7
604			P	Communication error between amplifier and module	3.2.5
607	9004	04		Open phase in the converter main power supply	3.1.1

2.2.2 Spindle Alarm

Servo alarm	Spindle alarm	STATUS1 Spindle unit	STATUS2 Servo unit	Description	Reference item
	9001	01		Motor overheat	3.4.1
	9002	02		Excessive speed deviation	3.4.2
	9003	03		DC link fuse broken	3.4.3
607	9004	04		PS improper input power	3.1.1
	9006	06		Temperature sensor disconnected	3.4.4
	9007	07		Over speed	3.4.5
	9009	09		Main circuit overheat	3.4.6
	9010	10		Input power supply low voltage	3.4.7
439	9011	11		PS: DC link overvoltage	3.1.2
	9012	12		DC link overcurrent	3.4.8
	9013	13		CPU internal data memory error	3.4.9
	9014	14		Software series mismatch	3.4.10
	9015	15		Spindle switching/speed range switching alarm	3.4.11
	9016	16		RAM error	3.4.12
	9017	17		ID number parity error	3.4.13
	750	18		Program ROM sum check error	3.4.14
	750	19		Excessive offset of the phase U current detection	3.4.15
	750	20		Excessive offset of the phase V current detection	3.4.15
	9021	21		Position sensor polarity setting incorrect	3.4.16
	9022	22		SP: Over current	3.4.17
	749	24		Serial transfer data error	3.4.18
	9027	27		Position coder signal disconnected	3.4.19
	9029	29		Overload	3.4.20
437	9030	30		PS: Input overcurrent	3.1.3
	9031	31		Motor lock	3.4.21
	9032	32		Serial LSI RAM error	3.4.22
442	9033	33		PS: Precharge failure	3.1.4
	9034	34		Illegal parameter	3.4.23
	9035	35		Excessive gear ratio setting data	3.4.24
	9036	36		Error counter overflow	3.4.25
	9037	37		Speed detection parameter error	3.4.26
	9041	41		PC one-rotation signal detection error	3.4.27
	9042	42		PC one-rotation signal undetected	3.4.28
	9043	43		Position coder signal for differential speed is disconnected	3.4.29
	9046	46		PC one-rotation signal detection error during threading	3.4.30
	9047	47		Position coder signal error	3.4.31
	9049	49		Excessive differential speed	3.4.32
	9050	50		Excessive spindle speed in spindle synchronization	3.4.33
433	9051	51		PS: DC link low voltage	3.1.5
	9052	52		ITP signal error I	3.4.34
	9053	53		ITP signal error II	3.4.34
	9054	54		Over current	3.4.35
	9055	55		Illegal switching of power line	3.4.36
	9056	56		Internal cooling fan stopped	3.4.37
431	9058	58		PS: Main circuit overload	3.1.6
	9059	59		PS: Internal cooling fan stopped	3.1.7
	9061	61		Excessive dual position FB semi-full error	3.4.38
	9067	67		FSC/EGB command error	3.4.40

Servo alarm	Spindle alarm	STATUS1 Spindle unit	STATUS2 Servo unit	Description	Reference item
	9068	68		Invalid spindle parameter setting	3.4.41
	9073	73		Motor sensor disconnected	3.4.46
	9074	74		CPU test alarm	3.4.47
	9075	75		CRC test alarm	3.4.48
	9079	79		Initial test error	3.4.52
	9081	81		Motor sensor one-rotation signal detection error	3.4.53
	9082	82		Motor sensor one-rotation signal not detected	3.4.54
	9083	83		Motor sensor signal error	3.4.55
	9084	84		Spindle sensor disconnected	3.4.56
	9085	85		Spindle sensor one-rotation signal detection error	3.4.57
	9086	86		Spindle sensor one-rotation signal not detected	3.4.58
	9087	87		Spindle sensor signal error	3.4.59
	9088	88		Radiator cooling fan stopped	3.4.60
	9092	92		Excessive speed (against velocity command)	3.4.61
	749	A		Program ROM error	3.4.62
	749	A1		Program ROM error	3.4.62
	749	A2		Program ROM error	3.4.62
432	9111	b1		PS: control power supply low voltage	3.1.8
	9120	C0		Communication data error	3.4.64
	9121	C1		Communication data error	3.4.64
	9122	C2		Communication data error	3.4.64
	9123	C3		Spindle switching circuit error	3.4.65
	9128	C8		Spindle synchronous control: Excessive speed deviation	3.4.66
	9129	C9		Spindle synchronous control: Excessive position deviation	3.4.67
	9131	d1		Spindle tuning function alarm	3.4.68
	9132	d2		Serial sensor: Data error	3.4.69
	9133	d3		Serial sensor: Data transfer error	3.4.70
	9134	d4		Serial sensor: Soft phase alarm	3.4.71
	9137	d7		SP: Device communication error	3.4.73
	9138	d8		Current limit level setting error	3.4.74
	9139	d9		Serial sensor: Pulse miss	3.4.75
	9140	E0		Serial sensor: Count miss	3.4.76
	9141	E1		Serial sensor: One-rotation signal undetected	3.4.77
	9142	E2		Serial sensor error	3.4.78
	9167	G7 ¹		Failure of SP control sequence	3.4.81

(*) The letter "n" in an alarm number indicates an axis number.

(*1) The seven-segment LED indicates "F9".

3 TROUBLESHOOTING AND ACTION

3.1 COMMON TO SERVO AND SPINDLE UNITS

3.1.1 STATUS2 Alarm Code - STATUS1 Alarm Code 04 (SP9004)

- (1) Meaning
The input power supply is abnormal (open phase).
- (2) Cause and troubleshooting
 - (a) The input power supply has an open phase.
Check the power supply voltage.
→ If there is no problem with the power supply voltage, check the connections.

3.1.2 STATUS2 Alarm Code - STATUS1 Alarm Code 11 (SP9011)

- (1) Meaning
In the main circuit, the DC voltage at the DC link is abnormally high.
- (2) Cause and troubleshooting
 - (a) Excessive regenerated power
The $\beta iSVSP$ does not have a sufficient capacity.
→ Check the specification of the $\beta iSVSP$.
 - (b) The output impedance of the AC power source is too high.
→ Check the power source output impedance.
(Normal if the voltage variation at maximum output time is within 7%)
 - (c) The main circuit power supply may have been switched off with an emergency stop state released.
→ Check the sequence.
 - (d) The emergency stop line and the MCC line are connected directly.
→ Check the connection of CX3 and CX4.

3.1.3 STATUS2 Alarm Code - STATUS1 Alarm Code 30 (SP9030)

- (1) Meaning
The main circuit power module (IPM) has detected an abnormal condition.
- (2) Cause and troubleshooting
 - (a) Control supply voltage decrease of the power module (IPM)
→ Replace the $\beta iSVSP$.
 - (b) Input supply voltage imbalance
→ Check the input power supply specification.
 - (c) The specification of the AC reactor does not match the $\beta iSVSP$ in use.
→ Check the $\beta iSVSP$ and the specification of the AC reactor.
 - (d) IPM failure
→ Replace the $\beta iSVSP$.

3.1.4 STATUS2 Alarm Code - STATUS1 Alarm Code 33 (SP9033)

- (1) Meaning
The main circuit capacitor was not recharged within the specified time.
- (2) Cause and troubleshooting

- (a) Too many β iSVSP units are connected.
→ Check the specification of the β iSVSP and the β i amplifier for additional axes.
- (b) The DC link is short-circuited.
→ Check the connection.
- (c) The recharge current limiting resistor is defective.
→ Replace the β iSVSP.

3.1.5 STATUS2 Alarm Code - STATUS1 Alarm Code 51 (SP9051)

- (1) Meaning
In the main circuit, the DC voltage (DC link) has dropped.
- (2) Cause and troubleshooting
 - (a) A small power dip has occurred.
→ Check the power supply.
 - (b) Low input power supply voltage
→ Check the power supply specification.
 - (c) The main circuit power supply may have been switched off with an emergency stop state released.
→ Check the sequence.

3.1.6 STATUS2 Alarm Code - STATUS1 Alarm Code 58 (SP9058)

- (1) Meaning
The temperature of the main circuit heat sink has risen abnormally.
- (2) Cause and troubleshooting
 - (a) Cooling fan broken
Check whether the cooling fan rotates normally.
→ Replace the cooling fan.
 - (b) Dust accumulation
→ Clean the cooling system with a vacuum cleaner or the factory air blower.
 - (c) Overload
→ Examine the operating conditions.
 - (d) The control printed-circuit board is not mounted properly.
Be sure to push the β iSVSP control printed-circuit board as far as it will go. If failing to push it properly, pull it out and then push it again.

3.1.7 STATUS2 Alarm Code - STATUS1 Alarm Code 59 (SP9059)

- (1) Meaning
An error was detected in the cooling fan of the control circuit section.
- (2) Cause and troubleshooting
Replace the β iSVSP.
 - (a) The fan for internal cooling is faulty (for the β iSVSP*-18 model only).
→ Replace the fan for internal agitation.
 - (b) The cooling fan for internal cooling is not mounted correctly. (For the β iSVSP*-18 model only)
Be sure to push the internal cooling fan in the upper part as far as it will go.
If failing to push it properly, pull it out and then push it again.
 - (c) The control printed-circuit board is not mounted properly. (For the β iSVSP*-18 model only)
Be sure to push the control printed-circuit board as far as it will go. If failing to push it properly, pull it out and then push it again.
 - (d) The control printed-circuit board or β iSVSP is faulty.
Replace the control printed-circuit board or β iSVSP.

3.1.8 STATUS2 Alarm Code - STATUS1 Alarm Code b1 (SP9111)

- (1) Meaning
The control power supply voltage decrease.
- (2) Cause and troubleshooting
 - (a) Input voltage decrease
→ Check the power supply.
 - (b) The β iSVSP is faulty.
→ If merely turning on the control power supply causes this alarm, replace the β iSVSP.

3.2 SERVO UNIT

The following table lists alarms related to the servo amplifier. See this table while comparing the CNC alarm codes presented in Chapter 2, "Alarm Numbers and Brief Description" with the LED displays of the STATUS 2.

Alarm	STATUS2 display	Major cause	Reference item
Inverter: internal cooling fan stopped	1	(Issued for the β iSVSP*-18 only) <ul style="list-style-type: none"> • The fan is stopped. • The connector/cable of the fan motor is faulty. • Servo amplifier failure 	3.2.1
Inverter: control power supply undervoltage	2	<ul style="list-style-type: none"> • The 24 V control power supply input to the βiSVSP is low. • Connector/cable (CXA2A/C) defective • βiSVSP failure 	3.2.2
Inverter: DC link undervoltage	5	<ul style="list-style-type: none"> • Low input voltage • βiSVSP failure 	3.2.3
Inverter: overheat	6	<ul style="list-style-type: none"> • The motor is being used under a harsh condition. • The ambient temperature is high. • βiSVSP failure 	3.2.4
Inverter: cooling fan stopped of the radiator	F	<ul style="list-style-type: none"> • This alarm is not issued in the βiSVSP. • If this alarm is issued, the βiSVSP may be defective. 	
Communication error between amplifier modules	P	<ul style="list-style-type: none"> • Connector/cable (CXA2A/C) defective • Servo amplifier failure 	3.2.5
Inverter: IPM alarm (L axis)	8.	<ul style="list-style-type: none"> • Short-circuit between power line phases or ground fault in them • Short-circuit between motor winding phases or ground fault in them • βiSVSP failure 	3.2.6
Inverter: IPM alarm (M axis)	9.		
Inverter: IPM alarm (N axis)	A.		
Inverter: IPM alarm (OH) (L axis)	8.	<ul style="list-style-type: none"> • The motor is being used under a harsh condition. • The ambient temperature is high. • βiSVSP failure 	3.2.7
Inverter: IPM alarm (OH) (M axis)	9.		
Inverter: IPM alarm (OH) (N axis)	A.		
Inverter: motor current alarm (L axis)	b	<ul style="list-style-type: none"> • Short-circuit between power line phases or ground fault in them • Short-circuit between motor winding phases or ground fault in them • Incorrect motor ID setting • βiSVSP failure • Motor failure 	3.2.8
Inverter: motor current alarm (M axis)	C		
Inverter: motor current alarm (N axis)	d		

Alarm	STATUS2 display	Major cause	Reference item
Inverter: Control power supply error	- Flashing	<ul style="list-style-type: none"> • Connector/cable (JF*) defective • Motor failure • Servo amplifier failure 	3.2.9
Inverter: FSSB communication error (COP10B)	U	<ul style="list-style-type: none"> • Connector/cable (COP10B) defective • βiSVSP failure • CNC failure 	3.2.10
Inverter: FSSB communication error (COP10A)	L	<ul style="list-style-type: none"> • Connector/cable (COP10A) defective • Servo amplifier failure 	3.2.11

3.2.1 STATUS2 Alarm Code 1 (SV0444)

- (1) Meaning
The internal cooling fan of the inverter is stopped.
- (2) Cause and troubleshooting
 - (a) Check if any foreign matter is caught in the fan.
 - (b) Be sure to push the faceplate (control printed-circuit board) as far as it will go.
 - (c) Check the connection of the fan connector.
 - (d) Replace the fan motor.
 - (e) Replace the servo amplifier.

3.2.2 STATUS2 Alarm Code 2 (SV0434)

- (1) Meaning
The control power supply voltage of the inverter is low.
- (2) Cause and troubleshooting
 - (a) Check the three-phase input voltage of the β iSVSP (the voltage shall not be lower than 85% of the rated input voltage).
 - (b) Check the 24V power supply voltage.
 - (c) Check the connector and cable (CXA2A/C).
 - (d) Replace the β iSVSP.

3.2.3 STATUS2 Alarm Code 5 (SV0435)

- (1) Meaning
The DC link voltage of the inverter is low.
- (2) Cause and troubleshooting
 - (a) The three-phase input voltage level drops.
 - (b) Replace the control printed-circuit board.
 - (c) Replace the β iSVSP.

3.2.4 STATUS2 Alarm Code 6 (SV0602)

- (1) Meaning
The inverter is overheated.
- (2) Cause and troubleshooting
 - (a) Check that the motor is being used at or below its continuous rating.
 - (b) Check that the cooling capacity of the cabinet is sufficient (inspect the fans and filters).
 - (c) Check that the ambient temperature is not too high.
 - (d) Be sure to push the faceplate (control printed-circuit board) as far as it will go.
 - (e) Replace the β iSVSP.

3.2.5 STATUS2 Alarm Code P (SV0604)

- (1) Meaning
There is an error in communication between amplifiers.
- (2) Cause and troubleshooting
 - (a) Check the connector and cable (CXA2A/C).
 - (b) Replace the control printed-circuit board.
 - (c) Replace the β iSVSP.

3.2.6 STATUS2 Alarm Code 8. , 9. , A. (SV0449)

- (1) Meaning
An alarm is output from the IPM of the inverter.
- (2) Cause and troubleshooting
 - (a) Be sure to push the control printed-circuit board as far as it will go.
 - (b) Disconnect the motor power lines from the β iSVSP, and release the β iSVSP from an emergency stop condition.
 - <1> If no IPM alarm condition has occurred
→ Go to (c).
 - <2> If an IPM alarm condition has occurred
→ Replace the β iSVSP.
 - (c) Disconnect the motor power lines from the β iSVSP, and check the insulation between PE and the motor power line U, V, or W.
 - <1> If the insulation is deteriorated
→ Go to (d).
 - <2> If the insulation is normal
→ Replace the β iSVSP.
 - (d) Disconnect the motor from its power lines, and check whether the insulation of the motor or power lines is deteriorated.
 - <1> If the insulation of the motor is deteriorated
→ Replace the motor.
 - <2> If the insulation of any power line is deteriorated
→ Replace the power line.

3.2.7 STATUS2 Alarm Code 8. , 9. , A. (SV0603)

- (1) Meaning
An overheat alarm is output from the IPM of the inverter.
- (2) Cause and troubleshooting
 - (a) Be sure to push the control printed-circuit board as far as it will go.
 - (b) Check that the heat sink cooling fan is running.
 - (c) Check that the motor is being used at or below its continuous rating.
 - (d) Check that the cooling capacity of the cabinet is sufficient (inspect the fans and filters).
 - (e) Check that the ambient temperature is not too high.
 - (f) Replace the β iSVSP.

3.2.8 STATUS2 Alarm Code b , c , d (SV0438)

- (1) Meaning
A motor current error was detected.
- (2) Cause and troubleshooting
 - (a) Checking the servo parameters

Referring to "FANUC AC SERVO MOTOR α i series/FANUC AC SERVO MOTOR β i series/FANUC LINEAR MOTOR LiS series/FANUC SYNCHRONOUS BUILT-IN SERVO MOTOR DiS series Parameter Manual (B-65270EN)," check whether the following parameters have default values.

Series 15i	No.1809	No.1852	No.1853
Series 16i, 18i, 20i, 21i, 0i Power Mate i	No.2004	No.2040	No.2041

Alternatively, if an abnormal motor current alarm condition occurs only on rapid acceleration/deceleration, it is probable that the motor is being used under too harsh a condition. Increase the acceleration/deceleration time constant, and see what will occur.

- (b) Be sure to push the control printed-circuit board as far as it will go.
- (c) Disconnect the motor power lines from the β iSVSP, and release the β iSVSP from an emergency stop condition.
 - <1> If no abnormal motor current occurs
 - Go to (d).
 - <2> If an abnormal motor current occurs
 - Replace the β iSVSP.
- (d) Disconnect the motor power lines from the β iSVSP, and check the insulation between PE and the motor power line U, V, or W.
 - <1> If the insulation is deteriorated
 - Go to (e).
 - <2> If the insulation is normal
 - Replace the β iSVSP.
- (e) Disconnect the motor from its power lines, and check whether the insulation of the motor or power lines is deteriorated.
 - <1> If the insulation of the motor is deteriorated
 - Replace the motor.
 - <2> If the insulation of any power line is deteriorated
 - Replace the power line.

3.2.9 Alarm Code "-" Flashing

- (1) Meaning
There is an error in the control power supply of the inverter.
- (2) Cause and troubleshooting
 - (a) Disconnect the feedback cable (JF*) from the β iSVSP, and turn on the power.
 - <1> If the flashing does not stop
 - Replace the β iSVSP.
 - <2> If the flashing stops
 - Go to (b).
 - (b) Disconnect the feedback cable (JF*) from the pulse coder, and turn on the power. (Keep it connected to the β iSVSP side.)
 - <1> If the flashing does not stop
 - Replace the cable.
 - <2> If the flashing stops
 - Replace the motor.

3.2.10 STATUS2 Alarm Code U

- (1) Meaning
Inverter: FSSB communication error (COP10B) ^(NOTE)
- (2) Cause and troubleshooting
 - (a) Replace the optical cable (COP10B) of the servo amplifier that is nearest the CNC on which "U" is displayed. (In Fig. 3.2.10, the cable between UNIT2 and UNIT3)
 - (b) Replace the servo amplifier that is nearest the CNC on which "U" is displayed. (In Fig. 3.2.10, UNIT3)
 - (c) Replace the COP10B-side servo amplifier of the servo amplifier that is nearest the CNC on which "U" is displayed. (In Fig. 3.2.10, UNIT2)
 - (d) Replace the servo card in the CNC.

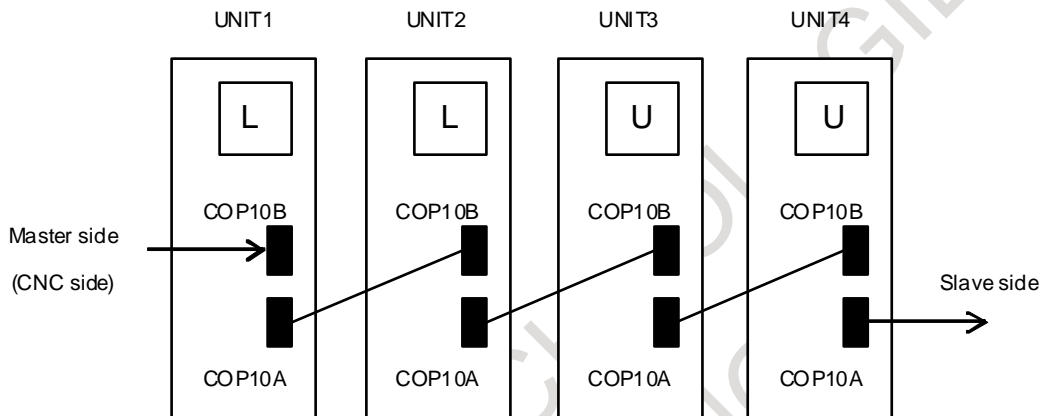

Fig. 3.2.10

NOTE

When the CNC power is turned on, "U" blinks momentarily, and then "-" steadily lights. This is not a failure, though.

3.2.11 Alarm Code L

- (1) Meaning
Inverter: FSSB communication error (COP10A)
- (2) Cause and troubleshooting
 - (a) Replace the optical cable (COP10A) of the servo amplifier that is farthest the CNC on which "L" is displayed. (In Fig. 3.2. 11, the cable between UNIT2 and UNIT3)
 - (b) Replace the servo amplifier that is farthest the CNC on which "L" is displayed. (In Fig. 3.2. 11, UNIT2)
 - (c) Replace the COP10A-side servo amplifier of the servo amplifier that is farthest the CNC on which "L" is displayed. (In Fig. 3.2. 11, UNIT3)

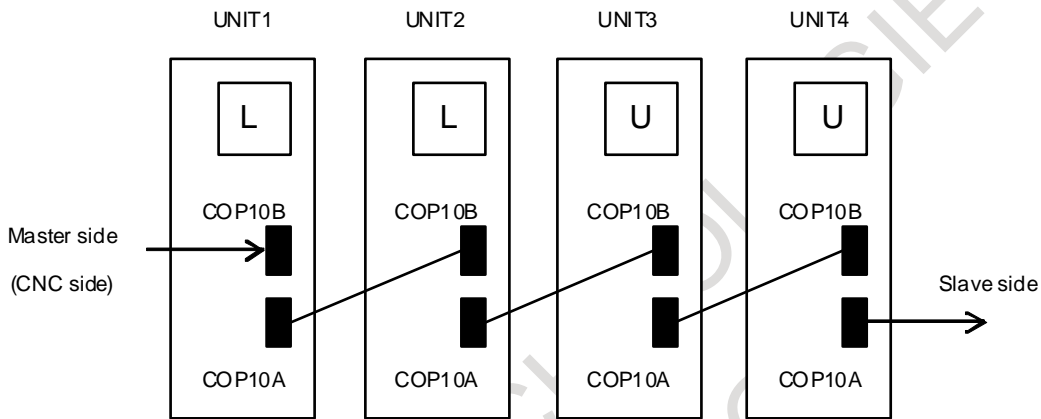

Fig. 3.2.11

3.3 SERVO SOFTWARE

If a servo alarm is issued, an alarm message is output, and details of the alarm are also displayed on the servo adjustment screen or the diagnosis screen. Using the alarm identification table given in this section, determine the alarm, and take a proper action.

3.3.1 Servo Tuning Screen

The following procedure can be used to display the servo tuning screen.

- **Series 0i**

SYSTEM → [SYSTEM] → [▷] → [SV-PRM] → [SV-TUN]

If the servo setting screen does not appear, specify the following parameter, then switch the CNC off and on again.

	#7	#6	#5	#4	#3	#2	#1	#0
3111								SVS

SVS(#0) 1: Displays the servo setting screen.

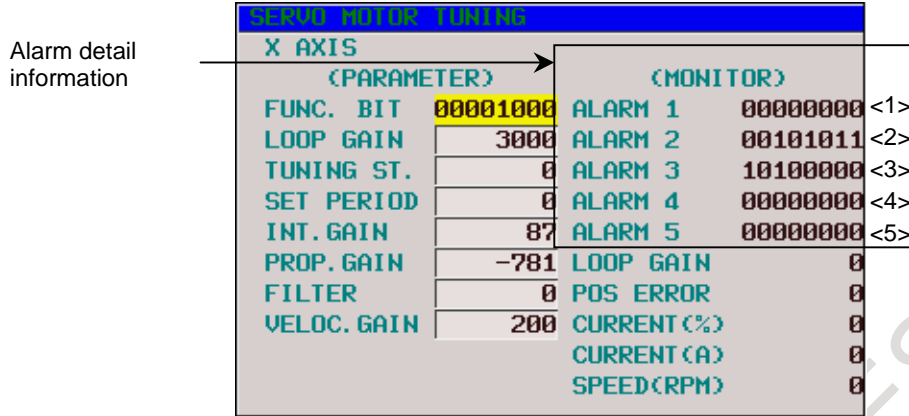

Fig. 3.3.1 (a) Servo adjustment screen

3.3.2 Diagnosis Screen

The alarm items of the servo tuning screen correspond to the diagnosis screen numbers indicated in the table below.

Table 3.3.2 (a) Correspondence between the servo tuning screen and diagnosis screen

Alarm No.	Series 15i	Series 16i, 18i, 21i, 0i
<1> Alarm 1	No 3014 + 20(X-1)	No 200
<2> Alarm 2	3015 + 20(X-1)	201
<3> Alarm 3	3016 + 20(X-1)	202
<4> Alarm 4	3017 + 20(X-1)	203
<5> Alarm 5	_____	204
<6> Alarm 6	_____	_____
<7> Alarm 7	_____	205
<8> Alarm 8	_____	206
<9> Alarm 9	_____	_____

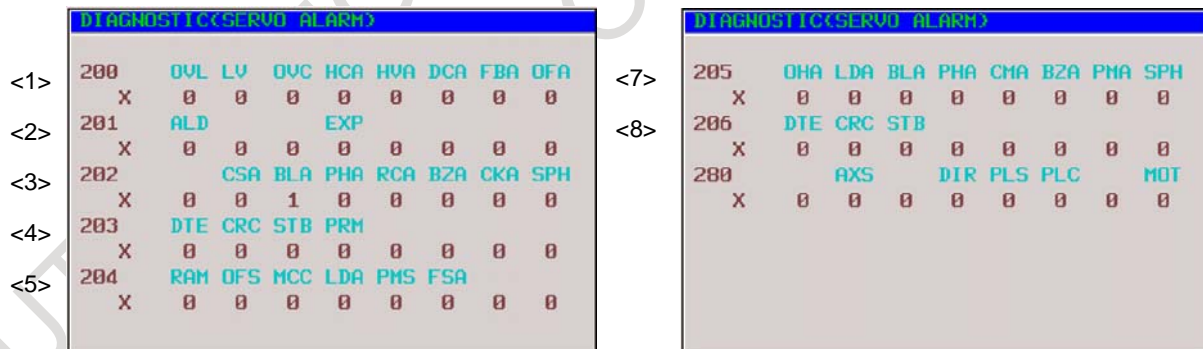

Fig. 3.3.2 Diagnosis screen

The table below indicates the names of the alarm bits.

Table 3.3.2 (b) List of alarm bit names

	#7	#6	#5	#4	#3	#2	#1	#0
<1> Alarm 1	OVL	LVA	OVC	HCA	HVA	DCA	FBA	OFA
<2> Alarm 2	ALD			EXP				
<3> Alarm 3		CSA	BLA	PHA	RCA	BZA	CKA	SPH
<4> Alarm 4	DTE	CRC	STB	PRM				
<5> Alarm 5		OFS	MCC	LDM	PMS	FAN	DAL	ABF
<6> Alarm 6					SFA			
<7> Alarm 7	OHA	LDA	BLA	PHA	CMA	BZA	PMA	SPH
<8> Alarm 8	DTE	CRC	STB	SPD				
<9> Alarm 9		FSD			SVE	IDW	NCE	IFE

NOTE

The empty fields do not represent alarm codes.

3.3.3 Overload Alarm (Soft Thermal, OVC)

(Alarm identification method)

	#7	#6	#5	#4	#3	#2	#1	#0
<1> Alarm 1	OVL	LVA	OVC	HCA	HVA	DCA	FBA	OFA

(Action)

- (1) Make sure that the motor is not vibrating.
 - ⇒ If a motor vibrates, the current flowing in it becomes more than necessary, resulting in an alarm.
- (2) Make sure that the power lead to the motor is connected correctly.
 - ⇒ If the connection is incorrect, an abnormal current flows in the motor, resulting in an alarm.
- (3) Make sure that the following parameters are set correctly.
 - ⇒ An overload alarm is issued based on the result of calculation of these parameters. Be sure to set them to the standard values. For details of the standard values, refer to the FANUC AC SERVO MOTOR α i series/FANUC AC SERVO MOTOR β i series/FANUC LINEAR MOTOR LiS series/FANUC SYNCHRONOUS BUILT-IN SERVO MOTOR DiS series Parameter Manual (B-65270EN).
- (4) Check the operation conditions. The machine load may be too heavy for the motor specification.

No. 2062 (FS0 _i)	Overload protection coefficient (OVC1)
No. 2063 (FS0 _i)	Overload protection coefficient (OVC2)
No. 2065 (FS0 _i)	Overload protection coefficient (OVCLMT)
No. 2162 (FS0 _i)	Overload protection coefficient (OVC21)
No. 2163 (FS0 _i)	Overload protection coefficient (OVC22)
No. 2164 (FS0 _i)	Overload protection coefficient (OVCLMT2)

3.3.4 Feedback Disconnected Alarm

(Alarm identification method)

	#7	#6	#5	#4	#3	#2	#1	#0
<1> Alarm 1	OVL	LVA	OVC	HCA	HVA	DCA	FBA	OFA
<2> Alarm 2	ALD			EXP				
<6> Alarm 6					SFA			

FBA	ALD	EXP	SFA	Alarm description	Action
1	1	1	0	Hard disconnection (separate phase A/B)	1
1	0	0	0	Soft disconnection (closed loop)	2
1	0	0	1	Soft disconnection (<i>αi</i> Pulsecoder)	3

(Action)

Action 1:

This alarm is issued when a separate phase A/B scale is used. Check if the phase A/B detector is connected correctly.

Action 2:

This alarm is issued when the position feedback pulse variation is small relative to the velocity feedback pulse variation. This means that this alarm is not issued when a semi-full is used. Check if the separate detector outputs position feedback pulses correctly. If position feedback pulses are output correctly, it is considered that the motor alone is rotating in the reverse direction at the start of machine operation because of a large backlash between the motor position and scale position.

	#7	#6	#5	#4	#3	#2	#1	#0
No. 2003 (FS0 _i)							TGAL	

TGAL(#1) 1: Uses the parameter for the soft disconnection alarm detection level.

No. 2064 (FS0 _i)	Soft disconnection alarm level							
------------------------------	--------------------------------	--	--	--	--	--	--	--

Standard setting 4: Alarm issued for a 1/8 rotation of the motor.
Increase this value.

Action 3:

This alarm is issued when synchronization between the absolute position data sent from the built-in Pulsecoder and phase data is lost. Turn off the power to the CNC, then detach the Pulsecoder cable then attach it again. If this alarm is still issued, replace the Pulsecoder.

3.3.5 Overheat Alarm

(Alarm identification method)

	#7	#6	#5	#4	#3	#2	#1	#0
<1> Alarm 1	OVL	LVA	OVC	HCA	HVA	DCA	FBA	OFA
<2> Alarm 2	ALD			EXP				

OVL	ALD	EXP	Alarm description	Action
1	1	0	Motor overheat	1
1	0	0	Amplifier overheat	1

(Action)

Action 1:

If this alarm is issued after a long-time of continuous operation, it is considered that the motor and amplifier are overheated. Stop operation for a while, then make a check. If this alarm is still issued after the power is off for about 10 minutes then is turned on again, the thermostat is considered to be faulty. If this alarm is issued intermittently, increase the time constant or increase stop time in the program to suppress the rise in temperature.

3.3.6 Invalid Servo Parameter Setting Alarm

The invalid servo parameter setting alarm is issued when a setting out of the specifiable range is specified, or an overflow has occurred in an internal calculation. When an invalid parameter is detected on the servo side, alarm 4 #4 (PRM) = 1 results.

(Alarm identification method)

	#7	#6	#5	#4	#3	#2	#1	#0
<4> Alarm 4	DTE	CRC	STB	PRM				

For details and action required when the invalid servo parameter setting alarm is issued on the servo side, refer to the FANUC AC SERVO MOTOR αi series/FANUC AC SERVO MOTOR βi series/FANUC LINEAR MOTOR LiS series/FANUC SYNCHRONOUS BUILT-IN SERVO MOTOR DiS series Parameter Manual (B-65270EN).

(Reference information)

Method of checking details of an invalid parameter detected on the servo side

(For Series 0i)

A number is indicated in No. 352 of the diagnosis screen.

3.3.7 Alarms Related to Pulsecoder and Separate Serial Detector

(Bits for alarm identification)

	#7	#6	#5	#4	#3	#2	#1	#0
<1> Alarm 1	OVL	LVA	OVC	HCA	HVA	DCA	FBA	OFA
<2> Alarm 2	ALD			EXP				
<3> Alarm 3		CSA	BLA	PHA	RCA	BZA	CKA	SPH
<4> Alarm 4	DTE	CRC	STB	PRM				
<5> Alarm 5		OFS	MCC	LDM	PMS	FAN	DAL	ABF
<6> Alarm 6					SFA			
<7> Alarm 7	OHA	LDA	BLA	PHA	CMA	BZA	PMA	SPH
<8> Alarm 8	DTE	CRC	STB	SPD				
<9> Alarm 9		FSD			SVE	IDW	NCE	IFE

(1) For a built-in Pulsecoder

An alarm is determined from the bits of alarms 1, 2, 3, and 5. The table below indicates the meaning of each bit.

Alarm 3							Alarm 5		1	Alarm 2		Alarm description	Action
CSA	BLA	PHA	RCA	BZA	CKA	SPH	LDM	PMA	FBA	ALD	EXP		
						1						Soft phase alarm	2
				1								Zero battery voltage	1
			1						1	1	0	Count error alarm	2
		1										Phase alarm	2
	1											Battery voltage decrease ^(Caution)	1
								1				Pulse error alarm	
							1					LED error alarm	

⚠ CAUTION

An alarm for which no action number is given is considered to be caused by a Pulsecoder failure. Replace the Pulsecoder.

3. TROUBLESHOOTING AND ACTION

(2) For a separate serial detector

An alarm is determined from the bits of alarm 7. The table below indicates the meaning of each bit.

Alarm 7								Alarm description	Action
OHA	LDA	BLA	PHA	CMA	BZA	PMA	SPH		
							1	Soft phase alarm	2
						1		Pulse error alarm	
					1			Zero battery voltage	1
				1				Count error alarm	2
			1					Phase alarm	2
		1						Battery voltage decrease (Caution)	1
	1							LED error alarm	
1								Separate detector alarm	3

NOTE

An alarm for which no action number is given is considered to be caused by a detector failure. Replace the detector.

(Action)

Action 1: Battery-related alarms

Check if a battery is connected. When the power is turned on for the first time after a battery is connected, the zero battery voltage alarm is issued. In such a case, turn off the power, then turn on the power again. If the alarm is still issued, check the battery voltage. If the battery voltage decrease alarm is issued, check the voltage, and replace the battery as required.

Action 2: Alarms that may be issued for noise

If an alarm is issued intermittently or after emergency stop cancellation, noise is probably the cause. So, provide noise protection. If the same alarm is still issued after noise protection is provided, replace the detector.

Action 3: Alarm condition detected by the separate detector

If the separate detector detects an alarm condition, contact the manufacturer of the detector for information on troubleshooting.

(3) Alarms related to serial communication

An alarm is determined from the bits of alarms 4 and 8.

Alarm 4			Alarm 8			Alarm description
DTE	CRC	STB	DTE	CRC	STB	
1						Serial Pulsecoder communication alarm
	1					
		1				Separate serial Pulsecoder communication alarm
			1			
				1		
					1	

Action:

Serial communication is not performed correctly. Check if the cable is connected correctly and is not broken. If CRC or STB is issued, noise may be the cause. So, provide noise protection. If CRC or STB is always issued after the power is turned on, the Pulsecoder or amplifier control board or the pulse module may be faulty.

3.3.8 Other Alarms

(Alarm identification method)

<5> Alarm 5	#7	#6	#5	#4	#3	#2	#1	#0
		OFS	MCC	LDM	PMS	FAN	DAL	ABF

OFS	DAL	ABF	Alarm description	Action
		1	Feedback mismatch alarm	1
	1		Excessive semi-full error alarm	2
1			Current offset error alarm	3

(Action)

Action 1:

This alarm is issued when the move direction of the position detector is opposite to the move direction of the speed detector. Check the rotation direction of the separate detector. If the rotation direction of the separate detector is opposite to the rotation direction of the motor, take the following action:

For a phase A/B detector:

Reverse the connections of A and \bar{A} .

For a serial detector:

Reverse the setting of the signal direction of the separate detector.

In the Series 90B0/G(07) and subsequent editions, the following settings enable signal directions in the A/B phase detector to be inverted.

	#7	#6	#5	#4	#3	#2	#1	#0
No. 1960 (FS15i)								RVRSE
No. 2018 (FS16i)								

RVRSE(#0) Reverses the signal direction of the separate detector.

0: Does not reverse the signal direction of the separate detector.

1: Reverses the signal direction of the separate detector.

If a large distortion exists between the motor and separate detector, this alarm may be issued in the case of abrupt acceleration/deceleration. In such a case, modify the detection level.

	#7	#6	#5	#4	#3	#2	#1	#0
No. 1741 (FS15i)							RNLV	
No. 2201 (FS16i)								

RNLV(#1) Modifies the feedback mismatch alarm detection level.

1: Detected with 1000 min⁻¹ or more

0: Detected with 600 min⁻¹ or more

Action 2:

This alarm is issued when the difference between the motor position and separate detector position exceeds the excessive semi-full error level. Check if the conversion efficient for dual position feedback is set correctly. If the conversion efficient is set correctly, increase the alarm level. If this alarm is still issued after the level is modified, check the connection direction of the scale.

No. 2078 (FS0i)	Dual position feedback conversion coefficient (numerator)
-----------------	---

No. 2079 (FS0i)	Dual position feedback conversion coefficient (denominator)
-----------------	---

$$\text{Conversion coefficient} = \frac{\left(\frac{\text{Number of feedback pulses per motor revolution (detection unit)}}{1,000,000} \right)}{1,000,000}$$

No. 2118 (FS0i)

Dual position feedback semi-full error level

[Setting] Detection unit. When 0 is set, no detection is made.

Action 3:

The current offset value of the current detector (equivalent to the current value in the emergency stop state) is abnormally high. If this alarm is still issued after the power is turned off then back on, the current detector is faulty. Replace the β iSVSP.

3.4 SPINDLE UNIT

When an alarm is issued, the alarm number (SPxxxx) is displayed on the CNC screen, and at the same time, the alarm LED (red) on the STATUS1 display of the spindle section turns on, and the alarm code is displayed on the 2-digit 7-segment LEDs. The following is a description of each alarm and the action to take for recovery. In some cases, there may arise a need to replace the control printed-circuit board and other devices. Before replacement work, be sure to turn off the power to the entire machine and check for safety. After replacement work, check that the wiring is correct and check the surroundings before turning on the power to the machine again.

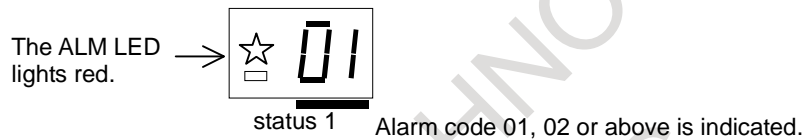

3.4.1 Alarm Code 01 (SP9001)

The inside temperature of the motor is higher than the specified temperature.

- (1) If this alarm is issued during cutting (the motor temperature is high)
 - (a) Check the cooling state of the motor.
 - <1> If the cooling fan of the spindle motor is stopped, check the power supply of the cooling fan. If the cooling fan is still inoperative, replace it with a new one.
 - <2> When a liquid-cooled motor is used, check the cooling system.
 - <3> When the ambient temperature of the spindle motor is higher than the specified temperature, lower the ambient temperature to satisfy the specification.
 - (b) Recheck the cutting conditions.
- (2) If this alarm is issued under a light load (the motor temperature is high)
 - (a) When the frequency of acceleration/deceleration is too high
Set such a use condition that the average including output at acceleration/deceleration does not exceed the continuous rating.
 - (b) The parameters specific to the motor are not correctly.
Referring to "FANUC AC SPINDLE MOTOR α i series / FANUC AC SPINDLE MOTOR β i series / FANUC BUILT-IN SPINDLE MOTOR Bi series Parameter Manual (B-65280EN)," check the motor-specific parameters.
- (3) If this alarm is issued when the motor temperature is low
 - (a) The spindle motor feedback cable is faulty.
Replace the cable.
 - (b) The parameters specific to the motor are not set correctly.
Referring to " FANUC AC SPINDLE MOTOR α i series / FANUC AC SPINDLE MOTOR β i series / FANUC BUILT-IN SPINDLE MOTOR Bi series Parameter Manual (B-65280EN)," check the motor-specific parameters.

FS0i	For β i series motor
4134	Motor-specific parameter

- (c) The control printed-circuit board is faulty.
Replace the control printed-circuit board or β iSVSP.
- (d) The spindle motor (internal thermostat) is faulty.
Replace the spindle motor.
- (e) The cable of the temperature sensor is connected incorrectly.

3.4.2 Alarm Code 02 (SP9002)

The actual motor speed is largely deviated from the commanded speed.

- (1) If this alarm is issued during motor acceleration
 - (a) The parameter setting of acceleration/deceleration time is incorrect.
Set the following parameter with the actual acceleration/deceleration time for your machine plus some margin.

FS0i	Description
4082	Setting of acceleration/deceleration time

- (b) The parameter for the speed detector is not set correctly.
Referring to "FANUC AC SPINDLE MOTOR α i series / FANUC AC SPINDLE MOTOR β i series / FANUC BUILT-IN SPINDLE MOTOR Bi series Parameter Manual (B-65280EN)," set a correct value.
- (2) If this alarm is issued at a heavy cutting load
 - (a) The cutting load has exceeded the motor output power.
Check the load meter indication, and review the use condition.
 - (b) The parameters for output restriction are not set correctly.
Check that the settings of the following parameters satisfy the machine and motor specifications:

FS0i	Description
4028	Output restriction pattern setting
4029	Output restriction value

- (c) The parameters specific to the motor are not correctly.
Referring to "FANUC AC SPINDLE MOTOR α i series / FANUC AC SPINDLE MOTOR β i series / FANUC BUILT-IN SPINDLE MOTOR Bi series Parameter Manual (B-65280EN)," check the motor-specific parameters.
- (3) If this alarm is issued even during rotation with no load
 - (a) β iSVSP is faulty.
Replace the control printed-circuit board or β iSVSP.
 - (b) The motor windings are disconnected.
Perform a continuity check on the motor windings.
 - (c) The power line is disconnected.
Perform a continuity check on the power line.

3.4.3 Alarm Code 03 (SP9003)

The fuse of the DC link melted. (The voltage of the DC link is insufficient.) This alarm is checked when an emergency stop is released.

- (1) If the alarm is issued during spindle operation (rotation)
Probable causes of this alarm are:
 - <1> The power line is grounded.
 - <2> The motor windings are grounded.
 - <3> The IGBT and IPM modules are faulty.
- (2) If, when an emergency stop is released or when the CNC starts up, the MCC of the common power input turns on, and is turned off due to this alarm

- (a) The βi SVSP control board is not mounted correctly.
Be sure to push the faceplate of the βi SVSP as far as it will go. (This alarm may be displayed due to the poor contact of the connector connecting the control board to the power board.)
- (b) βi SVSP is faulty.
Replace the control printed-circuit board or βi SVSP.

3.4.4 Alarm Code 06 (SP9006)

An error was detected in the temperature sensor inside the spindle motor, or the disconnection of the temperature sensor cable was detected.

- (1) The motor-specific parameters are incorrect.
Referring to "FANUC AC SPINDLE MOTOR αi series / FANUC AC SPINDLE MOTOR βi series / FANUC BUILT-IN SPINDLE MOTOR $B i$ series Parameter Manual (B-65280EN)," check the motor-specific parameters.
- (2) Feedback cable is faulty.
Replace the feedback cable.
- (3) The control printed-circuit board is faulty.
Replace the control printed-circuit board or βi SVSP.
- (4) The temperature sensor inside the spindle motor is abnormal.
Replace the internal temperature sensor or the spindle motor.
- (5) The ambient temperature of the spindle motor is outside the range of the specification (low).
The ambient temperature of the spindle motor must be in the range of the specification.
- (6) The temperature sensor inside the spindle motor and the windings are short-circuited.
Coolant and so on may enter the inside of the spindle motor, so that the internal temperature sensor and the windings may be short-circuited. Check if coolant and so on enter the inside of the spindle motor.

3.4.5 Alarm Code 07 (SP9007)

It was detected that the rotation of the spindle motor exceeded the maximum rotation speed of 115% (standard parameter setting).

- (1) If this alarm is issued during spindle synchronization
If one of the motors operating in spindle synchronization is deactivated (SFR or SRV) and activated again, the spindle motor may accelerate to its maximum rotation speed in order to eliminate the position error accumulated while the motor is off, resulting in this alarm being issued.
Modify the ladder in such a way that this sequence will not be used.
- (2) βi SVSP is faulty.
Replace the control printed-circuit board or βi SVSP.
- (3) The sensor is faulty.
Replace the sensor.

3.4.6 Alarm Code 09 (SP9009)

It was detected that the temperature of the radiator of the βi SVSP was abnormally high.

- (1) If this alarm is issued during cutting (the radiator temperature is high)
 - (a) If this alarm is issued when the load meter reads a value below the continuous rating of the βi SVSP, check the cooling state of the radiator.
 - <1> The radiator is not cooled sufficiently if the filter of the air inlet port of the control panel is soiled or if there are any objects that block the flow of air to the radiator. Make the necessary improvement to ensure a sufficient flow of air to the radiator.

- <2> If the ambient temperature of the β iSVSP is outside the specification range (high), make the necessary improvement so that it falls within the specification range.
- (b) If this alarm is issued with the load meter being equal to or greater than the continuous rating of the β iSVSP, review the cutting conditions.
 - (c) If the radiator of the β iSVSP is soiled remarkably, clean it with air and so on. Also, consider such a control panel structure in which the radiator is not splashed directly with coolant and so on.
- (2) If this alarm is issued under a light load (the radiator temperature is high)
- (a) When the frequency of acceleration/deceleration is too high
Make the necessary modifications so that the average output of the spindle motor including the output during acceleration/deceleration does not exceed the continuous rated output.
 - (b) The motor-specific parameters are incorrect.
Referring to "FANUC AC SPINDLE MOTOR α i series / FANUC AC SPINDLE MOTOR β i series / FANUC BUILT-IN SPINDLE MOTOR Bi series Parameter Manual (B-65280EN)," check the motor-specific parameters.
- (3) If this alarm is displayed immediately after the power is turned on
- (a) The control printed-circuit board is not mounted properly.
Be sure to push the β iSVSP control printed-circuit board as far as it will go. If failing to push it properly, pull it out and then push it again. (This alarm may be displayed due to the poor contact of the connector connecting the control printed-circuit board and the power printed-circuit board.)
 - (b) β iSVSP is faulty.
Replace the control printed-circuit board or β iSVSP.

3.4.7 Alarm Code 10 (SP9010)

It was detected that the voltage of the control power supply (24 VDC) was low.

The control power supply (24 VDC), power cable, or β iSVSP is faulty.

Replace the control power supply (24 VDC), power cable, or β iSVSP.

3.4.8 Alarm Code 12 (SP9012)

An excessively large current flowed into the main circuit.

This alarm indicates that the power module (IPM) of the main circuit detected an error such as an excessive load, overcurrent.

- (1) Perform a check, referring to the description of alarm code 09.
- (2) The β iSVSP control board is not mounted correctly.
Be sure to push the faceplate as far as it will go. (This alarm may be displayed due to the poor contact of the connector connecting the control board to the power board.)
- (3) If this alarm is issued immediately after a spindle rotation command is specified
 - (a) The motor power line is faulty.
Check for a short circuit between motor power lines and short-circuit to ground, and replace the power line as required.
 - (b) The motor winding has an insulation failure.
If the motor is short-circuited to ground, replace the motor.
 - (c) The parameters specific to the motor are not correctly.
Referring to "FANUC AC SPINDLE MOTOR α i series / FANUC AC SPINDLE MOTOR β i series / FANUC BUILT-IN SPINDLE MOTOR Bi series Parameter Manual (B-65280EN)," check the motor-specific parameters.
 - (d) β iSVSP is faulty.
A power element (IPM) may be destroyed. Replace the β iSVSP.
- (4) If this alarm is issued during spindle rotation

- (a) A power element is destroyed.
A power element (IPM) may be destroyed. Replace the β iSVSP.
If the β iSVSP setting condition is not satisfied, or cooling is insufficient because the heat sink is dirty, the power elements may be destroyed.
When the heat sink on the back of the β iSVSP is too dirty, clean the heat sink, for example, by blowing air.
- (b) The parameters specific to the motor are not correctly.
Referring to "FANUC AC SPINDLE MOTOR α i series / FANUC AC SPINDLE MOTOR β i series / FANUC BUILT-IN SPINDLE MOTOR Bi series Parameter Manual (B-65280EN)," check the motor-specific parameters.
- (c) The power line or the motor windings are disconnected.
The power line or the motor windings may be disconnected. Perform a continuity check on them.
- (d) The belt slips.
The belt between the spindle and motor may slip. (For the spindle motor β iC series only, this may cause this alarm to be issued.) Clean the pulley, and tighten the belt again.

3.4.9 Alarm Code 13 (SP9013)

An error was detected in the internal RAM of the CPU.

β iSVSP is faulty. Replace the control printed-circuit board or β iSVSP.

3.4.10 Alarm Code 14 (SP9014)

It was detected that the amplifier ID data did not match the software series combination.

β iSVSP is faulty. Replace the control printed-circuit board or β iSVSP.

3.4.11 Alarm Code 15 (SP9015)

In speed range switching control, the switching operation sequence was not executed correctly. This alarm is issued if one second or more elapses from the transition of a switch request signal (RSL) until a power lead state check signal (RCH or RCHHG) makes a transition.

Troubleshooting when this alarm is issued

- (a) The magnetic contactor (switch unit) for power lead switching is faulty.
If the contact is inoperative, check the power supply of the magnetic contactor.
If the magnetic contactor is still inoperative, replace the magnetic contactor.
- (b) The I/O unit or wiring for checking the contact of the magnetic contactor is faulty.
If a defect is found in the I/O unit or wiring, replace the I/O unit or wiring.
- (c) The sequence (ladder) is incorrect.
Modify the sequence so that switching is completed within 1 second.

3.4.12 Alarm Code 16 (SP9016)

In the dual check safety function, an error was found in the test on the internal RAM of the CPU. This alarm is checked only when the dual check safety function is used.

β iSVSP is faulty. Replace the control printed-circuit board or β iSVSP.

3.4.13 Alarm Code 17 (SP9017)

An error was detected in amplifier ID data.

The β iSVSP control printed-circuit board has poor contact, or the β iSVSP is abnormal. Check if the β iSVSP control printed-circuit board is mounted properly. If it is mounted properly, replace the β iSVSP.

3.4.14 Alarm Code 18 (SP9018)

In communication between CPU and ROM inside the β iSVSP, a sum check error was detected. β iSVSP is faulty. Replace the control printed-circuit board or β iSVSP.

3.4.15 Alarm Codes 19 and 20 (SP9019, SP9020)

The offset voltage of the phase U (alarm code 19) or phase V (alarm code 20) current detection circuit is excessively high. A check is made when the power is turned on.

Check if the β iSVSP control printed-circuit board is mounted properly. If it is mounted properly, replace the β iSVSP.

3.4.16 Alarm Code 21 (SP9021)

It was detected that the polarity (rotating direction) of the position sensor was not set correctly.

- (a) Check the position sensor polarity parameter (bit 4 of parameter No. 4001). Refer to FANUC AC SPINDLE MOTOR α i series / FANUC AC SPINDLE MOTOR β i series / FANUC BUILT-IN SPINDLE MOTOR Bi series Parameter Manual (B-65280EN).
- (b) Check the feedback cable of the position sensor. If the A/B phase signals are connected in the wrong way, correct the cable.
- (c) If the spindle is connected with a V belt, check if the belt slips.
- (d) Check if the signals of the position sensor are normal.
- (e) If none of the above errors is found, the β iSVSP may be faulty. Replace the β iSVSP.

3.4.17 Alarm Code 22 (SP9022)

A current that exceeded the rating flowed continuously for a short time. Probable causes are the high frequency of acceleration/deceleration and high cutting load.

- (1) The operating conditions for the spindle are severe.
Probable causes include the high acceleration/deceleration frequency of the spindle and high cutting load. Review the operating conditions for the spindle.
- (2) The motor-specific parameters are incorrect.
Referring to "FANUC AC SPINDLE MOTOR α i series / FANUC AC SPINDLE MOTOR β i series / FANUC BUILT-IN SPINDLE MOTOR Bi series Parameter Manual (B-65280EN)," check the motor-specific parameters.

3.4.18 Alarm Code 24 (SP9024)

Serial communication data transferred between the CNC and β iSVSP contains an error. ^(Note)

- (1) Serial communication data between CNC and β iSVSP (connected with an electric cable) is abnormal due to noise.

- (a) The cable wiring length exceeds the specification range.
Correct it so that the cable length is appropriate. For details, refer to the FANUC SERVO AMPLIFIER βi series DESCRIPTIONS (B-65322EN).
- (b) The feedback cable and the power line of the motor are bundled together.
If the feedback cable and the power line of the motor are bundled together, check the FANUC SERVO AMPLIFIER βi series DESCRIPTIONS (B-65322EN), and bundle them separately.
- (2) The motor-specific parameters are incorrect.
 - (a) Referring to "FANUC AC SPINDLE MOTOR αi series / FANUC AC SPINDLE MOTOR βi series / FANUC BUILT-IN SPINDLE MOTOR $B i$ series Parameter Manual (B-65280EN)," check the motor-specific parameters.
- (3) The communication cable between CNC and βi SVSP is faulty.
 - (a) Replace the communication cable.
If an optical I/O link adapter is used, the optical I/O link adapter or the optical cable may be faulty.
 - (b) βi SVSP is faulty.
Replace the control printed-circuit board or βi SVSP.
 - (c) CNC is faulty.
Replace the board or module related to the serial spindle.

NOTE

This alarm is issued also if the CNC power is off. This is not a failure, though.

3.4.19 Alarm Code 27 (SP9027)

An error was detected in communication between αi position coder and βi SVSP.

- (1) If this alarm is issued when the motor is deactivated
 - (a) The setting of a parameter is incorrect.
Referring to "FANUC AC SPINDLE MOTOR αi series / FANUC AC SPINDLE MOTOR βi series / FANUC BUILT-IN SPINDLE MOTOR $B i$ series Parameter Manual (B-65280EN)," check the parameter for sensor setting.
 - (b) The βi SVSP side of the feedback cable of the αi position coder is connected incorrectly.
Referring to the FANUC SERVO AMPLIFIER βi series DESCRIPTIONS (B-65322EN), check the connection.
 - (c) The feedback cable of the αi position coder is broken.
Replace the feedback cable.
 - (d) βi SVSP is faulty.
Replace the control printed-circuit board or βi SVSP.
- (2) If the alarm is issued when the feedback cable is moved (as in the case where the spindle moves)
 - (a) The control printed-circuit board is not mounted properly.
Be sure to push the βi SVSP control printed-circuit board as far as it will go. If failing to push it properly, pull it out and then push it again.
 - (b) The feedback cable of the αi position coder is broken.
Replace the feedback cable.
 - (c) Coolant enters the connector.
If coolant enters the connector, replace the connector.
 - (d) βi SVSP is faulty.
Replace the control printed-circuit board or βi SVSP.

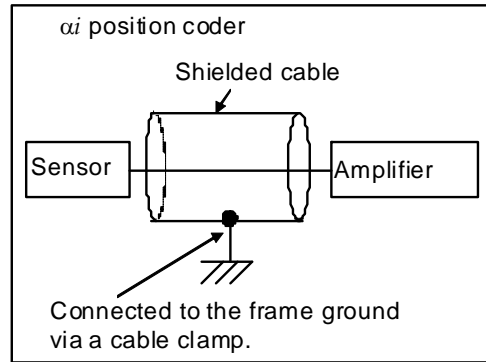

- (3) If this alarm is issued when the motor rotates
 - (a) The feedback cable is not shielded sufficiently.
Referring to the FANUC SERVO AMPLIFIER βi series DESCRIPTIONS (B-65322EN), check the shielding of the feedback cable.
 - (b) The feedback cable and the power line of the motor are bundled together.
If the feedback cable and the power line of the motor are bundled together, check the FANUC SERVO AMPLIFIER βi series DESCRIPTIONS (B-65322EN), and bundle them separately.

3.4.20 Alarm Code 29 (SP9029)

An excessive load (standard setting: load meter reading of 9.5 V) has been applied continuously for a certain period (standard setting: 30 seconds).

- (1) If this alarm is issued during cutting
 - (a) Check the load meter, and review the cutting condition.
- (2) If this alarm is issued during a stop
 - (a) The spindle is locked.
Check the sequence to see if the spindle is locked when a command for very slow movement is specified or orientation is specified for the spindle.
- (3) If the spindle does not rotate as specified (the spindle rotates at a very low speed) and this alarm is issued
 - (a) The setting of a parameter is incorrect.
Referring to "FANUC AC SPINDLE MOTOR αi series / FANUC AC SPINDLE MOTOR βi series / FANUC BUILT-IN SPINDLE MOTOR $B i$ series Parameter Manual (B-65280EN)," check the parameter for sensor setting.
 - (b) The phase sequence of the motor power line is incorrect.
Check the phase sequence of the motor power line once again.
 - (c) The feedback cable of the motor is connected incorrectly.
Check that the A/B phase signals of the spindle sensor are connected in the wrong way.
 - (d) The feedback cable of the motor or spindle sensor (or motor) is faulty.
Rotate the motor manually to see if a speed is indicated in the item of motor speed on the CNC diagnosis screen or on the spindle check board. If no speed indication is provided, replace the feedback cable or spindle sensor (or motor).
- (4) If the spindle does not rotate as specified (the spindle does not rotate at all) and this alarm is issued
 - (a) The power line is abnormal.
Check that the power line is connected correctly from the βi SVSP to the motor. If output switching and spindle switching are performed, check that the MCC on the side used is on.
 - (b) βi SVSP is faulty.
Replace the βi SVSP.

3.4.21 Alarm Code 31 (SP9031)

The motor failed to rotate as specified, and has stopped or is rotating at a very low speed.

- (1) If the motor rotates at a very low speed and this alarm is issued
 - (a) The setting of a parameter is incorrect.
Referring to "FANUC AC SPINDLE MOTOR α i series / FANUC AC SPINDLE MOTOR β i series / FANUC BUILT-IN SPINDLE MOTOR Bi series Parameter Manual (B-65280EN)," check the parameter for sensor setting.
 - (b) The phase sequence of the motor power line is incorrect.
Check if the phase sequence of the motor power line is incorrect.
 - (c) The feedback cable of the motor has a problem.
Check that the A/B phase signals of the spindle sensor are connected in the wrong way.
 - (d) The feedback cable of the motor or spindle sensor (or motor) is faulty.
Rotate the motor manually to see if a speed is indicated in the item of motor speed on the CNC diagnosis screen or on the spindle check board. If no speed indication is provided, replace the feedback cable or spindle sensor (or motor).
- (2) If the motor does not rotate at all and this alarm is issued
 - (a) The sequence for locking the spindle is incorrect.
Check the sequence to see if the spindle is locked.
 - (b) The power line is faulty.
Check that the power line is connected correctly from the β iSVSP to the motor. If output switching and spindle switching are performed, check that the MCC on the side used is on.
 - (c) β iSVSP is faulty.
Replace the β iSVSP.

3.4.22 Alarm Code 32 (SP9032)

LSI memory for serial communication is abnormal. A check is made when the power is turned on.

β iSVSP is faulty.

Replace the control printed-circuit board or β iSVSP.

3.4.23 Alarm Code 34 (SP9034)

A parameter outside the permissible range was set. Correct the parameter with either of methods (1) and (2).

- (1) Connect the spindle check board (A06B-6078-H001) to connector JY1.
On the spindle check board (A06B-6078-H001), "AL-34" and "F-xxx" are displayed alternately. "F-xxx" indicates the number of the parameter out of the permissible range. For correspondences between CNC parameter numbers and "F-xxx", refer to "Internal number F-xxx" in Appendix, "SPINDLE PARAMETER LIST", in the FANUC AC SPINDLE MOTOR α i series / FANUC AC SPINDLE MOTOR β i series / FANUC BUILT-IN SPINDLE MOTOR Bi series Parameter Manual (B-65280EN). Correct the setting of that parameter.
- (2) The parameter outside the permissible range can be identified with the status error number. The status error number of the diagnosis number, No. 710, indicates the internal number of that parameter. For correspondences between internal numbers and actual parameter numbers, refer to "Internal number F-xxx" in Appendix, "SPINDLE PARAMETER LIST", in the FANUC AC SPINDLE MOTOR α i series / FANUC AC SPINDLE MOTOR β i series / FANUC BUILT-IN SPINDLE MOTOR Bi series Parameter Manual (B-65280EN). Correct the setting of that parameter.

3.4.24 Alarm Code 35 (SP9035)

This alarm is issued only when the spindle motor β iIc series is used.

There is a large difference between the motor speed calculated from the α i position coder and the motor speed estimated with the spindle software.

(1) If an alarm is issued when a rotation command is entered

(a) Error in the α i position coder setting parameter

Correctly specify the bits representing the relationships between the direction of α i position coder rotation and that of spindle rotation and between the direction of spindle rotation and that of motor rotation.

FS0i	Description
4000#0	Spindle and spindle motor rotation directions
4001#4	Spindle sensor (α i position coder) mounting direction

(b) Invalid gear ratio parameter setting

Check to see if an incorrect gear ratio has been specified.

This value is used to convert the position coder speed to the motor speed. Be sure to specify the correct value.

FS0i	Description
4056~4059	Gear ratio between the spindle and motor

(c) Clutch/gear signal error

Make sure that the entered clutch/gear signals (CTH1A, CTH2A) are correct with respect to the actually selected gear.

	16i	#7	#6	#5	#4	#3	#2	#1	#0
First spindle	G070					CTH1A	CTH2A		

(d) Belt slippage between the spindle and spindle motor

Make adjustments so that no belt slippage will occur between the spindle and spindle motor.

(2) If an alarm is issued during a cutting operation

An overload has occurred to decrease the motor speed. Review the cutting condition.

3.4.25 Alarm Code 36 (SP9036)

The error counter overflowed.

(1) The setting of a parameter is incorrect.

(a) The gear ratio set in a parameter is incorrect.

Check if an excessively large gear ratio is set.

(b) The setting of a position gain is incorrect.

If the gear ratio data is correct, increase the position gain.

FS0i	Description
4056 to 4059	Gear ratio between the spindle and motor
4060 to 4063	Position gain at orientation
4065 to 4068	Position gain in the servo mode/spindle synchronization
4069 to 4072	Position gain in Cs contour control

(2) Sequence error

(a) Check if the motor is deactivated (by turning off SFR/SRV) in a position control mode (rigid tapping, Cs contour control, and spindle synchronous control).

3.4.26 Alarm Code 37 (SP9037)

After emergency stop signal input, the motor is accelerated without being decelerated. This alarm is issued also when the motor is not deactivated (the motor is not decelerated completely) when the acceleration/deceleration time (initial parameter setting: 10 seconds) has elapsed after emergency stop signal input.

- (a) The parameter setting of the speed detector is incorrect.
Referring to "FANUC AC SPINDLE MOTOR α i series / FANUC AC SPINDLE MOTOR β i series / FANUC BUILT-IN SPINDLE MOTOR Bi series Parameter Manual (B-65280EN)," set a correct time.
- (b) The parameter setting of an acceleration/deceleration time is not proper.
Check the parameter-set value and actual acceleration/ deceleration time, then set an actual acceleration/deceleration time plus some margin.

FS0i	Description
4082	Acceleration/deceleration time setting

3.4.27 Alarm Code 41 (SP9041)

The position where the one-rotation signal of the α i position coder is generated is incorrect.

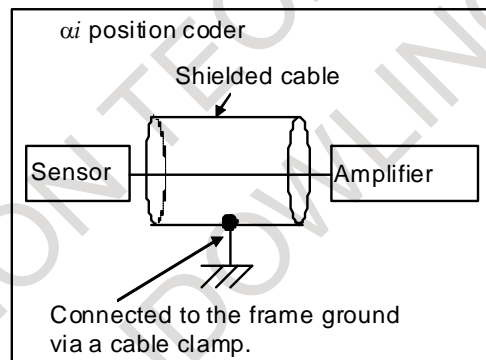

- (1) The setting of a parameter is incorrect.
Referring to " FANUC AC SPINDLE MOTOR α i series / FANUC AC SPINDLE MOTOR β i series / FANUC BUILT-IN SPINDLE MOTOR Bi series Parameter Manual (B-65280EN)," check the parameter for sensor setting.
- (2) The α i position coder is faulty.
Observe the Z signal of the α i position coder. If the signal is not generated per rotation, replace the α i position coder.
- (3) The feedback cable is not shielded sufficiently.
Referring to the FANUC SERVO AMPLIFIER β i series DESCRIPTIONS (B-65322EN), check the shielding of the feedback cable.
- (4) The feedback cable and the power line of the motor are bundled together.
If the feedback cable and the power line of the motor are bundled together, check the FANUC SERVO AMPLIFIER β i series DESCRIPTIONS (B-65322EN), and bundle them separately.
- (5) β iSVSP is faulty.
Replace the control printed-circuit board or β iSVSP.

3.4.28 Alarm Code 42 (SP9042)

The one-rotation signal of the α i position coder is not generated.

- (1) The setting of a parameter is incorrect.
Referring to "FANUC AC SPINDLE MOTOR α i series / FANUC AC SPINDLE MOTOR β i series / FANUC BUILT-IN SPINDLE MOTOR Bi series Parameter Manual (B-65280EN)," check the parameter for sensor setting.
- (2) The feedback cable or α i position coder is faulty.
Observe the Z signal of the α i position coder. If the signal is not generated per rotation, replace the feedback cable or α i position coder.
- (3) β iSVSP is faulty.
Replace the control printed-circuit board or β iSVSP.

3.4.29 Alarm Code 43 (SP9043)

The position coder signal of the master spindle used in differential spindle speed control is disconnected. Troubleshoot as in the case of alarm code 27.

3.4.30 Alarm Code 46 (SP9046)

The one-rotation signal of the position coder cannot be detected normally during thread cutting. Troubleshoot as in the case of alarm code 41.

3.4.31 Alarm Code 47 (SP9047)

The count value of α i position coder signal pulses is abnormal.

Phases A and B for the α i position coder have a feedback pulse count of 4096 p/rev per spindle rotation. The spindle control software checks the pulse counts of phases A and B equivalent to the position coder each time a one-rotation signal is generated. The alarm is issued when a pulse count beyond the specified range is detected.

- (1) If this alarm is issued when the cable is moved (as in the case where the spindle moves)
 - (a) The feedback cable of the α i position coder is broken.
Replace the feedback cable.
 - (b) Coolant enters the connector.
If coolant enters the connector, replace the connector.
- (2) In other cases
 - (a) The setting of a parameter is incorrect.
Referring to "FANUC AC SPINDLE MOTOR α i series / FANUC AC SPINDLE MOTOR β i series / FANUC BUILT-IN SPINDLE MOTOR Bi series Parameter Manual (B-65280EN)," check the parameter for sensor setting.
 - (b) The feedback cable is not shielded sufficiently.
Referring to the FANUC SERVO AMPLIFIER β i series DESCRIPTIONS (B-65322EN), check the shielding of the feedback cable.
 - (c) The feedback cable and the power line of the motor are bundled together.
If the feedback cable and the power line of the motor are bundled together, check the FANUC SERVO AMPLIFIER β i series DESCRIPTIONS (B-65322EN), and bundle them separately.
 - (d) β iSVSP is faulty.
Replace the control printed-circuit board or β iSVSP.

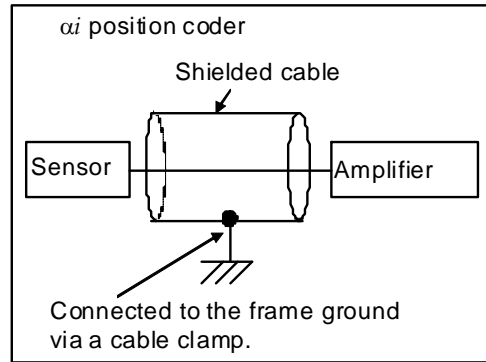

3.4.32 Alarm Code 49 (SP9049)

In differential spindle speed control, the master spindle speed as converted into a slave spindle motor speed exceeded the permissible value.

By multiplying the master spindle speed by the slave spindle-to-motor gear ratio, the master spindle speed is converted into a slave spindle motor speed. Check if this value exceeds the maximum motor speed, and operate so as not to exceed the maximum motor speed.

3.4.33 Alarm Code 50 (SP9050)

A value obtained by internal calculation in spindle synchronization exceeded the allowable range.

Troubleshooting when this alarm is issued

- (a) The setting of parameters for gear ratio setting is incorrect.
Check if an excessively large gear ratio is set.
- (b) Position gain setting limit
If correct gear ratio data is set, increase the position gain value in spindle synchronization.

FS0i	Description
4056 to 4059	Gear ratio between the spindle and motor
4065 to 4068	Position gain in the servo mode/spindle synchronization

3.4.34 Alarm Codes 52 and 53 (SP9052, SP9053)

The synchronization signal (ITP) in communication data transferred to and from the CNC stopped.

- (1) β iSVSP is faulty.
Replace the control printed-circuit board or β iSVSP.
- (2) CNC is faulty.
Replace the board or module related to the serial spindle.

3.4.35 Alarm Code 54 (SP9054)

A large current flowing in the motor for a long time was detected.
Troubleshoot as in the case of alarm code 29.

3.4.36 Alarm Code 55 (SP9055)

In spindle speed range switching control, a mismatch between the switching request signal (SPSL or RSL) and the power lead state check signal (RCH, or RCHHG) continues during motor excitation.

Troubleshooting when this alarm is issued

- (a) The magnetic contactor (switch unit) for power lead switching is faulty.
If the contact is inoperative, check the power supply of the magnetic contactor.
If the magnetic contactor is still inoperative, replace the magnetic contactor.
- (b) The I/O unit or wiring for checking the contact of the magnetic contactor is faulty.
If a defect is found in the I/O unit or wiring, replace the I/O unit or wiring.
- (c) The sequence (ladder) is incorrect.
Modify the sequence so that switching of magnetic contactor is not performed during motor excitation.

3.4.37 Alarm Code 56 (SP9056)

The βi SVSP detects the stoppage of the fan motor (internal cooling fan) for cooling the inside of the amplifier.

- (1) The internal cooling fan is not mounted correctly.
Be sure to push the βi SVSP internal cooling fan as far as it will go.
If failing to push it properly, pull it out and then push it again.
- (2) The control printed-circuit board is not mounted properly.
Be sure to push the βi SVSP control printed-circuit board as far as it will go. If failing to push it properly, pull it out and then push it again.
- (3) The internal cooling fan is abnormal.
See "REPLACEMENT OF A FANMOTOR" chapters of this maintenance manual, and replace the internal cooling fan.
- (4) βi SVSP is faulty.
Replace the control printed-circuit board or βi SVSP.

3.4.38 Alarm Code 61 (SP9061)

In the dual position feedback function, the difference in position between the semi-closed loop and the full-closed loop exceeded the preset level (No. 4354).

- (1) If this alarm is issued when the machine starts up, there may be an error in the detector-related parameters and the conversion coefficient parameters for motor edge position feedback.
Check if the settings of the motor sensor-to-spindle arbitrary gear ratios No. 4171/No. 4172 (for the High gear) and No. 4173/No. 4174 (for the Low gear) are correct. Referring to "FANUC AC SPINDLE MOTOR αi series / FANUC AC SPINDLE MOTOR βi series / FANUC BUILT-IN SPINDLE MOTOR $B i$ series Parameter Manual (B-65280EN)," check the parameter for sensor setting.
- (2) If the motor sensor-to-spindle arbitrary gear ratio is correct, the level set in No. 4354 may be too small.
- (3) If this alarm is issued with a machine that has operated normally thus far, there may occur slippage between the motor and the spindle. Check the machine.
- (4) If this alarm is issued intermittently with a machine that has operated normally thus far, the motor edge or spindle edge position feedback signal may be miscounted due to noise, etc. Take the necessary measures against noise.

3.4.39 Alarm Code 66 (SP9066)

This alarm is issued only when inter-spindle amplifier communication (connector JX4) is used. The β iSVSP does not support inter-spindle amplifier communication (connector JX4).

If this alarm is issued, the β iSVSP is faulty. Replace the β iSVSP.

3.4.40 Alarm Code 67 (SP9067)

During the execution of the spindle electronic gear box (EGB), reference position return is specified for the slave axis.

In spindle EGB mode (G81), reference position return cannot be performed. To perform reference position return, turn off EGB mode (G80) first.

3.4.41 Alarm Code 68 (SP9068)

Parameter settings contain an error.

The details of the error can be identified with the status error number. Referring to the status error number of the diagnosis number, No. 710, and Subsection 4.3.3, "Status Error Indication Function", correct the setting of the relevant parameter.

3.4.42 Alarm Code 69 (SP9069)

This alarm is issued only when the dual check safety is used.

In safety signal mode C (a guard open request is input and the protective door is open), the spindle motor speed exceeded the safety speed.

- (1) If the protective door is open, operate at the safety speed or lower.
- (2) Check the safety speed parameter.
- (3) β iSVSP is faulty.

Replace the control printed-circuit board or β iSVSP.

3.4.43 Alarm Code 70 (SP9070)

This alarm is issued only when the dual check safety is used.

The β iSVSP connection status does not match the hardware settings.

- (1) Check the β iSVSP connection and settings.
- (2) Replace the CPU card of the CNC or the β iSVSP.
- (3) Replace the β iSVSP control printed-circuit board.
- (4) The β iSVSP ID is not written.

If the amplifier ID cannot be read on the CNC screen, replace the β iSVSP.

3.4.44 Alarm Code 71 (SP9071)

This alarm is issued only when the dual check safety is used.

An error occurred in the safety parameter.

- (1) Re-set the safety parameter.
- (2) Replace the CPU card of the CNC.

- (3) βi SVSP is faulty.
Replace the control printed-circuit board or βi SVSP.

3.4.45 Alarm Code 72 (SP9072)

This alarm is issued only when the dual check safety is used.
The βi SVSP speed check results do not match the CNC speed check results.

When the alarm is issued, replace the CPU card of the CNC or the βi SVSP control printed-circuit board.

3.4.46 Alarm Code 73 (SP9073)

The motor sensor signal has a something problem.

- (1) If the alarm is issued when the motor excitation is off
 - (a) The setting of a parameter is incorrect.
Referring to "FANUC AC SPINDLE MOTOR αi series / FANUC AC SPINDLE MOTOR βi series / FANUC BUILT-IN SPINDLE MOTOR $B i$ series Parameter Manual (B-65280EN)," check the parameter for sensor setting.
 - (b) The feedback cable is disconnected.
Replace the feedback cable.
 - (c) A motor sensor (αi BZ sensor or αi MZ sensor) is not adjusted correctly.
Adjust the motor sensor signal. If the sensor signal cannot be adjusted correctly, or the sensor signal is not observed, replace the connection cable and motor sensor.
 - (d) βi SVSP is faulty.
Replace the control printed-circuit board or βi SVSP.
- (2) If this alarm is issued when the cable is moved (as in the case where the spindle moves)
 - (a) Coolant enters the connector.
If coolant enters the connector, replace the connector.
 - (b) The feedback cable is disconnected.
Replace the feedback cable.
- (3) If this alarm is issued when the motor rotates
 - (a) The shielding of the cable between the sensor and the βi SVSP is faulty.
Referring to the FANUC SERVO AMPLIFIER βi series DESCRIPTIONS (B-65322EN), check the shielding of the feedback cable.
 - (b) The feedback cable and the power line of the motor are bundled together.
If the feedback cable and the power line of the motor are bundled together, check the FANUC SERVO AMPLIFIER βi series DESCRIPTIONS (B-65322EN), and bundle them separately.

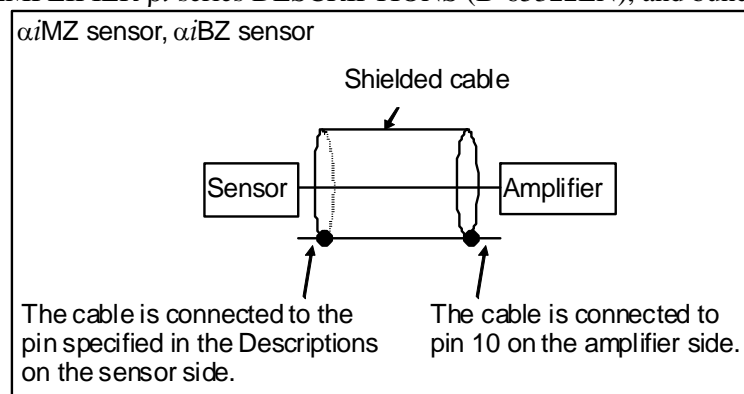

3.4.47 Alarm Code 74 (SP9074)

The CPU test did not finish normally.

β iSVSP is faulty.

Replace the control printed-circuit board or β iSVSP.

3.4.48 Alarm Code 75 (SP9075)

An error occurred in the CRC test.

β iSVSP is faulty.

Replace the control printed-circuit board or β iSVSP.

3.4.49 Alarm Code 76 (SP9076)

This alarm is issued only when the dual check safety is used.
The safety function of the spindle section is not executed.

β iSVSP is faulty.

Replace the control printed-circuit board or β iSVSP.

3.4.50 Alarm Code 77 (SP9077)

This alarm is issued only when the dual check safety is used.
The β iSVSP axis number check results do not match the CNC axis number check results.

When the alarm is issued, replace the CPU card of the CNC or the β iSVSP control printed-circuit board.

3.4.51 Alarm Code 78 (SP9078)

This alarm is issued only when the dual check safety is used.
The β iSVSP safety parameter check results do not match the CNC safety parameter check results.

When the alarm is issued, replace the CPU card of the CNC or the β iSVSP control printed-circuit board.

3.4.52 Alarm Code 79 (SP9079)

An abnormality was detected during control program initialization.

β iSVSP is faulty.

Replace the control printed-circuit board or β iSVSP.

3.4.53 Alarm Code 81 (SP9081)

The position where the one-rotation signal of the motor sensor is generated is incorrect.

- (1) If the external one-rotation signal is used
 - (a) The settings of parameters are incorrect.
Check that the gear ratio data matches the specification of the machine.

FS0i	Description
4171 4173	Denominator of gear ratio between motor sensor and spindle
4172 4174	Numerator of gear ratio between motor sensor and spindle

- (b) Slippage between the spindle and motor
Check that there is no slippage between the spindle and motor. The external one-rotation signal is not applicable to V-belt connection.
- (2) Troubleshooting in other cases
- (a) The setting of a parameter is incorrect.
Referring to " FANUC AC SPINDLE MOTOR α i series / FANUC AC SPINDLE MOTOR β i series / FANUC BUILT-IN SPINDLE MOTOR Bi series Parameter Manual (B-65280EN)," check the parameter for sensor setting.
- (b) A motor sensor (α iBZ sensor or α iMZ sensor) is not adjusted correctly.
Adjust the motor sensor signal. If the sensor signal cannot be adjusted correctly, or the sensor signal is not observed, replace the connection cable and motor sensor.
- (c) The feedback cable is not shielded sufficiently.
Referring to the FANUC SERVO AMPLIFIER β i series DESCRIPTIONS (B-65322EN), check the shielding of the feedback cable.
- (d) The feedback cable and the power line of the motor are bundled together.
If the feedback cable and the power line of the motor are bundled together, check the FANUC SERVO AMPLIFIER β i series DESCRIPTIONS (B-65322EN), and bundle them separately.
- (e) β iSVSP is faulty.
Replace the control printed-circuit board or β iSVSP.

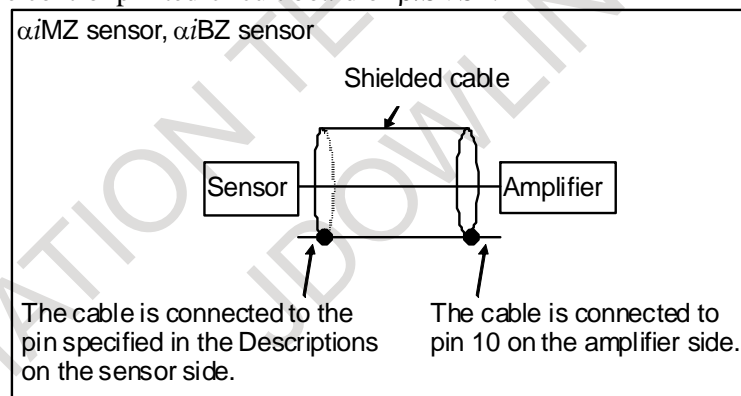

3.4.54 Alarm Code 82 (SP9082)

The one-rotation signal of the motor sensor is not generated.

- (1) If the external one-rotation signal (proximity switch) is used
- (a) The external one-rotation signal is faulty.
Check the check pin EXTSC1 on the spindle check board. If the signal is not generated per rotation, replace the connection cable and position coder.
- (2) Troubleshooting in other cases
- (a) The setting of a parameter is incorrect.
Referring to " FANUC AC SPINDLE MOTOR α i series / FANUC AC SPINDLE MOTOR β i series / FANUC BUILT-IN SPINDLE MOTOR Bi series Parameter Manual (B-65280EN)," check the parameter for sensor setting.

- (b) A motor sensor (α iBZ sensor or α iMZ sensor) is not adjusted correctly.
Adjust the motor sensor signal. If the sensor signal cannot be adjusted correctly, or the sensor signal is not observed, replace the connection cable and motor sensor.
- (c) β iSVSP is faulty.
Replace the control printed-circuit board or β iSVSP.

3.4.55 Alarm Code 83 (SP9083)

The spindle control software checks the pulse counts of phases A and B each time a one-rotation signal is generated. The alarm is issued when a pulse count beyond the specified range is detected.

- (1) If this alarm is issued when the cable is moved (as in the case where the spindle moves)
 - (a) Coolant enters the connector.
If coolant enters the connector, replace the connector.
 - (b) The feedback cable is disconnected.
Replace the feedback cable.
- (2) Troubleshooting in other cases
 - (a) The setting of a parameter is incorrect.
Referring to "FANUC AC SPINDLE MOTOR α i series / FANUC AC SPINDLE MOTOR β i series / FANUC BUILT-IN SPINDLE MOTOR Bi series Parameter Manual (B-65280EN)," check the parameter for sensor setting.
 - (b) A motor sensor (α iBZ sensor or α iMZ sensor) is not adjusted correctly.
Adjust the motor sensor signal. If the sensor signal cannot be adjusted correctly, or the sensor signal is not observed, replace the connection cable and motor sensor.
 - (c) The feedback cable is not shielded sufficiently.
Referring to the FANUC SERVO AMPLIFIER β i series DESCRIPTIONS (B-65322EN), check the shielding of the feedback cable.
 - (d) The feedback cable and the power line of the motor are bundled together.
If the feedback cable and the power line of the motor are bundled together, check the FANUC SERVO AMPLIFIER β i series DESCRIPTIONS (B-65322EN), and bundle them separately.
 - (e) β iSVSP is faulty.
Replace the control printed-circuit board or β iSVSP.

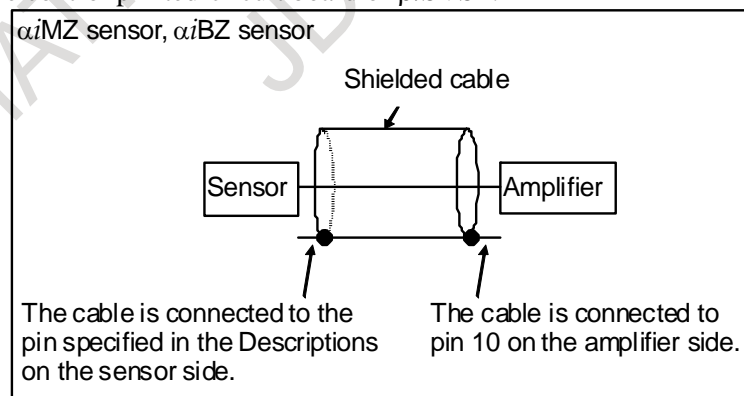

3.4.56 Alarm Code 84 (SP9084)

The spindle sensor signal has a something problem.

Refer to Alarm Code 73 for this alarm trouble shooting.

3.4.57 Alarm Code 85 (SP9085)

The one-rotation signal of the spindle sensor occurred in an incorrect location.

Refer to Alarm Code 81 for this alarm trouble shooting.

3.4.58 Alarm Code 86 (SP9086)

No spindle sensor one-rotation signal occurred.

Refer to Alarm Code 82 for this alarm trouble shooting.

3.4.59 Alarm Code 87 (SP9087)

A spindle sensor signal has a something problem.

Refer to Alarm Code 83 for this alarm trouble shooting.

3.4.60 Alarm Code 88 (SP9088)

The radiator cooling fan is stopped.

- (1) The radiator cooling fan is abnormal.
See the appropriate maintenance parts and replacement chapters of this maintenance manual, and replace the radiator cooling fan.
- (2) β iSVSP is faulty.
Replace the control printed-circuit board or β iSVSP.

3.4.61 Alarm Code 92 (SP9092)

The actual cutting feedrate of the motor exceeded the acceleration level appropriate to the velocity command.

If the alarm is issued at startup, all the causes (1) to (3) below are probable ones, but for a machine that has operated normally thus far, the cause (3) is probable.

- (1) Parameter (number of teeth of the motor sensor, number of electrodes of the motor) settings contain an error.
Referring to "FANUC AC SPINDLE MOTOR α i series / FANUC AC SPINDLE MOTOR β i series / FANUC BUILT-IN SPINDLE MOTOR Bi series Parameter Manual (B-65280EN)," check the parameters.
- (2) For BiS series spindle motor (synchronous spindle motor) drive, the settings of AMR offset-related parameters (Nos. 4084 and 4085) contain an error.
AMR offset No. 4084 is a parameter to adjust/set for each machine. If the phase relation between the magnetic pole 0-degree position of the rotor and the one-rotation signal position of the detector changes due to detector replacement, shaft slippage, and so on or if parameters are loaded from another machine, re-adjustment is necessary.
Parameter No. 4085 is for AMR offset adjustment, and must usually be "0".
- (3) The motor sensor is miscounting due to noise, etc.
Referring to the "INSTALLATION" chapter of the FANUC SERVO AMPLIFIER β i series DESCRIPTIONS (B-65322EN), and take the necessary measures against noise.

3.4.62 Alarm Codes A, A1,A2

The control program is not running.

An error was detected when the control program was running.

- (1) If this alarm is issued when the β iSVSP power is switched on
 - (a) Wrong software specification
 - (b) β iSVSP is faulty.
Replace the control printed-circuit board or β iSVSP.
- (2) If this alarm is issued when the motor is active.
 - (a) Influence by noise
Referring to the "INSTALLATION" chapter of the FANUC SERVO AMPLIFIER β i series DESCRIPTIONS (B-65322EN), check the grounding-related wiring.
If the signal cable of the spindle sensor is bundled together with the power line of the motor, bundle them separately.

3.4.63 Alarm Code b0 (SP9110)

There was an error in communication between amplifiers (spindle amplifier, servo amplifier).

- (1) Check the locations of the connectors to which the cable for communication between amplifiers is connected.
The correct status is that CXA2A and CXA2C are connected.
- (2) The cable for communication between amplifiers is faulty.
Replace the cable for communication between amplifiers.
- (3) Effect of noise
Check that the cable for communication between amplifiers is not routed together with the DC link short-circuit bar and the power line.
- (4) The β iSVSP, spindle amplifier, or servo amplifier is faulty.
Replace the control printed-circuit board of the β iSVSP, spindle amplifier, or servo amplifier; or replace the β iSVSP, spindle amplifier, or servo amplifier.

3.4.64 Alarm Codes C0, C1, and C2 (SP9120, SP9121, and SP9122)

An error occurred in serial communication data between the CNC and β iSVSP.

- (1) β iSVSP is faulty.
Replace the control printed-circuit board or β iSVSP.
- (2) CNC is faulty.
Replace the board or module related to the serial spindle.

3.4.65 Alarm Code C3 (SP9123)

In spindle switching, the switching request signal (SPSL) does not match the internal status of the motor/spindle sensor signal switching circuit (submodule SW).

The β iSVSP does not support spindle switching, so usually, this alarm is not issued, but may be detected if pin 17 of JYA2 is in contact with another pin (such as 5V).

Check the wiring of the feedback cable connected to JYA2.

3.4.66 Alarm Code C8 (SP9128)

In spindle synchronous control, the speed deviation (difference between the velocity command for the spindle edge, as calculated from the position deviation and the position gain, and the actual cutting feedrate) exceeds the alarm detection level (No. 4515).

- (1) If, during spindle synchronous control, motor excitation (SFR, SRV) is turned off and the alarm is issued immediately after it is turned on
The alarm may be issued because the spindle motor is accelerated to eliminate the position error accumulated while the motor excitation is off. Correct the sequence so that spindle synchronous control is released before motor excitation is turned off.
- (2) If the alarm is issued during cutting
 - (a) An overload may have occurred. Review the cutting conditions.
 - (b) If no overload has occurred, Review to see if the setting of the alarm detection level is appropriate.

3.4.67 Alarm Code C9 (SP9129)

In spindle synchronous control, the position deviation exceeded the alarm detection level (No. 4516).

Troubleshoot as in the case of alarm code C8.

3.4.68 Alarm Code d1 (SP9131)

An error occurred during the operation of the spindle adjustment function.
See the description of the error and the action displayed on the servo guide.

3.4.69 Alarm Code d2 (SP9132)

Communication between detector (serial) and β iSVSP is abnormal.

If the alarm is issued at startup, all the causes (1) to (5) below are probable ones, but for a machine that has operated normally thus far, the causes (3) to (5) are probable.

- (1) The setting of a parameter is incorrect.
Referring to Chapter, "Start-up" in "FANUC AC SPINDLE MOTOR α i series / FANUC AC SPINDLE MOTOR β i series / FANUC BUILT-IN SPINDLE MOTOR Bi series Parameter Manual (B-65280EN)," check the parameter for sensor setting.
- (2) The β iSVSP does not support the detector used.
Check the "Sensors" item in the FANUC SERVO AMPLIFIER α i series DESCRIPTIONS (B-65282EN).
- (3) The cable is disconnected or connected incorrectly.
Replace the cable or check the connection.
- (4) The detector is faulty.
Replace the detector.
- (5) β iSVSP is faulty.
Replace the control printed-circuit board or β iSVSP.

3.4.70 Alarm Code d3 (SP9133)

It was detected that the serial data between detector (serial) and β iSVSP that was received by the β iSVSP was destroyed by noise.

Check the shielding of the cable between detector (serial) and β iSVSP.

Check the "Sensors" item in the FANUC SERVO AMPLIFIER α i series DESCRIPTIONS (B-65282EN).

3.4.71 Alarm Code d4 (SP9134)

It was detected that the position data from the detector (serial) changed beyond the anticipated range.

If the alarm is issued at startup, both causes (1) and (2) are probable ones, but for a machine that has operated normally thus far, the cause (2) is probable.

- (1) The setting of a parameter is incorrect.

Referring to Chapter, "Start-up" in "FANUC AC SPINDLE MOTOR α i series / FANUC AC SPINDLE MOTOR β i series / FANUC BUILT-IN SPINDLE MOTOR Bi series Parameter Manual (B-65280EN)," check the parameter for sensor setting.

- (2) Check the shielding of the cable between detector (serial) and β iSVSP.

Check the "Sensors" item in the FANUC SERVO AMPLIFIER α i series DESCRIPTIONS (B-65282EN).

3.4.72 Alarm Code d6 (SP9136)

This alarm is issued only when the dual check safety is used.

The β iSVSP safety speed zero monitoring state does not match the CNC safety speed zero monitoring state.

If this alarm is issued, a hardware error is suspected. Replace the CPU card of the CNC or the β iSVSP.

3.4.73 Alarm Code d7 (SP9137)

A communication error occurred in the electronic device on the β iSVSP control circuit.

- (1) The control printed-circuit board is not mounted properly.

Be sure to push the β iSVSP control printed-circuit board as far as it will go. If failing to push it properly, pull it out and then push it again.

- (2) β iSVSP is faulty.

Replace the control printed-circuit board or β iSVSP.

3.4.74 Alarm Code d8 (SP9138)

The setting of the current limit level is outside the permissible current value range of the β iSVSP.

Check the setting of the parameter (No. 4526).

3.4.75 Alarm Code d9 (SP9139)

An error occurred in the interpolation circuit of the detector (serial).

The detection circuit of the detector (serial) is abnormal. Replace the detection circuit.

3.4.76 Alarm Code E0 (SP9140)

The number of pulses between the one-rotation signals of the detector (serial) is outside the prescribed range.

The detection circuit of the detector (serial) is abnormal. Replace the detection circuit.

3.4.77 Alarm Code E1 (SP9141)

The one-rotation signal of the detector (serial) was not generated within five rotations after the power was turned on.

If the alarm is issued at startup, all the causes (1) to (3) below are probable ones, but for a machine that has operated normally thus far, the causes (2) and (3) are probable.

- (1) The setting of a parameter is incorrect.

If the number of teeth of the detector is set incorrectly, this alarm may be issued because the actual speed does not match the speed calculated by the β iSVSP. Referring to Chapter, "Start-up" in "FANUC AC SPINDLE MOTOR α i series / FANUC AC SPINDLE MOTOR β i series / FANUC BUILT-IN SPINDLE MOTOR B i series Parameter Manual (B-65280EN)," check the parameter for sensor setting.

- (2) The detector is not adjusted correctly.

Referring to the "Sensors" item in the FANUC SERVO AMPLIFIER α i series DESCRIPTIONS (B-65282EN), adjust the sensor signal.

- (3) The detection circuit of the detector (serial) is abnormal.
Replace the detection circuit.

3.4.78 Alarm Code E2 (SP9142)

Some error or other occurred in the detector (serial). This alarm is output if a detector (serial) made by another manufacturer is used.

For details of the error, contact the manufacturer of the detector.

3.4.79 Alarm Code F8 (SP9158)

This alarm is issued only when the dual check safety is used.

The acceptance test mode state of the β iSVSP does not match the acceptance test mode setting of the CNC.

If this alarm is issued, a hardware error is suspected. Replace the CPU card of the CNC or the β iSVSP.

3.4.80 Alarm Code G6 (SP9166)

This alarm is issued only if the spindle synchronization function for guide bush is used.

The synchronization error of the guide bush axis relative to the master axis exceeds the parameter setting.

Check the parameter setting (No. 4628) of synchronization error limit. If the setting is correct, check if the β iSVSP, sensor, and so on are abnormal.

3.4.81 Alarm Code G7 (SP9167)

The ladder sequence contains an error.

The details of the error can be identified with the status error number. Referring to the status error number of the diagnosis number, No. 710, and Subsection 4.3.3, "Status Error Indication Function", correct the relevant ladder sequence.

3.4.82 Other Alarms

- (1) If 4, 11, 30, 33, 51, 58, 59, or b1 is issued on the STATUS display of the β iSVSP
This indicates that an alarm is issued in the common power supply. See Section 3.1.
- (2) CNC alarms 756 and 766 (axis number errors)
This alarm is issued only if the dual check safety function is used. If this alarm is issued, check that K90 in the figure below is mounted to the connector JA7A of the second spindle. For the first spindle only, K90 is not necessary. If the wiring is correct, replace the β iSVSP.

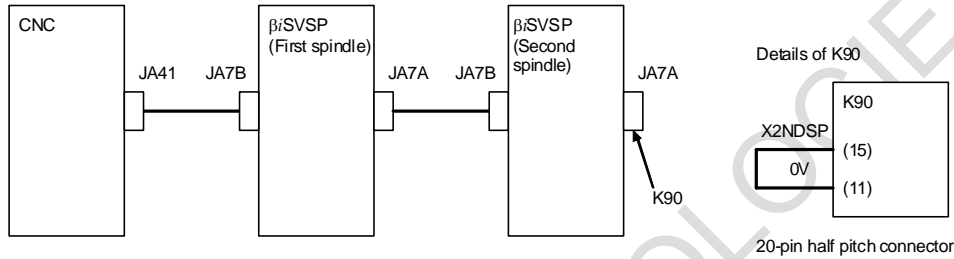

4 REPLACING SERVO AMPLIFIER COMPONENTS

This chapter describes how to replace a fan motor, absolute Pulsecoder battery, fuses, and printed-circuit board.

WARNING

Because the Servo Amplifier uses a large-capacitance electrolytic capacitor internally, the Servo Amplifier remains charged for a while even after the power is turned off. Before touching the Servo Amplifier for maintenance or other purposes, ensure your safety by measuring the residual voltage in the DC link with a tester and confirming that the charge indication LED (red) is off.

4.1 REPLACEMENT OF A FAN MOTOR

4.1.1 For the Internal Cooling Fan Motor: Model β iSVSP*-18 Only

- 1 Detach the cable and pull out the internal cooling fan motor upward.

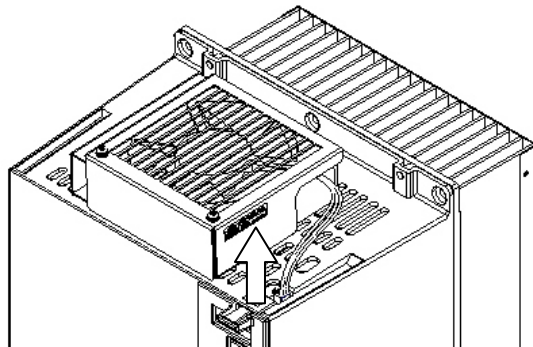

- 2 Pull the internal cooling fan motor toward the front of the servo amplifier.

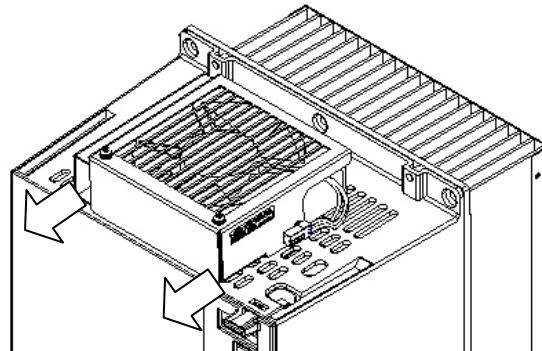

4. REPLACING SERVO

AMPLIFIER COMPONENTS TROUBLESHOOTING FOR β iSVSP

B-65325EN/02

- 3 Lift the internal cooling fan motor in a slant direction and disengage the lug.

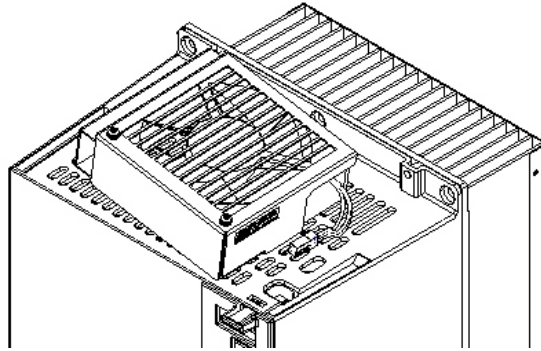

- 4 Lift the internal cooling fan motor upward.

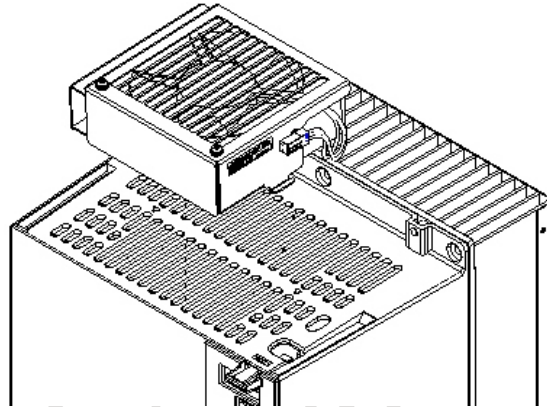

4.1.2 External Cooling Fan Motor

Remove the four sheet metal mounting screws and pull out the external cooling fan motor.

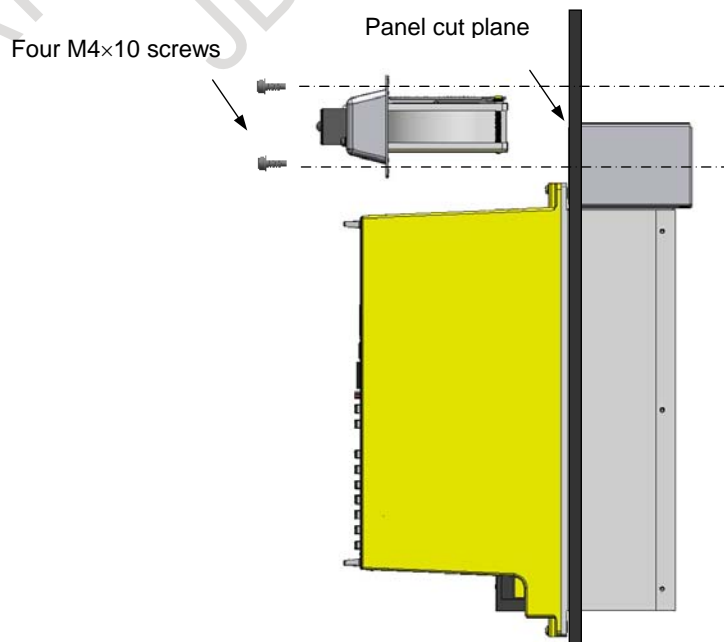

4.2 REPLACING BATTERY FOR ABSOLUTE PULSECODERS

4.2.1 Overview

- When the voltage of the batteries for absolute Pulsecoders becomes low, alarm 307 or 306 occurs, with the following indication in the CNC state display at the bottom of the CNC screen.
Alarm 307 (alarm indicating the voltage of the battery becomes low) :
The indication "APC" blinks in reversed display.
Alarm 306 (battery zero alarm) :
The indication "ALM" blinks in reversed display.
- When alarm 307 (alarm indicating the voltage of the battery becomes low) occurs, replace the battery as soon as possible. In general, the battery should be replaced within one or two weeks, however, this depends on the number of Pulsecoders used.
- When alarm 306 (battery zero alarm) occurs, Pulsecoders are reset to the initial state, in which absolute positions are not held. Alarm 300 (reference position return request alarm) also occurs, indicating that reference position return is required.
- In general, replace the batteries periodically within the service life listed below.
 - A06B-6050-K061 or D-size alkaline dry cells (LR20): Two years (for each six-axis configuration)
 - A06B-6093-K001 : One years (for each three-axis configuration)

NOTE

The above values indicate the estimated service life of batteries used with FANUC absolute Pulsecoders. The actual battery service life depends on the machine configuration based on, for example, detector types. For details, contact the machine tool builder.

4.2.2 Replacing Batteries

To prevent absolute position information in absolute Pulsecoders from being lost, turn on the machine power before replacing the battery. The replacement procedure is described below.

- <1> Ensure that the power to the servo amplifier is turned on.
- <2> Ensure that the machine is in the emergency stop state (the motor is inactive).
- <3> Ensure that the DC link charge LED of the servo amplifier is off.
- <4> Detach the old batteries and attach new ones.

The replacement of the batteries in a separate battery case and the replacement of the battery built into the servo amplifier are described below in detail.

WARNING

- 1 The absolute Pulsecoder of each of the β i series servo motors (β iS0.4 to β iS40, β iSc, and β iF) has a built-in backup capacitor. Therefore, even when the power to the servo amplifier is off and the batteries are replaced, reference position return is not required if the replacement completes within less than 10 minutes. Turn the power on and replace the batteries if the replacement will take 10 minutes or more.
- 2 To prevent electric shock, be careful not to touch metal parts in the power magnetics cabinet when replacing the batteries.
- 3 Because the servo amplifier uses a large-capacitance electrolytic capacitor internally, the servo amplifier remains charged for a while even after the power is turned off. Before touching the servo amplifier for maintenance or other purposes, ensure your safety by measuring the residual voltage in the DC link with a tester and confirming that the charge indication LED (red) is off.

4. REPLACING SERVO

⚠ WARNING

- 4 Be sure to replace the batteries with specified ones. Pay attention to the battery polarity. If a wrong type of battery is used or a battery is installed with incorrect polarity, the battery may overheat, blow out, or catch fire, or the absolute position information in the absolute Pulsecoders may be lost.
- 5 Ensure that the battery connector is inserted in the correct position.

4.2.3 Replacing the Batteries in a Separate Battery Case

Use the following procedure to replace the batteries in the battery case.

- <1> Loosen the screws on the battery case and detach the cover.
- <2> Replace the batteries in the case (pay attention to the polarity).
- <3> Attach the cover to the battery case.

Battery case (with a cover)
A06B-6050-K060

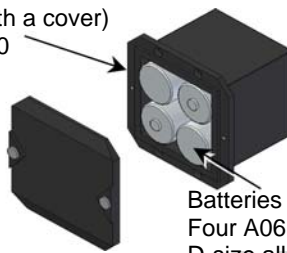

Batteries
Four A06B-6050-K061 batteries or
D-size alkaline dry cells

⚠ CAUTION

- 1 Four D-size alkaline dry cells (LR20) that are commercially available can be used as batteries. A set of four A06B-6050-K061 batteries is optionally available from FANUC.
- 2 Replace all the four batteries with new ones. If old and new batteries are mixed, the absolute position information in the absolute Pulsecoders may be lost.

4.2.4 Replacing the Battery Built into the Servo Amplifier

Use the following procedure to replace the special lithium battery.

- <1> Detach the battery case.
- <2> Replace the special lithium battery.
- <3> Attach the battery case.

⚠ CAUTION

- 1 Purchase the battery from FANUC because it is not commercially available. It is therefore recommended that you have a backup battery.
- 2 When the built-in battery is used, do not connect BATL (B3) of connector CXA2C/CXA2A. Also, do not connect two or more batteries to the same BATL (B3) line. These connections are dangerous because battery output voltages may be short-circuited, causing the batteries to overheat.
- 3 Install the battery in the servo amplifier in a direction that allows slack in the cable. If the battery cable is under tension, a bad connection may occur.
- 4 If the +6 V pin and 0 V pin of CX5X are short-circuited, the battery may overheat, blow out, or catch fire, or the absolute position information in the absolute Pulsecoders may be lost.
- 5 When inserting the connector, align it to the connector pins.

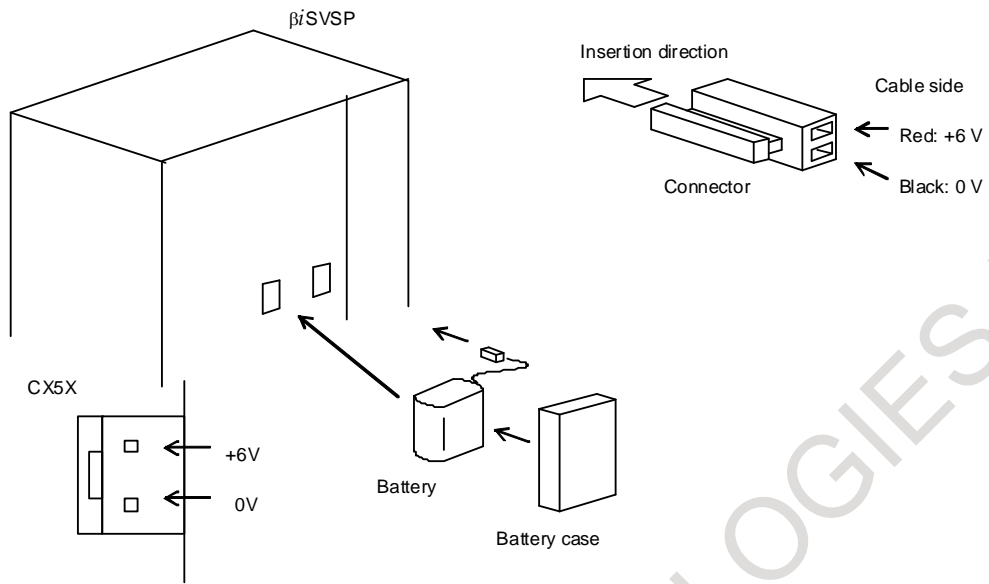

[Battery sets and outlines]

Battery ordering drawing number	Manufacturer model number	Battery case ordering drawing number	Outline
A06B-6114-K504	BR-2/3AGCT4A (Panasonic)	A06B-6114-K506	

Used batteries

Old batteries should be disposed as "INDUSTRIAL WASTES" according to the regulations of the country or autonomy where your machine has been installed.

4.2.5 Notes on Replacing a Battery (Supplementary Explanation)

4.2.5.1 Battery connection modes

The battery for the absolute Pulsecoder can be connected using [Connection method 1] and [Connection method 2] explained below.

For details, refer to "Connecting the Battery" in the FANUC SERVO AMPLIFIER β i Series Descriptions (B-65322EN).

[Connection method 1] Method of supplying battery power from one battery to multiple β iSVSP amplifiers

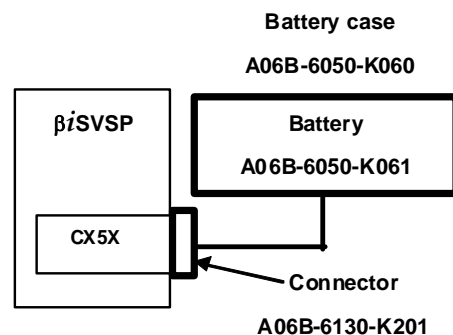

- If a low battery voltage or a battery voltage of 0 V is indicated by an APC (absolute Pulsecoder) alarm, replace the battery. If a battery voltage of 0 V is indicated, you need to make a zero point return.
- The absolute Pulsecoder of the β iS series servo motor (β iS 0.4 to β iS 40, β iSc, and β iF) is incorporated with a backup capacitor as standard. This backup capacitor enables an absolute position detection to be continued for about 10 minutes. Therefore, no zero point return need be performed if the time during which servo amplifier power is kept off for battery replacement is within 10 minutes. The Pulsecoder of the β series servo motors and some of the β iS series servo motors (β iS 0.2 to β iS0.3) does not include a backup capacitor. Be careful when replacing the battery for this Pulsecoder. See Subsection 4.2.5.2, "Connecting the battery for the β series motor" in Part II, "TROUBLESHOOTING FOR β iSV" at the end of this section for details.
- The battery service life is about two years for the β i series servo motors (β iS 0.4 to β iS 40, β iSc, and β iF) if servo motors for six axes are connected. For the β series servo motors and some of the β iS series servo motors (β iS 0.2 to β iS0.3), the battery service life is about one year. FANUC recommends that you replace the batteries periodically according to the battery service life.
- The battery unit consists of four R20 alkaline batteries. Commercial batteries can be used in the battery unit. The optional battery offered by FANUC is A06B-6050-K061.

⚠ WARNING

- 1 Do not connect more than one battery to the same BATL (B3) line. If the output voltage is different between the batteries, they may be short-circuited, resulting in the batteries becoming very hot.
- 2 Install the battery with correct polarity. If the battery is installed with incorrect polarity, it may overheat, blow out, or catch fire.

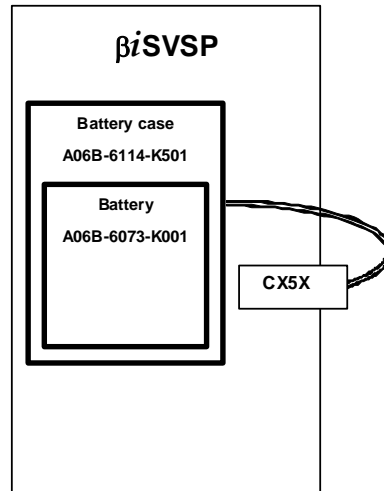
[Connection method 2] Method of building a built-in battery into each β iSVSP

- If a low battery voltage or a battery voltage of 0 V is indicated by an APC (absolute Pulsecoder) alarm, replace the battery (A06B-6073-K001). If a battery voltage of 0 V is indicated, you need to make a zero point return.
- The absolute Pulsecoder of the β i series servo motor (β iS 0.4 to β iS 40, β iSc, and β iF) is incorporated with a backup capacitor as standard. This backup capacitor enables an absolute position detection to be continued for about 10 minutes. Therefore, no zero point return need be performed if the time during which servo amplifier power is kept off for battery replacement is within 10 minutes.
The Pulsecoder of the β series servo motors and some of the β iS series servo motors (β iS 0.2 to β iS0.3) does not include a backup capacitor. Be careful when replacing the battery for this Pulsecoder. See Subsection 4.2.5.2, “Connecting the battery for the β series motor” in Part II, “TROUBLESHOOTING FOR β iSV” at the end of this section for details.
- The battery service life is about two years for the β i series servo motors (β iS 0.4 to β iS 40, β iSc, and β iF) if servo motors for three axes are connected.
FANUC recommends that you replace the batteries periodically according to the battery service life.
- The built-in batteries are not commercially available. They must be purchased from FANUC. So, FANUC recommends that you keep spares.

⚠ WARNING

- 1 When using the built-in batteries (A06B-6073-K001), do not connect them to the BATL(B3) of connector CXA2C.
The output voltages from different batteries may be short-circuited, resulting in the batteries becoming very hot.
- 2 Do not connect more than one battery to the same BATL(B3) line. If the output voltage is different between the batteries, they may be short-circuited, resulting in the batteries becoming very hot.
- 3 Install the battery with correct polarity. If the battery is installed with incorrect polarity, it may overheat, blow out, or catch fire.

4.2.6 Notes on Attaching Connectors

If an excessive strain is applied to a connector when it is inserted or removed, a poor contact may result. When inserting and removing the battery connector, therefore, be careful not to apply an excessive wrenching force to it; just follow the instructions given in the following table.

(1) Attaching connectors

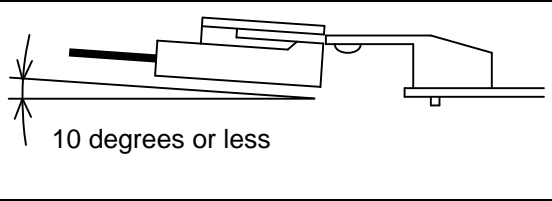
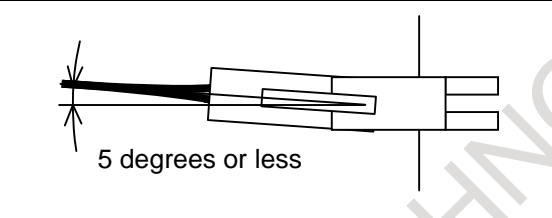
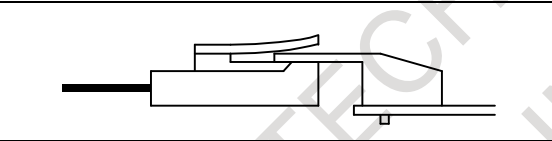
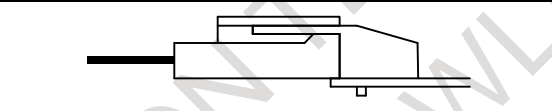
<1>		Check the attachment position.
<2>	 <p>10 degrees or less</p>	Plug the cable connector while raising it slightly.
<5>	 <p>5 degrees or less</p>	Here, the angle of the cable connector to the horizontal must be 5 degrees or less.
<3>		After passing the lock pin, insert the connector straight.
<4>		The attachment of the connector is completed.

(2) Detaching the connector

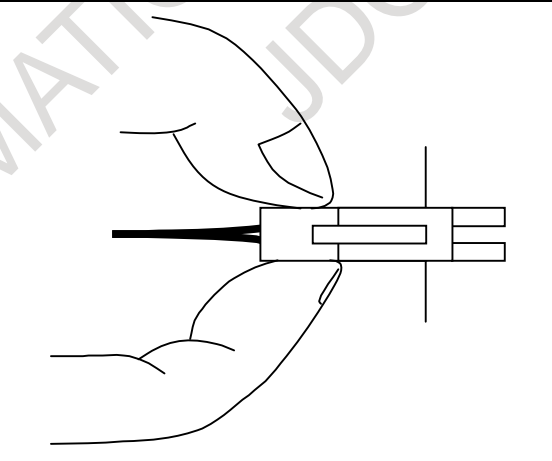
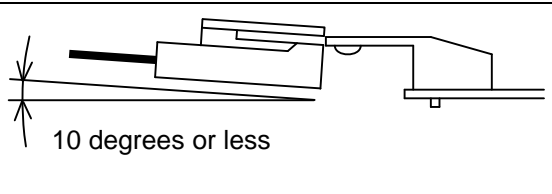
<1>		Hold both the sides of the cable insulator and the cable, and pull them horizontally.
<2>	 <p>10 degrees or less</p>	Pull out the cable side while raising it slightly.

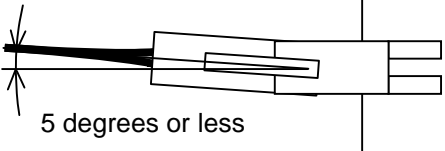
<3>		<p>Here, the angle of the cable to the horizontal must be 5 degrees or less.</p>
-----	---	--

4.3 HOW TO REPLACE THE FUSES AND PRINTED CIRCUIT BOARDS

4.3.1 How to Replace the Fuses and Printed Circuit Boards

In the β iSVSP, a printed circuit board can be removed and inserted from the front of the servo amplifier.

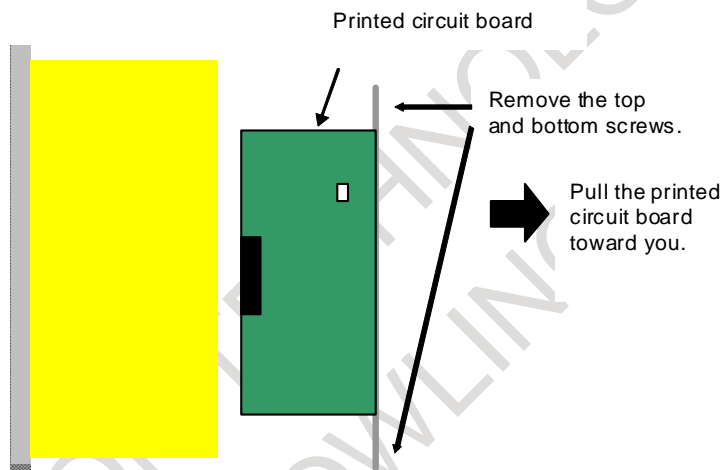

Fuse specification

Symbol	Ordering number
FU1	A60L-0001-0290/LM32C

When replacing the fuse, be sure to confirm the fuse specification.
 Insert the fuse in the fuse socket securely.

When replacing the printed circuit board, fasten the upper and lower screws securely.
 Poor connector contact may cause an unpredictable problem.

4.3.2 Fuse Locations

There is one fuse on the β iSVSP printed-circuit board.

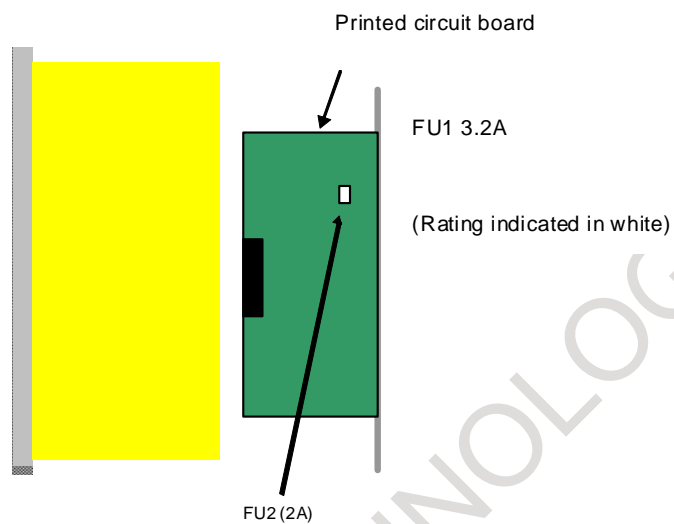

V. MOTOR/DETECTOR/AMPLIFIER PREVENTIVE MAINTENANCE

JR AUTOMATION TECHNOLOGIES INC*
JDOWLING

JR AUTOMATION TECHNOLOGIES INC*
JDOWLING

1 MOTOR/DETECTOR/AMPLIFIER PREVENTIVE MAINTENANCE

This chapter describes preventive maintenance of motors, detectors, and amplifiers that is to be performed by the customer the machine uses.

Contents

1.1	LIST OF MANUALS RELATED TO MOTORS AND AMPLIFIERS.....	148
1.2	PREVENTIVE MAINTENANCE OF MOTORS AND DETECTORS.....	149
1.2.1	Warnings, Cautions, and Notes on Preventive Maintenance of Motors and Detectors	149
1.2.2	Preventive Maintenance of a Motor (Common to All Models)	151
1.2.2.1	Main inspection items	151
1.2.2.2	Periodic cleaning of a motor.....	154
1.2.2.3	Notes on motor cleaning.....	154
1.2.2.4	Notes on the cutting fluid (informational).....	154
1.2.3	Preventive Maintenance of a Linear Motor	155
1.2.3.1	Appearance inspection of the linear motor (magnet plate).....	155
1.2.4	Maintenance of a Detector	155
1.2.4.1	Alarms for built-in detectors (αi and βi Pulsecoders) and troubleshooting actions.....	156
1.2.4.2	Alarms for separate detectors and troubleshooting actions	156
1.2.4.3	Detailed troubleshooting methods	158
1.2.4.4	Maintenance of $\beta i S$ servo motor ($\square 40$ and $\square 60$) Pulsecoders	159
1.3	PREVENTIVE MAINTENANCE OF SERVO AMPLIFIERS.....	160
1.3.1	Warnings, Cautions, and Notes on Operation of Servo Amplifiers.....	160
1.3.2	Preventive Maintenance of a Servo Amplifier.....	163
1.3.3	Maintenance of a Servo Amplifier.....	164
1.3.3.1	Display of the servo amplifier operation status	164
1.3.3.2	Replacement of a fan motor	164
1.4	REPLACING BATTERY FOR ABSOLUTE PULSECODERS.....	164

1.1 LIST OF MANUALS RELATED TO MOTORS AND AMPLIFIERS

Details of individual motors and amplifiers are described in the manuals listed in the table below. Before performing periodic inspection or any other maintenance work, consult with the machine tool builder and, if necessary, obtain the latest version of the corresponding manual shown in the list. The information about the specifications of each device, such as the weight and winding resistance value, is given in the relevant "DESCRIPTIONS" manual.

Manual name	Type of manual	Specification number
FANUC AC SERVO MOTOR αi series	DESCRIPTIONS	B-65262EN
FANUC AC SERVO MOTOR βi series	DESCRIPTIONS	B-65302EN
FANUC SYNCHRONOUS BUILT-IN SERVO MOTOR DiS series	DESCRIPTIONS	B-65332EN
FANUC LINEAR MOTOR LiS series	DESCRIPTIONS	B-65382EN
FANUC AC SPINDLE MOTOR αi series	DESCRIPTIONS	B-65272EN
FANUC AC SPINDLE MOTOR βi series	DESCRIPTIONS	B-65312EN
FANUC BUILT-IN SPINDLE MOTOR BiI series	DESCRIPTIONS	B-65292EN
FANUC SYNCHRONOUS BUILT-IN SPINDLE MOTOR BiS series	DESCRIPTIONS	B-65342EN
FANUC - NSK SPINDLE UNIT series	DESCRIPTIONS	B-65352EN
FANUC SERVO AMPLIFIER αi series	DESCRIPTIONS	B-65282EN
FANUC SERVO AMPLIFIER βi series	DESCRIPTIONS	B-65322EN
FANUC AC SERVO MOTOR αi series FANUC AC SERVO MOTOR βi series FANUC LINEAR MOTOR LiS series FANUC SYNCHRONOUS BUILT-IN SERVO MOTOR DiS series	PARAMETER MANUAL	B-65270EN
FANUC AC SPINDLE MOTOR $\alpha i/\beta i$ series BUILT-IN SPINDLE MOTOR BiI series	PARAMETER MANUAL	B-65280EN
FANUC AC SERVO MOTOR αi series AC SPINDLE MOTOR αi series SERVO AMPLIFIER αi series	MAINTENANCE MANUAL	B-65285EN
FANUC AC SERVO MOTOR βi series AC SPINDLE MOTOR βi series SERVO AMPLIFIER βi series	MAINTENANCE MANUAL	B-65325EN
FANUC SERVO AMPLIFIER βi series I/O Link Option	MAINTENANCE MANUAL	B-65395EN
FANUC SERVO GUIDE	OPERATOR'S MANUAL	B-65404EN
FANUC AC SERVO MOTOR $\alpha is/\alpha i/\beta is$ series	SERVO TUNING PROCEDURE (BASIC)	B-65264EN

1.2 PREVENTIVE MAINTENANCE OF MOTORS AND DETECTORS

1.2.1 Warnings, Cautions, and Notes on Preventive Maintenance of Motors and Detectors

This subsection contains the safety precautions for motor and detector preventive maintenance, which are classified into "warnings", "cautions", and "notes" according to their bearing on safety. Make sure that you understand and comply with these precautions when carrying out the maintenance work.

WARNING

- **Make sure that you are safely dressed and have a safe working environment when performing preventive maintenance for a motor.**
 - Be dressed safely, e.g. by wearing gloves and safety shoes, to protect against injury due to an edge or protrusion and electric shock.
 - Have the work done by more than one person, where possible, so that immediate action can be taken if an accident occurs when handling a motor.
 - A motor is heavy. When moving it, use a crane or other appropriate equipment to protect against injury. For information about the weight of the motor, refer to its DESCRIPTIONS manual (shown earlier).
 - Clothes or fingers can be caught in a rotating motor or come into contact with a moving part of it. Standing in the direction of motor rotation (direction of motion) can pose a risk of injury. Before rotating a motor, check that there is no object that is thrown away by motor rotation.
- **Be careful about electric shock, fire, and other accidents.**
 - Do not handle a motor with a wet hand.
 - To prevent electric shock, make sure that no conductive object, such as a terminal, is exposed when the motor is powered on.
 - Before touching a motor or any surrounding part, check that the power is shut off and take appropriate safety precautions.
 - High voltage remains across power line terminals of a motor even after the power is shut off (for at least twenty minutes). Do not touch a motor in such a condition or connect it to other equipment.
 - A loose or disconnected terminal, short-circuited terminals, or a terminal connected to the ground can cause overheating, spark, fire, or damage to the motor. Take appropriate precautions to prevent these accidents.
 - When placed near any inflammable object or material, a motor can be ignited, catch fire, or explode. Avoid placing it near such object or material.
- **Do not disassemble or modify a motor.**

Motors such as linear motors, synchronous built-in servo motors, and synchronous built-in spindle motors contain very strong magnets. If electronic medical apparatus comes near, these motors can cause the apparatus to malfunction, potentially putting the user's life in danger. Also, disassembling or modifying a motor can cause a failure, regardless of the type of motor. Do not disassemble or modify a motor in any way not specified by FANUC.

 **CAUTION**

- **Ensure that the specified cooling conditions are met.**
If the specified cooling conditions are not met (the motor is insufficiently or excessively cooled), the motor can fail. Problems that can cause a motor failure, such as liquid piping clog, leakage, and fan motor trouble, should be eliminated through periodic inspection. Do not drive the motor when the cooling system is in an abnormal condition.
- **Do not change the system configuration.**
Do not change the configuration of the system when it is running normally. Doing so can cause an accident or failure. If you disconnect a cable for maintenance or some other purpose, take an appropriate measure, such as putting a mark on it, to ensure you can restore the original state.
- **Use the tapped holes of a motor only to move the motor.**
Do not use the tapped holes of a motor to lift or move any other object along with the motor. Doing so can damage the motor. Depending on the type of motor, the place and direction in which the motor can be lifted may be predetermined. For details, refer to the DESCRIPTIONS manual of the motor (shown earlier).
- **Do not touch a motor when it is running or immediately after it stops.**
A motor may get hot when it is running. Do not touch the motor before it gets cool enough. Otherwise, you may get burned.

NOTE

- **Do not remove a nameplate from a motor.**
The nameplate is used to identify the motor during maintenance work. If a nameplate comes off, be careful not to lose it.
- **Do not step or sit on a motor, and avoid applying shock to a motor.**
Any of these acts can deform or break the motor or affect its component, crippling the normal motor operation. Do not put a motor on top of another motor.
- **Comply with the specified conditions when conducting an electric test (winding resistance test, insulation resistance test, etc.) for a motor or other device or supplying power.**
 - Conduct an electric test according to the specified method. Conducting such a test by any method that is not specified can damage the motor.
 - Do not conduct a dielectric strength test or insulation test for a Pulsecoder or other detector, or do not apply a commercial power source voltage. Doing so can destroy the internal elements.
- **Perform preventive maintenance (inspection of the external appearance, measurement of winding resistance, insulation resistance, etc.) and cleaning on a regular basis.**
To use a motor safely throughout its entire service life, perform preventive maintenance and cleaning on a regular basis. Be careful, however, because excessively severe inspection (dielectric strength test, etc.) can damage its windings. For information about winding resistance values, refer to the DESCRIPTIONS manual of the motor (its specification number is shown in this manual). Information about insulation resistance is given later in this manual.

NOTE

- This manual is focused on the preventive maintenance work to be performed for a single FANUC motor or detector alone. The information contained herein may not apply depending on the type or configuration of the machine. When reading this manual, refer to the manual of the machine as well. If you have any questions or doubts, do not act on your own; please contact the machine tool builder or FANUC.
- For detailed information about a motor, see the manual list shown earlier and, if necessary, obtain the latest version of the corresponding manual.

1.2.2 Preventive Maintenance of a Motor (Common to All Models)

This subsection describes the common preventive maintenance items to be handled regardless of the model of the motor. For the items specific to a particular motor model, see one of the subsequent subsections that pertains to that particular motor model.

⚠ CAUTION

- The preventive maintenance method differs from machine to machine in many respects. Depending on the machine in use, it may be difficult for the user to perform periodic inspection or cleaning. If you are not sure about anything as to preventive maintenance, consult with the machine tool builder and ensure that you can perform periodic inspection and cleaning.
- The machine should be used within the scope of specification defined by the machine tool builder. Using the machine in any way that is outside the specified scope can reduce the motor's service life or cause a failure.

1.2.2.1 Main inspection items

The following table summarizes the main inspection items for a motor. If any of these items **is found to be abnormal, stop the use of the machine immediately and fix the abnormal part** by repairing or replacing it. At the same time, **identify and remove the cause and take a measure to prevent its recurrence**. If it is difficult to take a preventive measure or to prevent its recurrence, consult with the machine tool builder or FANUC.

Appearance of the motor	Crack or deformation	<ul style="list-style-type: none"> - Check the motor for any scar, crack, deformation, bulge, etc. - If the interior of the motor is visible or there is interference with a peripheral component, it is imperative to replace the motor or the peripheral component. - A light peel-off or scar of the surface may be repairable; consult with FANUC.
	Wet or dirty part	<ul style="list-style-type: none"> - If you find any wet or dirty part, clean it immediately. - A preventive measure is needed if the part in question remains wet continually due to cutting fluid or dew condensation.
Operating conditions	Temperature, humidity, etc.	<ul style="list-style-type: none"> - Comply with the operating conditions of the machine. For details of the operating conditions of a specific motor, refer to the corresponding DESCRIPTIONS manual. Generally, the ambient temperature should be 0°C to 40°C (or 30°C for a spindle unit) and dew condensation is not allowed. In a place subject to severe vibration, the components of the motor may be broken.

Connection state	Cable	<ul style="list-style-type: none"> - Check for any cable sheath damage, exposed conductor, damaged conduit or cable bearing, abnormal bending, loose terminal, etc. - If there is any trace of fluid flowing, the fluid may have entered the inside of the motor or connector. It is necessary to make a check and take a measure to prevent recurrence.
	Connector/terminal	<ul style="list-style-type: none"> - Check for any cracked, exposed, loose, or removed terminal or connector, etc. - Fluid causes a failure; be sure to remove fluid. - A scarred or damaged connector or terminal needs to be replaced. In the case of a resin molded motor, such as a linear motor, the motor needs to be replaced.
Operation of the motor	Noise/vibration	<ul style="list-style-type: none"> - Check for any abnormal noise or vibration not only when the motor is running (the spindle is rotating) but also when it is stopped. - Abnormal noise heard when the motor is rotating indicates an abnormality of the bearing or a failure inside the motor. - If abnormal noise is generated from the connection section of a Spindle Amplifier, check the following items: Belt connection: Check whether the belt tension is appropriate. Gear connection: Check whether an appropriate value is set for the gear backlash. Coupling connection: Check whether the coupling is free from deformation, crack, and looseness.
	Movement	<ul style="list-style-type: none"> - Check that the motor operates normally and smoothly. - If the circuit breaker trips at the same time the motor starts to operate, it indicates abnormal motor windings.
	Heat	<p>Check whether the motor does not overheat during the normal operation cycle.</p> <p>Note: While the motor is running or immediately after it is stopped, the motor surface may become very hot. Instead of touching the motor directly by hand, use a thermolabel, surface thermometer, etc.</p>
Electric characteristics of the motor	Winding resistance	<p>If the resistance value exceeds the specified range, the motor needs to be replaced.</p> <p>Note: When conducting winding resistance measurement, disconnect the motor from the amplifier and measure the resistance at the power line or connector closest to the motor.</p>
	Insulation resistance	<p>For the measuring method and judgment criteria, see the table that follows.</p>
Cooling fan (for a model with a fan motor)	Noise/vibration	<ul style="list-style-type: none"> - Check that the fan blows air normally without causing abnormal noise or vibration. - If abnormal noise is heard even when the motor is stopped, it indicates a fan motor failure.
	Movement	<ul style="list-style-type: none"> - If the power is on and if the fan does not operate or the fan blades cannot be moved even manually, or if the fan blades are rotating but no cooling wind is blown out, the fan motor may have cutting chips or sludge accumulated in it and needs to be cleaned. - If the fan does not operate normally for any other reason, the fan motor needs to be replaced.

Forcible cooling unit (when using an external cooling unit such as liquid cooling unit)	Dew condensation (over-cooling)	<ul style="list-style-type: none"> - Check that forcible cooling does not cause dew condensation on the motor surface. Dew condensation is likely particularly when the cooling unit continues to run after the machine is stopped. In that case, be sure to make this check. - Dew condensation or water drop on the motor surface can reduce the motor's service life. It is necessary to wipe it dry and take a measure to prevent recurrence.
	Liquid leakage/clog	<ul style="list-style-type: none"> - Check the cooling pipe for leakage or clog. Do not drive the motor unless the leakage or clog is fixed. - Liquid leakage from a spindle motor with a through hole indicates a failure of the coolant joint. In this case, the joint needs to be replaced. - In the case of liquid leakage from a linear motor (coil slider), the linear motor (coil slider) needs to be replaced. - If the motor gets wet due to liquid leakage or any other cause, it is necessary to clean and dry the motor and perform electric characteristic checks (winding resistance/insulation resistance).

Insulation resistance measurement

The following table shows the judgment criteria to be applied when measuring insulation resistance between winding and frame using a megohmmeter (500 VDC).

Insulation resistance	Judgment
100M Ω or higher	Acceptable
10M to 100M Ω	The winding has begun deteriorating. There is no problem with the performance at present. Be sure to perform periodic inspection.
1M to 10M Ω	The winding has considerably deteriorated. Special care is in need. Be sure to perform periodic inspection.
Lower than 1M Ω	Unacceptable. Replace the motor.

If insulation resistance drops sharply during a short period of time or if the circuit breaker trips, the cutting fluid or other foreign matter may have entered the inside of the motor or cable. In that case, contact the machine tool builder or FANUC for instructions.

CAUTION

- Let the motor dry and cool to room temperature before winding or insulation resistance is measured. Otherwise, not only an accurate measurement cannot be performed but also the motor may be damaged.
- The winding or insulation resistance measurement should be performed on the motor alone, with its power line disconnected.
Measuring insulation resistance with the motor connected to the amplifier may damage the amplifier.
- During insulation resistance measurement, applying voltage to the motor for a long time may further deteriorate the insulation of the motor. Therefore, the measurement of insulation resistance should be performed in a minimum amount of time where possible.
- When disconnecting the power line and other cables, take an appropriate measure, such as labeling, to ensure that they can be restored to their original state.

1.2.2.2 Periodic cleaning of a motor

Periodic cleaning is necessary to remove an accumulation of cutting chips or sludge that may eventually cause a failure. Also, leaving the cutting fluid or other chemical substance attached for a long time can reduce the motor's service life substantially. When forcible cooling is provided by a liquid or air cooling unit, check the unit for pipe clog, fan failure, etc. and perform cleaning periodically to ensure that the coolant flows smoothly and that the motor is cooled properly.

⚠ WARNING

Depending on the type of motor, the handling may involve a risk and require safety education in advance. Also, some machines are difficult for users to clean on their own. If you are to clean the motor, consult with the machine tool builder in advance with regard to the cleaning method, safety education, etc.

1.2.2.3 Notes on motor cleaning

A motor is an electric product, which is incompatible with most kinds of fluid. When removing cutting chips, sludge, cutting fluid, etc. during cleaning, note the following.

Note on cleaning	Measure
Do not sprinkle fluid. Do not wash by submerging.	Do not sprinkle or spray detergent or any other fluid over the motor (including its peripheral components), or do not wash the motor by submerging it in such fluid. When cleaning the motor, use a cloth moistened with a small amount of neutral detergent so that the fluid does not enter the inside the motor.
Do not use solvent.	Solvent may damage the motor; do not use one. If the dirt is difficult to remove with neutral detergent, use a cloth moistened with a small amount of industrial alcohol (e.g., IPA). Be careful, however, because rubbing with force or repeatedly may damage the coated or resin surface.
Do not leave the motor wet or moistened.	If the motor is wet or moistened after cleaning, dry it before supplying power and before performing electric tests. When drying the motor in an oven, make sure that the temperature is below 40°C and that hot air does not blow directly against the motor.

1.2.2.4 Notes on the cutting fluid (informational)

Depending on the type of cutting fluid used, the motor and amplifier may be affected greatly. Take due care because, even if you ensure that they do not come into direct contact with the fluid, a mist or atmosphere of the fluid can cause the problems described below.

Type of cutting fluid requiring care	Expected problem
Cutting fluid containing highly active sulfur	Some types of cutting fluid contain highly active sulfur. If such cutting fluid enters the inside of the motor or amplifier, it causes copper, silver, and other kinds of metal to corrode, leading to a component failure.
Synthetic cutting fluid with high permeability	Some types of cutting fluid containing such substance as polyalkylene glycol have very high permeability. Such cutting fluid permeates into the inside of the motor, causing insulation deterioration or component failure.
Highly alkaline, water-soluble cutting fluid	Some types of cutting fluid that enhance their alkaline property using such substance as alkanolamine remain highly alkaline - pH10 or higher - when diluted. If such cutting fluid is left attached for a long time, its chemical change will deteriorate the resin and other materials of the motor and amplifier.

Other types of cutting fluid not mentioned above may cause various unexpected problems. If any problem arises for which the cutting fluid is thought to be responsible, consult with the machine tool builder or FANUC.

1.2.3 Preventive Maintenance of a Linear Motor

The magnet plate of a linear motor contains very strong magnets. When performing the maintenance work, make sure all those engaged in the work fully understand the potential risks involved.

⚠ WARNING

- The FANUC linear motors use very strong magnets. Improper handling of the motor is very dangerous and can lead to a serious accident. Particularly, a person wearing a pacemaker or other medical apparatus should stay away from the linear motor; otherwise, the apparatus may malfunction, potentially resulting in a life-threatening accident.
- Those who will come near or touch a linear motor for maintenance work should receive safety education in advance. For details, contact the machine tool builder or FANUC.

1.2.3.1 Appearance inspection of the linear motor (magnet plate)

Perform an appearance inspection as well during cleaning or other maintenance work. A crack, chip, deformation, or any other abnormality in appearance of the motor can lead to a serious failure in the not-so-distant future. If you find any such abnormality, be sure to report it to the machine tool builder. A scratch or other slight scar on the motor surface can also be a sign of future trouble and needs to be addressed with care. Some suggested appearance inspection items for the magnet plate are described below.

* For the coil slider (the side to which the power line is connected), see "Main inspection items" earlier in this manual.

Appearance of the magnet plate (which may have a stainless cover)

Appearance inspection item	Measure
Crack or chip in the magnet plate resin Deformation or bulge of the magnet plate or softening of the resin	The magnet plate needs to be replaced. If unattended, it can cause trouble in the not-so-distant future. If the problem is extremely minor, consult with the machine tool builder or FANUC.
The magnet is exposed, or the resin or magnet is floating	The magnet plate needs to be replaced urgently.
Scratch on the magnet plate	Foreign matter may have entered into the motor, or interference between parts is likely. It is necessary to eliminate the cause and take a measure to prevent recurrence.
Floating, bulging, or deformed stainless cover	The cover or magnet plate needs to be replaced.

1.2.4 Maintenance of a Detector

⚠ CAUTION

- Detectors such as Pulsecoders are precision equipment. When handling a detector, avoid applying shock to it. Also, exercise care to prevent cutting powder, dust, cutting fluid, or other foreign matter from attaching to it.
- Make sure that all connectors are connected properly and securely. A connection failure can cause an alarm or some other problem.
- If the detector and/or connectors are not installed securely, cutting fluid may enter the inside of the detector, making it necessary to replace the detector. In that case, contact the machine tool builder or FANUC.

NOTE

If you use a detector not manufactured by FANUC, contact the machine tool builder or detector manufacturer for detailed information on the detector.

1.2.4.1 Alarms for built-in detectors (α_i and β_i Pulsecoders) and troubleshooting actions

These alarms concern built-in detectors that are connected directly to the control unit (CNC/servo amplifier).

Based on the alarm number and description, take an appropriate action as described in the following subsection, "Detailed troubleshooting methods".

Alarm No.: Alarm	Description	Possible cause	Action	Detailed troubleshooting method
361: ABNORMAL PHASE DATA(INT)	- Communication error in the Pulsecoder - ID data error	- Pulse coder failure - Noise	Replace the Pulsecoder.	(3) (4)
364: SOFT PHASE ALARM(INT)	Position data alarm	- Noise - Entry of cutting fluid	Check the effect of noise. Replace the Pulsecoder.	(1) (3)
365: BROKEN LED(INT)	LED disconnection	- Pulse coder failure	Replace the Pulsecoder.	(3)
366: PULSE MISS(INT)	Small internal signal amplitude	- Pulse coder failure - Noise	Replace the Pulsecoder.	(3) (4)
367: COUNT MISS(INT)	Position data count error	- Pulse coder failure - Noise	Replace the Pulsecoder.	(3) (4)
368: SERIAL DATA ERROR(INT)	Communication interruption	- Cable disconnection - Pulse coder failure - Noise	Check the cable. Replace the Pulsecoder.	(2) (3) (4)
369: DATA TRANS. ERROR(INT)	Communication data alarm	- Noise	Check the effect of noise.	(1)
453: SPC SOFT DISCONNECT ALARM	Position - pole data error	- Pulse coder failure - Entry of cutting fluid	Replace the Pulsecoder.	(3)

1.2.4.2 Alarms for separate detectors and troubleshooting actions

These alarms concern separate detectors that are connected to the control unit via a separate detector interface unit (SDU).

Based on the alarm number and description, take an appropriate action as described in the following subsection, "Detailed troubleshooting methods".

Alarm No.: Alarm	Description	Possible cause	Action	Detailed troubleshooting method
380: BROKEN LED(EXT)	LED disconnection	- Detector failure	Replace the detector.	(4)
382: COUNT MISS(EXT)	Position data count error			
383: PULSE MISS(EXT)	Small internal signal amplitude			
384: SOFT PHASE ALARM(EXT)	Position data alarm			

Alarm No.: Alarm	Description	Possible cause	Action	Detailed troubleshooting method
385: SERIAL DATA ERROR(EXT)	Communication interruption	- Cable disconnection - Noise - Detector failure	Check the cable. Check the effect of noise. Replace the detector.	(2) (1) (4)
386: DATA TRANS. ERROR(EXT)	Communication data alarm	- Noise	Check the effect of noise.	(1)
381: ABNORMAL PHASE (EXT) 387: ABNORMAL ENCODER(EXT)	For details, contact the machine tool builder or detector manufacturer.			

1.2.4.3 Detailed troubleshooting methods

(1) Checking the effect of noise

Check CNC diagnosis information No.356 (Built-in detector), No.357 (Separate detector).

Normally, 0 is displayed. However, if the position data from the Pulsecoder becomes unstable due to noise or some other factor, this value is incremented. The value is cleared when the CNC unit is powered off. Immediately after the power is turned on, 0 is displayed.

(2) Checking the cable

Check whether the feedback cable is not disconnected and whether the connector is properly plugged.

(3) Replacing the Pulsecoder

(3)-1 Pulse coder replacement procedure

<1> Remove the four M4 hexagon socket head cap screws fastening the Pulsecoder. The M3 bolts fastening the Pulsecoder cover do not need to be loosened. (See the figure at right.)

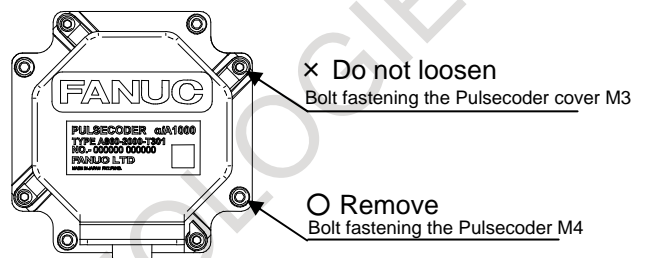

<2> Remove the Pulsecoder and Oldham's coupling (see the following figure).

<3> Set the new Pulsecoder and Oldham's coupling on the motor. Adjust the direction of the mate Oldham's coupling to that of the Oldham's coupling so that the teeth are engaged.

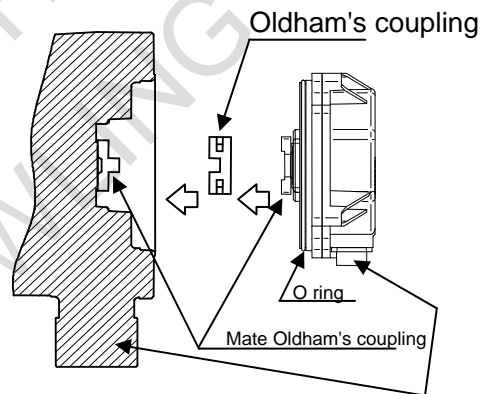

Adjust the connector direction

Push in the Pulsecoder until the O ring fits in the joint between the motor and Pulsecoder. Take care so that the O ring of the Pulsecoder is not bitten.

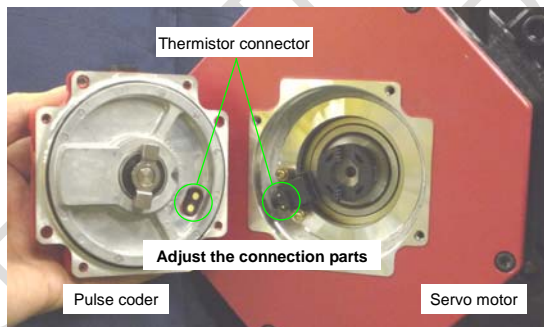

Attach the Pulsecoder in such a direction that the power connector of the servo motor and the feedback cable of the Pulsecoder face the same direction or that the thermistor connection parts of the servo motor and Pulsecoder match each other (see the figure at left).

<4> Fastening the Pulsecoder with the four M4 hexagon socket head cap screws. (Appropriate torque: 1.5 Nm)

(3)-2 Feedback cable plugging procedure

Plug in the feedback cable connector, as instructed in the procedure below, and check that the connector is securely connected.

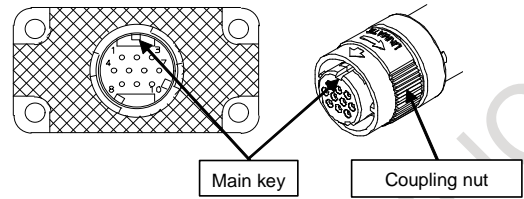

<1> Check the plugging side and key direction.
Check that the plugging side is free of foreign matter, such as dirt or oil.

<2> Plug in the feedback cable connector.
Hold the connector, as shown in the figure at right. Plug in the connector until you hear a click.

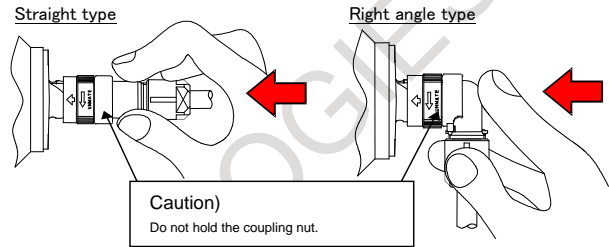

<3> Check the connection condition.
1. Check that the arrow mark of the connector is at the center, as shown in the figure at right. If the arrow mark is not at the center, turn the coupling nut manually until the mark comes to the appropriate position.

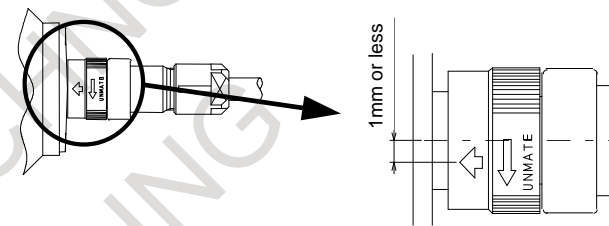

2. Hold the connector by the same part as in <2>, and pull it lightly to check that the connector does not come off. Do not pull the cable.

(4) If troubleshooting is difficult for the user

If the problem is difficult for the user to troubleshoot because it is due to a detector failure or noise, consult with the machine tool builder or FANUC.

1.2.4.4 Maintenance of βiS servo motor (□40 and □60) Pulsecoders

Problems concerning the Pulsecoders of the motors listed in the table below require the maintenance (replacement) of the entire motor (it is not possible to maintain the Pulsecoder alone).

Motor model	Motor specification	Remarks
βiS 0.2/5000	A06B-0111-Bcc3#dddd	Frame size □40
βiS 0.3/5000	A06B-0112-Bcc3#dddd	
βiS 0.4/5000	A06B-0114-Bcc3#dddd	Frame size □60
βiS 0.5/6000	A06B-0115-Bcc3#dddd	
βiS 1/6000	A06B-0116-Bcc3#dddd	

(cc, dddd : Any)

1.3 PREVENTIVE MAINTENANCE OF SERVO AMPLIFIERS

1.3.1 Warnings, Cautions, and Notes on Operation of Servo Amplifiers

This subsection contains the safety precautions on preventive maintenance of a servo amplifier (a generic term to refer to the βiSV and $\beta iSVSP$). These precautions are classified into "warnings", "cautions", and "notes" according to their bearing on safety. Make sure that you understand and comply with these precautions when carrying out the maintenance work.

WARNING

- **Make sure that you are safely dressed and have a safe working environment when performing preventive maintenance for a servo amplifier.**
 - Be dressed safely, e.g. by wearing gloves and safety shoes, to protect against injury due to an edge or protrusion and electric shock.
 - Have the work done by more than one person, where possible, so that immediate action can be taken if an accident occurs when handling a motor.
 - A servo amplifier and AC reactor contain heavy components. Be careful when transporting them or mounting them on the power magnetic cabinet. Also be careful not to get your fingers caught between the power magnetics cabinet and servo amplifier.
- **Before turning on the power, check that the door of the power magnetics cabinet and all other doors.**
 - Ensure that the door of the power magnetics cabinet containing the servo amplifier, as well as all other doors, are closed and locked except during maintenance work.
- **When the need arises to open the door of the power magnetics cabinet, only a person trained in the maintenance of the corresponding machine or equipment should do the task after shutting off the power supply to the power magnetics cabinet by opening both the input circuit breaker of the power magnetics cabinet and the factory switch used to supply power to the cabinet.**
- **Be careful about electric shock, fire, and other accidents.**
 - If the machine must be operated with the door open for adjustment or some other purpose, the operator must keep his or her hands and tools well away from any dangerous voltages. Such work must be done only by a person trained in the maintenance of the machine or equipment.
 - Ensure that the door of the power magnetics cabinet is locked so that the door cannot be opened by anyone, except service personnel or a qualified person trained in maintenance to prevent electric shock, when the servo amplifier is powered on.
 - When the need arises for an operator to open the door of the power magnetics cabinet and perform an operation, ensure that the operator is sufficiently educated in safety or that a protective cover is added to prevent the operator from touching any dangerous part.
 - The servo amplifier contains a large-capacity electrolytic capacitor in it and remains charged for a while after the power is shut off. Before touching the servo amplifier for maintenance or some other purpose, measure the residual voltage of the DC link connection using a tester and check that the red LED for indicating charging is in progress is not lit, in order to ensure safety.
 - After wiring, be sure to close the servo amplifier cover.
 - A loose screw or poor connector contact can cause a motor malfunction or overheating, connection to ground, or short-circuit. Be extremely careful with power supply lines, motor power lines, and DC link connections through which a large electric current flows, because a loose screw or poor connector contact may lead to a fire. Tighten screws and connectors using the specified screw tightening torque.

- The surfaces of the regenerative discharge unit and heat radiator may become very hot. Do not touch them directly by hand.
- **When operating the machine for the first time after preventive maintenance, check that the machine operates as instructed.**
 - To check whether the machine operates as instructed, first specify a small value for the motor and then increase the value gradually. If the motor operates abnormally, perform an emergency stop immediately.
 - When pressing the emergency stop button, check that the motor stops immediately and that the power being supplied to the amplifier is shut off by the magnetic contactor.
- **Notes on alarms**
 - If the machine stops due to an alarm, check the alarm number. Depending on the alarm issued, if the power is supplied without replacing the failed component, another component may be damaged, making it difficult to identify the original cause of the alarm.
 - Before resetting an alarm, ensure that the original cause of the alarm has been removed.
- **If the motor causes any abnormal noise or vibration while operating, stop it immediately.**
 - Using the motor in spite of the abnormal noise or vibration may damage the servo amplifier.
- **Do not disassemble or modify a servo amplifier.**

Do not disassemble or modify a servo amplifier in any way not specified by FANUC; doing so can lead to a failure.

 **CAUTION**

- **Notes on servo amplifier replacement and wiring**
 - The work of servo amplifier replacement and wiring should be carried out by a person trained in the maintenance of the machine and equipment concerned.
 - When replacing a servo amplifier, check that the combination of the amplifier and the motor is appropriate.
 - Check that the servo amplifier is securely mounted on the power magnetics cabinet. If there is any clearance between the power magnetics cabinet and the surface on which the amplifier is mounted, dust entering the gap may hinder the normal operation of the servo amplifier.
 - Ensure that the power supply lines, motor power lines, and signal lines are each connected to the correct terminal or connector.
 - Unless otherwise instructed, do not unplug a connector and plug it back with the power on; doing so may cause the servo amplifier to fail.
 - When mounting or unmounting the servo amplifier, exercise care not to get your fingers caught between the servo amplifier and power magnetics cabinet.
 - Take care not to lose track of removed screws. Turning on the power with any lost screw left in the unit may damage the machine.
 - Exercise care to prevent the power supply lines and motor power lines from being connected to the ground or being short-circuited.
 - Protect the lines from any stress such as bending. Handle the line ends appropriately.
- **Be careful about the handling of a servo amplifier.**
 - Do not disassemble a servo amplifier. Doing so poses the risk of electric shock, because the capacitor may remain charged.
 - Do not apply shock to a servo amplifier. Doing so may damage its components, potentially causing the amplifier to malfunction.

- Do not apply an excessively large force to plastic parts. If a plastic section breaks, it may damage internal parts, thus hindering normal operation or leading to a risk of injury due to a broken section.
- **Be careful about the operating environment of a servo amplifier.**
 - Prevent conductive, combustible, or corrosive foreign matter, mist, or drops of water from entering the inside of the unit. The entry of any such material may cause the unit to explode, break, malfunction, etc.
 - Exercise care to prevent cutting fluid, oil mist, cutting chips, or other foreign matter from attaching to the radiator or fan motor exposed to the outside of the power magnetics cabinet. Otherwise, the servo amplifier may become unable to meet its specifications. The service lives of the fan motor and semiconductors can also be reduced.
- **Clean the heat sink and fan motor on a regular basis.**
 - Replace the filter of the power magnetics cabinet on a regular basis.
 - Before cleaning the heat sink, shut down the power and ensure that the temperature of the heat sink is as cool as the room temperature. The heat sink is very hot immediately after power shutdown, touching it may cause burn injury.
 - When cleaning the heat sink by blowing air, be careful about dust scattering. Conductive dust attached to the servo amplifier or its peripheral equipment can lead to a failure.

NOTE

- **Make sure that there is sufficient maintenance clearance around the doors of the machine and equipment.**
- **Do not step or sit on the servo amplifier, or do not apply shock to it.**
- **Do not remove a nameplate from a motor.**
 - The nameplate is necessary to identify the servo amplifier during maintenance work.
 - If a nameplate comes off, be careful not to lose it.

NOTE

- 1 This manual is focused on the preventive maintenance work to be performed for a FANUC servo amplifier. The information contained herein may not apply depending on the type or configuration of the machine. When reading this manual, refer to the manual of the machine as well. If you have any questions or doubts, do not act on your own; please contact the machine tool builder or FANUC.
- 2 For detailed information about a servo amplifier, see the manual list shown earlier and, if necessary, obtain the latest version of the corresponding manual.

1.3.2 Preventive Maintenance of a Servo Amplifier

To use a servo amplifier safely throughout its entire service life, perform daily and periodic inspections.

⚠ CAUTION

- 1 The preventive maintenance method differs from machine to machine in many respects. Depending on the machine in use, it may be difficult for the user to perform periodic inspection or cleaning. If you are not sure about anything as to preventive maintenance, consult with the machine tool builder and ensure that you can perform periodic inspection and cleaning.
- 2 The machine should be used within the scope of specification defined by the machine tool builder. Using the machine in any way that is outside the specified scope can reduce the servo amplifier's service life or cause a failure.

Inspection part	Inspection item	Inspection interval		Judgment criterion
		Routine	Periodic	
Operating environment	Ambient temperature	√		Around the power magnetics cabinet: 0°C - 45°C Inside the power magnetics cabinet: 0°C - 55°C
	Humidity	√		90% or below RH (dew condensation not allowed)
	Dust/oil mist	√		There shall be no dust or oil mist attached near the servo amplifier.
	Cooling air path	√		The cooling fan shall be operating normally without the air flow being interrupted.
	Abnormal vibration/noise	√		- No abnormal noise or vibration shall be present that has not been experienced in the past. - Vibration near the servo amplifier shall be 0.5 G or less.
	Supply voltage	√		200-V input type: Within 200 - 240 V 400-V input type: Within 400 - 480 V
Servo amplifier	General	√		There shall be no abnormal noise or smell, and there shall be no dust or oil mist attached.
	Screw		√	There shall be no loose screw.
	Fan motor ^(NOTE 1, 2)	√		- There shall be no abnormal vibration or noise, and the fan blades shall be rotating normally. - There shall be no dust or oil mist attached.
	Connector		√	There shall be no loose or broken connector.
	Cable		√	There shall be no sign of overheating or sheath deterioration (discoloration or crack).
CNC	Absolute ^(NOTE 2) Pulse coder battery	√		The machine operator's panel or screen shall not display the alarm indicating the battery voltage of the absolute Pulsecoder is low.
External equipment	Magnetic contactor		√	The contactor shall not rattle or chatter.
	Ground fault interrupter		√	The interrupter shall be able to trip.
	AC reactor		√	There shall be no hum.

NOTE

- 1 Fan motors are periodic-replacement parts. It is recommended to inspect fan motors on a routine basis and replace them in a preventive manner.
- 2 Fan motors and batteries are periodic-replacement parts. It is recommended to keep spare parts.

1.3.3 Maintenance of a Servo Amplifier

1.3.3.1 Display of the servo amplifier operation status

The STATUS LEDs on the front of the servo amplifier indicate the operation status of the servo amplifier (whether it is operating normally, the type of alarm, etc.). Use these LEDs for maintenance, inspection, troubleshooting, etc.

⚠ CAUTION

A servo amplifier failure may arise from a combination of multiple causes, in which case it can be difficult to identify all those causes. Handling the failure in an improper way may worsen the problem. It is therefore important to analyze the failure status minutely and identify the true cause or causes of the failure. There may be cases in which the failure appears to have been fixed but later recurs or cause a more serious trouble. If you are not sure about the root cause of or corrective action for a failure, do not act on your own; please contact the machine tool builder or FANUC for instructions on proper action.

- (1) βiSV : See Chapter 4, “CONFIRMATION OF THE OPERATION” in Part I, “START-UP PROCEDURE FOR βiSV .”
- (2) $\beta iSVSP$: See Chapter 4, “CONFIRMATION OF THE OPERATION” in Part III, “S START-UP PROCEDURE FOR $\beta iSVSP$.”

1.3.3.2 Replacement of a fan motor

- (1) βiSV : See Section 4.1, “REPLACEMENT OF A FAN MOTOR” in Part II, “TROUBLESHOOTING FOR βiSV .”
- (2) $\beta iSVSP$: See Section 4.1, “REPLACEMENT OF A FAN MOTOR” in Part IV, “TROUBLESHOOTING FOR $\beta iSVSP$.”

1.4 REPLACING BATTERY FOR ABSOLUTE PULSECODERS

- (1) βiSV : See Section 4.2, “REPLACING BATTERY FOR ABSOLUTE PULSECODERS” in Part II, “TROUBLESHOOTING FOR βiSV .”
- (2) $\beta iSVSP$: See Section 4.2, “REPLACING BATTERY FOR ABSOLUTE PULSECODERS” in Part IV, “TROUBLESHOOTING FOR $\beta iSVSP$.”

VI. MOTOR MAINTENANCE

JR AUTOMATION TECHNOLOGIES INC*
JDOWLING

JR AUTOMATION TECHNOLOGIES INC*
JDOWLING

1 SERVO MOTOR MAINTENANCE

1.1 SERVO MOTOR MAINTENANCE PARTS

1.1.1 Pulsecoder

The following lists the ordering specification numbers for maintenance.

(1) Pulsecoder: ordering specification

Motor model	Motor specification		Pulsecoder: ordering specification		
β iS series	A06B-0aaa-BccX (aaa, cc : Any)	X=3	A860-2020-T301	β iA128	Standard specification
β iF series	A06B-0aaa -BccX #0100 (aaa, cc : Any)	X=3	A860-2020-T321	β iA128	IP67 specification
β iSc series	A06B-0aaa-BccX (aaa, cc : Any)	X=7	A860-2020-T361	β iA128 (dedicated to the β iSc)	Standard specification
	A06B-0aaa -BccX #0100 (aaa, cc : Any)	X=7	A860-2020-T371	β iA128 (dedicated to the β iSc)	IP67 specification

(2) Oldham's coupling: ordering specification

Motor model	Motor specification	Oldham's coupling: ordering specification
β iS series β iSc series β iF series	A06B-0aaa-BccX (aaa, cc, X : Any)	A290-0501-V535

NOTE

Problems concerning the Pulsecoders of the motors listed in the table below require the maintenance (replacement) of the entire motor.
(It is not possible to maintain the Pulsecoder alone.)

Motor model	Motor specification	Remark
β iS 0.2/5000	A06B-0111-Bcc3#dddd	Frame size □40
β iS 0.3/5000	A06B-0112-Bcc3#dddd	
β iS 0.4/5000	A06B-0114-Bcc3#dddd	Frame size □60
β iS 0.5/6000	A06B-0115-Bcc3#dddd	
β iS 1/6000	A06B-0116-Bcc3#dddd	

(cc, dddd : Any)

2 SPINDLE MOTOR MAINTENANCE PARTS

2.1 SPINDLE MOTOR MAINTENANCE PARTS

(1) Parts of the terminal box (βiI , βiI_P , and βiIc series)

Model	Terminal box assembly	Lid of terminal box
$\beta i I 3/10000$, $\beta i I 6/10000$ $\beta i Ic 3/6000$, $\beta i Ic 6/6000$	A290-1404-T400	A290-1402-V410
$\beta i I 8/8000$ to $\beta i I 15/7000$ $\beta i I_P 8/6000$ to $\beta i I_P 30/6000$ $\beta i Ic 8/6000$	A290-1406-T400	A290-1406-V410
$\beta i I_P 40/6000$	A290-1410-T401	A290-1410-V410

(2) Fan motor parts (βiI , βiI_P , and βiIc series)

Model	Fan assembly (*1)	Fan cover	Fan motor	Exhaust direction
$\beta i I 3/10000$, $\beta i I 6/10000$ $\beta i Ic 3/6000$, $\beta i Ic 6/6000$	A290-1404-T500	A290-1404-X501	A90L-0001-0538/R	Rear
	A290-1404-T501		A90L-0001-0538/F	Front
$\beta i I 8/8000$ to $\beta i I 12/8000$ $\beta i I_P 8/6000$, $\beta i I_P 12/6000$ $\beta i Ic 8/6000$	A290-1406-T500	A290-1406-X501	A90L-0001-0515/R	Rear
	A290-1406-T501		A90L-0001-0515/F	Front
$\beta i I 15/7000$ $\beta i I_P 15/6000$ to $\beta i I_P 30/6000$	A290-1408-T500	A290-1408-X501	A90L-0001-0548/R	Rear
	A290-1408-T501		A90L-0001-0548/F	Front
$\beta i I_P 40/6000$	A290-1412-T510	A290-1412-X502	A90L-0001-0554/RW	Rear
	A290-1412-T511		A90L-0001-0554/FW	Front

NOTE

1 These drawing numbers include fan motors.

APPENDIX

JR AUTOMATION TECHNOLOGIES INC*
JDOWLING

JR AUTOMATION TECHNOLOGIES INC*
JDOWLING

A MEASURING SERVO MOTOR WAVEFORMS (TCMD, VCMD)

To use a servo motor in a good performance condition for a long time and prevent any failure from occurring, the TCMD and VCMD waveforms of the servo motor can be checked as diagnosis.

(1) Observation of torque command (TCMD) and speed command (VCMD) waveforms

Check whether there is no abnormality in the waveforms.

For how to measure the TCMD and VCMD waveforms, refer to the FANUC AC SERVO MOTOR αi series/FANUC AC SERVO MOTOR βi series/FANUC LINEAR MOTOR LiS series/FANUC SYNCHRONOUS BUILT-IN SERVO MOTOR DiS series Parameter Manual (B-65270EN).

The waveforms vary according to the operating conditions such as load and cutting speed. Note that you should make comparisons under the same condition (for example, during fast traverse to the reference position or low-speed cutting).

(2) Diagnosis by waveforms

Check the measured waveforms to see whether:

<1> The peak current is within the limit to the current in the amplifier during rapid traverse, acceleration, or deceleration.(TCMD)

The limit to the amplifier current is listed below.

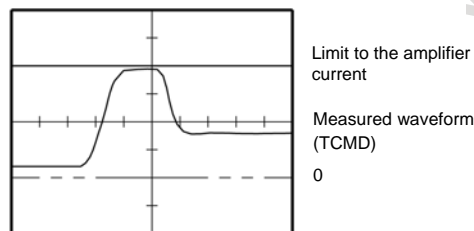

⇒ The motor used to accelerate/decelerate with the amplifier current within the limit (the acceleration/deceleration torque used to be sufficient), but something is wrong now. If this is the case, the probable causes are:

- The load conditions in the machine have changed because of changed friction or reduced machine efficiency after long period of use.
- Motor failure

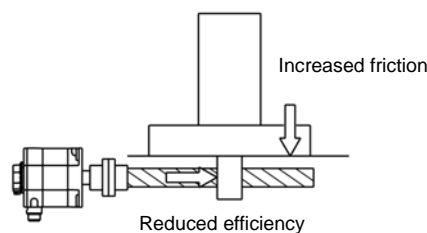

[Table 1]

Models		Current value
200V	400V	
$\beta iS0.2/5000$, $\beta iS0.3/5000$		4Ap
	$\beta iS2/4000HV$, $\beta iS4/4000HV$, $\beta iS8/3000HV$	10Ap
$\beta iS0.4/5000$, $\beta iS0.5/6000$, $\beta iS1/6000$ $\beta iS2/4000$, $\beta iS4/4000$, $\beta iS8/3000$, $\beta iS12/2000$ $\beta iSc2/4000$, $\beta iSc4/4000$, $\beta iSc8/3000$, $\beta iSc12/2000$ $\beta iF4/3000$, $\beta iF8/2000$, $\beta iF12/2000$	$\beta iS12/3000HV$, $\beta iS22/2000HV$	20Ap
$\beta iS12/3000$, $\beta iS22/2000$ $\beta iSc12/3000$, $\beta iSc22/2000$ $\beta iF22/2000$	$\beta iS22/3000HV$, $\beta iS30/2000HV$, $\beta iS40/2000HV$	40Ap
$\beta iS22/3000$, $\beta iS30/2000$, $\beta iS40/2000$ $\beta iF30/1500$		80Ap

<2> The waveform has ripple during constant-speed feeding (VCMD).

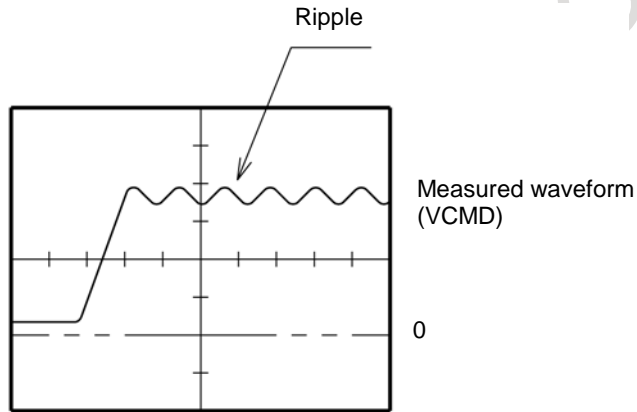

<3> The current waveform has ripple or jumps when the motor is not rotating (VCMD).

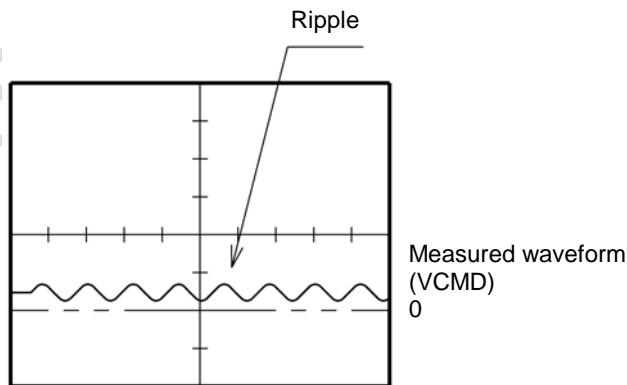

If you find anything unusual in relation to the above items <1> to <3>, contact your FANUC service staff.

B USING THE SPINDLE CHECK BOARD

B.1 OBSERVING DATA USING THE SPINDLE CHECK BOARD

B.1.1 Overview

By using the spindle check board, you can convert digital values used for spindle control in the β iSVSP to analog voltage, and observe the conversion result with an oscilloscope. For internal data observation, you can use a two-channel analog output (CH1 and CH2, output: -5 to +5 V) and an output for checking specific bits such as bit data (CH1D and CH2D). You can also view internal data on a 5-digit indicator.

B.1.2 Main Characteristics

Item		
Measurement points	CH1,CH2	CH1D,CH2D
Output voltage range	-5V to +5V	H:2Vmin L:0.8Vmax
Resolution	About 39 mV (10V/256)	-
Input impedance for external measuring equipment	10k Ω min	10k Ω min

B.1.3 Observation Method

By setting data using four setting switches on the spindle check board, you can output internal data to the 5-digit indicator, analog voltage output circuit, and channels 1 and 2 (LM and SM or CH1 and CH2).

Data on channels 1 and 2 is output from an 8-bit D/A converter.

Channels 1 and 2 correspond to the check terminals as listed below.

Measurement point	Check terminal
Channel 1	CH1 CH1D, data bit 0
Channel 2	CH2 CH2D, data bit 0

B.1.4 Setting Data to Be Observed

- <1> Press the four setting switches at the same time for at least 1 second. [FFFFF] will be displayed on the indicator.
- <2> Turn the switches off and press the [MODE] switch. [d-00] will be displayed on the indicator and the system will enter the internal data observation mode.
- <3> Even in this mode, the motor can be operated normally. Press the [UP] or [DOWN] switch while holding down the [MODE] switch. The indicator display will change in the range of [d-00] to [d-12].
- <4> Addresses d-01 to d-12 correspond to the destinations of the internal data of the spindle as follows:
 - d-01 to 04: Specifies the number, data shift amount, and output display format (decimal or hexadecimal) of data to be output to the indicator.
 - d-05 to 08: Specifies the number and data shift amount of data to be output to channel 1, and whether an offset is provided.
 - d-09 to d-12: Specifies the number and data shift amount of data to be output to channel 2, and whether an offset is provided.

- <5> Select address [d-xx] as instructed in step <3> for setting data.
- <6> Turn the [MODE] switch off. [d-xx] will disappear 0.5 seconds later, and data will be displayed for 1 second. Change the data setting using the [UP] or [DOWN] switch within the second.
- <7> If more than 1 second elapses without pressing the switch, the data setting cannot be changed. In this case, turn the [MODE] switch on and off, and you can perform operation from the beginning of step <6>.

B.1.5 Descriptions and Initial Values of Addresses

[Output to the indicator]

Address	Description	Initial value
d-01	Sets a data number.	0
d-02	Shift amount at data output (0 to 31 bits)	0
d-03	Data shift direction 0: Shifts data right. 1: Shifts data left.	0
d-04	Display format 0: Decimal notation 1: Hexadecimal notation (0 to F)	0

[Output to channel 1]

Address	Description	Initial value
d-05	Sets a data number.	218 (Phase U current)
d-06	Shift amount at data output (0 to 31 bits)	8
d-07	Data shift direction 0: Shifts data right. 1: Shifts data left.	0
d-08	Offset 0: Not provided. 1: Provided.	1

[Output to channel 2]

Address	Description	Initial value
d-09	Sets a data number.	19 (Motor speed)
d-10	Shift amount at data output (0 to 31 bits)	18
d-11	Data shift direction 0: Shifts data right. 1: Shifts data left.	0
d-12	Offset 0: Not provided. 1: Provided.	1

B.1.6 Principles in Outputting the Internal Data of the Spindle

The data length is 32 bits (BIT31 to BIT00) unless it is described as 16 bits.

BIT31	BIT03	BIT02	BIT01	BIT00
-------	-------	-------	-------	-------	-------

(1) Examples of outputting data to the indicator

Example 1: Displaying data in decimal

When the data shift amount (d-02) is 0 and data is displayed in decimal (d-04 = 0), the last 16 bits of data (BIT15 to BIT00) are converted to decimal (0 to 65535 max.) and displayed.

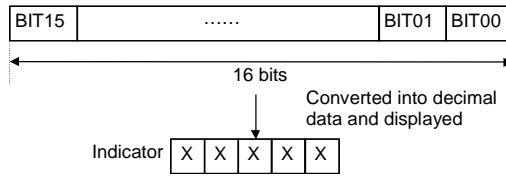

Example 2: Displaying data in hexadecimal

When the data shift amount (d-02) is 0 and data is displayed in hexadecimal (d-04 = 1), the last 16 bits of data (BIT15 to BIT00) are converted to hexadecimal (0 to FFFF max.) and displayed.

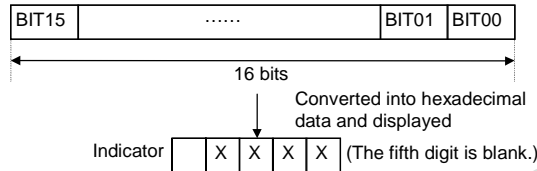

Example 3: Shifting data left

When the data shift amount (d-02) is 3, the shift direction is left (d-03 = 1), and data is displayed in hexadecimal (d-04 = 1), BIT12 to BIT00 and (the last three bits assumed to be 0) of data are converted to hexadecimal (0 to FFFF max.) and displayed.

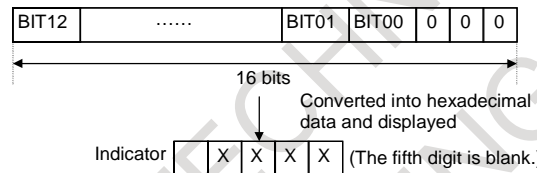

Example 4: Shifting data right

When the data shift amount (d-02) is 5, the shift direction is right (d-03 = 0), and data is displayed in decimal (d-04 = 0), BIT20 to BIT05 of data are converted to decimal (0 to 65535 max.) and displayed.

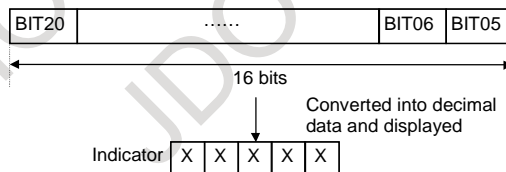

Example 5: Shifting data right when the data length is 16 bits

When the data length is 16 bits, the data shift amount (d-02) is 5, the shift direction is right (d-03 = 0), and data is displayed in decimal (d-04 = 0), (the first five bits assumed to be 0) and BIT15 to BIT05 of data are converted to decimal and displayed.

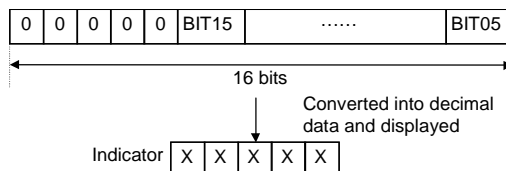

(2) Examples of outputting data to channel 1

Internal data is output to channel 1 by setting it in an 8-bit D/A converter.

The D/A converter output ranges from -5 to +5 V, depending on a set value of internal data. See the table below.

Internal data in binary (decimal)	d-08 setting (whether to provide an offset)	Output to channel 1
00000000(0)	0	-5V
11111111(255)	0	+4.96V
10000000(-128)	1	-5V
00000000(0)	1	0V
01111111(127)	1	+4.96V

Example 1: Setting data

When the data shift amount (d-06) is 0 and no offset is provided (d-08 = 0), the last eight bits of data (BIT07 to BIT00) are set in the D/A converter.

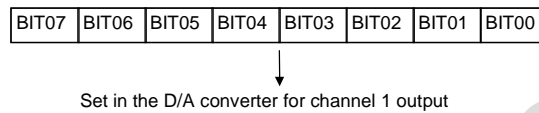

Example 2: Shifting data left

When the data shift amount (d-06) is 3, the shift direction is left (d-07 = 1), and no offset is provided (d-08 = 0), BIT14 to BIT00 and (the last three bits assumed to be 0) of data are set in the D/A converter.

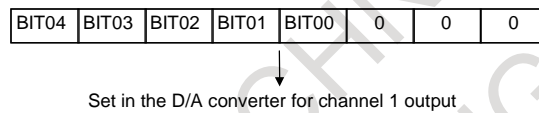

Example 3: Shifting data right

When the data shift amount (d-06) is 10, the shift direction is right (d-07 = 0), and no offset is provided (d-08 = 0), BIT17 to BIT10 of data are set in the D/A converter.

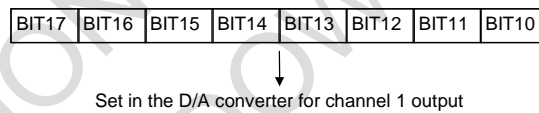

Example 4: Shifting data right when the data length is 16 bits

When the data length is 16 bits, the data shift amount (d-06) is 10, the shift direction is right (d-07 = 0), and no offset is provided (d-08 = 0), (the first two bits assumed to be 0) and BIT15 to BIT10 of data are set in the D/A converter.

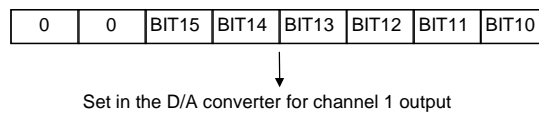

Example 5: When an offset is provided

When the data shift amount (d-06) is 10, the shift direction is right (d-07 = 0), and an offset is provided (d-08 = 1), BIT17 to BIT10 of data with 1 added to the most significant bit (BIT17) are set in the D/A converter.

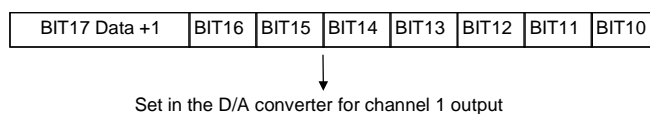

Example 6: Observing bit data

When the data shift amount (d-06) is 0 and no offset is provided (d-08 = 0), the status of the least significant bit (BIT00) can be observed as a high/low level at check terminal CH1D.

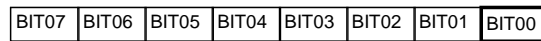

↓
Output to check terminal CH1D

(3) Examples of outputting data to channel 2

Data is output to channel 2 in the same way as to channel 1. The addresses for setting data (d-09 to d-12) are different from those for outputting data to channel 1.

You can set motor speed information in channel 1 and the number of errors in channel 2 to observe the change in each data item using the two channels.

B.1.7 Data Numbers

(1) Data numbers

Data No.	Description	Data length	Remarks
Main data			
16	Motor speed command	32	Bit 12 (BIT12) indicates the unit of min^{-1} .
19	Motor speed	32	Bit 12 (BIT12) indicates the unit of min^{-1} . (Estimated value for the β iSVSP spindle sensorless model)
25	Motor speed deviation	32	(Speed command - motor speed) Bit 12 (BIT12) indicates the unit of min^{-1} .
4	Move command	32	Number of command pulses for ITP (usually 8 msec)
9	Position error	32	Number of erroneous pulses (Spindle synchronous control, Cs contour control, and rigid tapping)
90	Torque command	16	0 to ± 16384
131	Speedometer data	16	SM terminal
132	Load meter data	16	LM terminal
136	Position error	32	Number of erroneous pulses (position coder-based orientation)
Data between the spindle and CNC			
5	Speed command data	16	± 16384 for the maximum speed command
6	Spindle control signal 1	16	See the command signal from the PMC to the spindle in (3).
10	Load meter data	16	+32767 for the maximum output
11	Motor speed data	16	± 16384 for the maximum speed
12	Spindle status signal 1	16	See the status signal from the spindle to the PMC in (3).
66	Spindle control signal 2	16	See the command signal from the PMC to the spindle in (3).
182	Spindle status signal 2	16	See the status signal from the spindle to the PMC in (3).
Other data			
218	Phase U current (A/D conversion data)	16	10 V/FS by shifting 8 bits left
219	Phase V current (A/D conversion data)	16	
162	DC link voltage	16	1000 V/FS by shifting 8 bits left

(2) Internal data conversion

Data No.	Signal name	Description (when the shift amount is set to 8)	
218	IU	Phase U current	The current is positive when it is input to the amplifier.
219	IV	Phase V current	*1
162	VDC	DC link voltage signal 100V/1V	

*1 Current conversion result for channels 218 and 219

Model	Conversion result
β iSVSP*-5.5	16.7A/1V

Model	Conversion result
β iSVSP*-7.5	26.7A/1V
β iSVSP*-11	33.3A/1V
β iSVSP*-15	50.0A/1V
β iSVSP*-18	66.7A/1V

- (3) Spindle control signals and spindle status signals
 Shown below are the data numbers for the PMC signals used by the spindle and the configuration of each data item. For details of each signal, refer to Chapter 3, "PMC SIGNALS (CNC ↔ PMC)" in "FANUC AC SPINDLE MOTOR α i series/FANUC AC SPINDLE MOTOR β i series/FANUC BUILT-IN SPINDLE MOTOR Bi series Parameter Manual (B-65280EN)".

NOTE
 The β iSVSP does not always support all of the following bits.

- (a) Data number 6: Spindle control signal 1

#15	#14	#13	#12	#11	#10	#9	#8
RCH	RSL	INTG	SOCN	MCFN	SPSL	*ESP	ARST
#7	#6	#5	#4	#3	#2	#1	#0
MRDY	ORCM	SFR	SRV	CTH1	CTH2	TLMH	TLML

- (b) Data number 66: Spindle control signal 2

#15	#14	#13	#12	#11	#10	#9	#8
			DSCN	SORSL	MPOF		
#7	#6	#5	#4	#3	#2	#1	#0
RCHHG	MFNHG	INCMD	OVR		NRRO	ROTA	INDX

- (c) Data number 12: Spindle status signal 1

#15	#14	#13	#12	#11	#10	#9	#8
				RCFN	RCHP	CFIN	CHP
#7	#6	#5	#4	#3	#2	#1	#0
ORAR	TLM	LDT2	LDT1	SAR	SDT	SST	ALM

- (d) Data number 182: Spindle status signal 2

#15	#14	#13	#12	#11	#10	#9	#8
#7	#6	#5	#4	#3	#2	#1	#0
			EXOF	SOREN		INCST	PC1DT

B.1.8 Examples of Observing Data

- (1) Example of observing a position error using channel 1

Address	Description	Sample data setting			
d-05	Data number	9	9	9	9
d-06	Data shift amount	0	0	1	2
d-07	Data shift direction	0	0	1	1
d-08	Offset	1	0	1	1
Data unit (NOTE)		256p/FS	512p/FS	128p/FS	64p/FS

NOTE
 FS=10V(-5V to +5V)

(2) Example of observing the motor speed using channel 2

Address	Description	Sample data setting		
d-09	Data number	19	19	19
d-10	Data shift amount	12	13	11
d-11	Data shift direction	0	0	0
d-12	Offset	0	0	0
Data unit ^(NOTE)		256min ⁻¹ /FS	512min ⁻¹ /FS	128min ⁻¹ /FS

NOTE

FS=10V(-5V to +5V)

(3) Observing of phase U current in the β iSVSP*-11

Setting the observing data

Data number:	218
Data shift amount:	8
Data shift direction:	0
Offset:	1

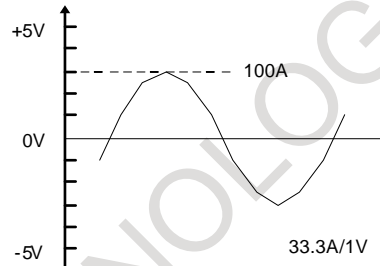

B.2 CHECKING PARAMETERS USING THE SPINDLE CHECK BOARD

B.2.1 Overview

By using the spindle check board, you can check parameter values transferred to the β iSVSP. Specify a parameter number using the four setting switches on the spindle check board, and check the parameter value on the 5-digit indicator.

B.2.1.1 Checking parameters

- <1> Press the four setting switches at the same time for at least 1 second. [FFFFFF] will be displayed on the indicator.
- <2> Turn the switches off and press the [MODE] switch. [d-00] will be displayed on the indicator and the system will enter the internal data observation mode.
- <3> Set "0" for [d-00] and press the [MODE] and [DATA SET] switches at the same time for at least 1 second. [CCCCC] will be displayed on the indicator.
- <4> Turn the switches off and press the [MODE] switch. [F-xxx] will be displayed on the indicator and the system will enter the spindle parameter check mode (F-mode). (Even in this mode, the motor can be operated normally.)
- <5> Press the [UP] or [DOWN] switch while holding down the [MODE] switch (with [F-xxx] displayed). The number of [F-xxx] will increase or decrease. Set the internal number of a parameter you want to check. For correspondences between the parameter internal numbers and NC parameter numbers, refer to the parameter list in the appendix of the Parameter Manual.
- <6> Turn the switches off. The parameter value corresponding to the set internal number will be displayed for about 1 second. (Bit parameter values are displayed in hexadecimal.)

JR AUTOMATION TECHNOLOGIES INC*
JDOWLING

ADDITIONAL INFORMATION

JR AUTOMATION TECHNOLOGIES INC*
JDOWLING

JR AUTOMATION TECHNOLOGIES INC*
JDOWLING

Addition of the inspection item when the motor rotates abnormally

1. Type of applied technical documents

Title	<p>FANUC AC SERVO MOTOR αi series, FANUC AC SPINDLE MOTOR αi series, FANUC SERVO AMPLIFIER αi series MAINTENANCE MANUAL</p> <p>FANUC AC SERVO MOTOR βi series, FANUC AC SPINDLE MOTOR βi series, FANUC SERVO AMPLIFIER βi series MAINTENANCE MANUAL</p> <p>FANUC AC SERVO MOTOR βi-B/βi series, FANUC AC SPINDLE MOTOR βi series, FANUC SERVO AMPLIFIER βi-B series MAINTENANCE MANUAL</p> <p>FANUC AC SERVO MOTOR αi-B/αi series, FANUC AC SPINDLE MOTOR αi -B series, FANUC SERVO AMPLIFIER αi-B series, FANUC AC SERVO MOTOR βi-B/βi series, FANUC AC SPINDLE MOTOR βi-B series, FANUC SERVO AMPLIFIER βi-B series MAINTENANCE MANUAL</p>
Spec. No./Ver.	<p>B-65285EN/04</p> <p>B-65325EN/02</p> <p>B-65425EN/02</p> <p>B-65515EN/01</p>

2. Summary of change

Group	Name/Outline	New·Add Correct·Del	Applicable Date
Basic Function			
Optional Function			
Unit			
Maintenance Parts			
Notice			
Correction	Addition of the inspection item when the motor rotates abnormally	Add	Jul, 2018
Another			

				Title	Addition of the inspection item when the motor rotates abnormally		
				Draw.	B-65285EN/04-04, B-65325EN/02-01, B-65425EN/02-01, B-65515EN/01-01		
01	18.07.09	A. Nishioka	New design	FANUC CORPORATION			
Edit	Date	Design	Description	PAGE	1/2		

3. Outline

Noise and vibration from the motor may be occurred by the phase loss of power line, for example the connection failure, etc.

The confirmation of the cable connection is added to the inspection item when the motor rotates abnormally.

4. Details of correction

Items described in the following table need be checked when the motor rotates abnormally.

Table 1: Main inspection items when the motor rotates abnormally

Operation of the motor	Noise/vibration	<ul style="list-style-type: none"> - Check for any abnormal noise or vibration not only when the motor is running (the spindle is rotating) but also when it is stopped. - Abnormal noise heard when the motor is rotating indicates an abnormality of the bearing or a failure inside the motor. - Check the cable connections. Especially, check whether there is any phase loss of power line. - If abnormal noise is generated from the connection section of a Spindle Amplifier, check the following items: <ul style="list-style-type: none"> + Belt connection: Check whether the belt tension is appropriate. + Gear connection: Check whether an appropriate value is set for the gear backlash. + Coupling connection: Check whether the coupling is free from deformation, crack, and looseness. 	} Add
	Movement	<ul style="list-style-type: none"> - Check that the motor operates normally and smoothly. - If the circuit breaker trips at the same time the motor starts to operate, it indicates abnormal motor windings. 	
	Heat	<p>Check whether the motor does not overheat during the normal operation cycle.</p> <p>Note: While the motor is running or immediately after it is stopped, the motor surface may become very hot. Instead of touching the motor directly by hand, use a thermolabel, surface thermometer, etc.</p>	

				Title	Addition of the inspection item when the motor rotates abnormally		
				Draw.	B-65285EN/04-04, B-65325EN/02-01, B-65425EN/02-01, B-65515EN/01-01		
01	18.07.09	A. Nishioka	New design	FANUC CORPORATION			
Edit	Date	Design	Description				

Cleaning/ Inspection Procedures for Fan Motor of Spindle Motor

1. Type of applied technical documents

Name	FANUC AC SPINDLE MOTOR αi series, DESCRIPTIONS FANUC AC SERVO MOTOR αi series, FANUC AC SPINDLE MOTOR αi series, FANUC SERVO AMPLIFIER αi series MAINTENANCE MANUAL FANUC AC SPINDLE MOTOR βi series, DESCRIPTIONS FANUC AC SERVO MOTOR βi series, FANUC AC SPINDLE MOTOR βi series, FANUC SERVO AMPLIFIER βi series MAINTENANCE MANUAL FANUC AC SPINDLE MOTOR αi -B series, FANUC AC SPINDLE MOTOR βi -B series, DESCRIPTIONS FANUC AC SERVO MOTOR αi -B/ αi series, FANUC AC SPINDLE MOTOR αi -B series, FANUC SERVO AMPLIFIER αi -B series, FANUC AC SERVO MOTOR βi -B/ βi series, FANUC AC SPINDLE MOTOR βi -B series, FANUC SERVO AMPLIFIER βi -B series MAINTENANCE MANUAL
	Spec.No.

2. Summary of Change

Group	Name	New, Add, Correct, Delete,	Applicable Date
Basic Function			
Optional Function			
Unit			
Maintenance Parts			
Notice			
Correction			
Another	Cleaning/ Inspection Procedures for Fan Motor of Spindle Motor	Add	Oct.2019

				TITLE Cleaning/ Inspection Procedures for Fan Motor of Spindle Motor	
				DRAW. No. B-65272EN/08-09 B-65285EN/04-05 B-65312EN/05-03 B-65325EN/02-02 B-65452EN/03-04 B-65515EN/01-03	
				CUST	
01	12.Nov.19	Mukai	Newly designed	Hayahi	
Ed.	Date	Design	Description		FANUC CORPORATION SHEET 1/10

Cleaning/ Inspection Procedures for Fan Motor of Spindle Motor

1. Outline

In order to guarantee enough cooling of spindle motors, regular cleaning and inspection is necessary as described in DESCRIPTIONS and MAINTENANCE MANUAL.

However, there are cases in which cleaning and inspection is not conducted regularly and therefore leading to failure and trouble. If the fan motor stop, an overheat alarm may occur and the machine may stop. In the worst case, driving under conditions in which cutting fluid or its mist is splashed on the motor may lead to combustibility of sludge accumulated on the fan motors(*). Regular cleaning and inspection is highly recommended.

Please contact FANUC if there is any question regarding the contents of this report. FANUC service department will conduct inspection at your request so please contact FANUC if necessary.

(*) Our fan cover is made with self-extinguishing material which the flammability is V-0, so if there is no foreign matter, it is not combustibility.

2. Frequency of Cleaning and Inspection

Recommended: once every three months

The standard frequency of cleaning and inspection is once every three months. The frequency may differ according to the condition the motor is used in.

3. Safety Precautions

When cleaning and inspecting the fan motors, please keep in mind the precautions described as follows.

⚠ WARNING

- Before touching a motor, shut off the power to it.
Even if a motor is not rotating, there may be a voltage across the terminals of the motor. Especially before touching a power supply connection, take sufficient precautions. Otherwise you may get electric shocks.
- A voltage is applied for a while after the power is shut off. Before touching a motor, be sure to check 0 V.
There is a high voltage across power terminals for a while after the power is shut off. Do not touch a motor or connect the motor to another device before checking the voltage. Otherwise you may get electric shocks or the motor may get damaged. Be sure to check that the voltage is lowered to 0 V, then touch the motor.
- Do not insert your finger or a stick into the fan motor.
A cover is mounted on the fan motor, but a stick may get inside it. When the fan is rotating, inserting your finger or a stick may injure you.

Ed.	Date	Design	Description	TITLE Cleaning/ Inspection Procedures for Fan Motor of Spindle Motor	
01	12.Nov.19	Mukai	Newly designed Hayahi	DRAW. No.	CUST
				B-65272EN/08-09 B-65285EN/04-05 B-65312EN/05-03 B-65325EN/02-02 B-65452EN/03-04 B-65515EN/01-03	
				FANUC CORPORATION	SHEET 2/10

⚠ CAUTION

- Do not touch a motor when it is running or immediately after it stops.
A motor may get hot when it is running. Do not touch the motor before it gets cool enough. Otherwise, you may get burned.
- Be careful not get your hair or cloths caught in a fan.
Be careful especially for a fan used to generate an inward air flow.
Be careful also for a fan even when the motor is stopped, because it continues to rotate while the amplifier is turned on.
- Be sure to connect motor cables correctly.
An incorrect connection of a cable cause abnormal heat generation, equipment malfunction, or failure.
Always use a cable with an appropriate current carrying capacity (or thickness). For how to connect cables to motors, refer to their respective specification manuals.

※ Precautions are classified into Warning and Caution according to their bearing on safety. Read all Warnings and Cautions thoroughly before attempting to use the machine.

⚠ WARNING

Applied when there is a danger of the user being injured or when there is a danger of both the user being injured and the equipment being damaged if the approved procedure is not observed.

⚠ CAUTION

Applied when there is a danger of the equipment being damaged, if the approved procedure is not observed.

				TITLE Cleaning/ Inspection Procedures for Fan Motor of Spindle Motor	
				DRAW. No. B-65272EN/08-09 B-65285EN/04-05 B-65312EN/05-03 B-65325EN/02-02 B-65452EN/03-04 B-65515EN/01-03	
				CUST	
01	12.Nov.19	Mukai	Newly designed	Hayahi	
Ed.	Date	Design	Description		FANUC CORPORATION SHEET 3/10

4. Cleaning/ Inspection Procedures and Work Descriptions

4.1 Cleaning/ Inspection Procedures

Regular inspection is composed of checking mechanical (i.e. rotation) and electrical state of the fan motor.

Follow the procedures below and clean or replace the fan motor in accordance.

As for the details of the content and criteria, refer to Subsection 4.2.

4.1.1 Mechanical Inspection Procedures

If the state of the fan motor is not visible, follow the procedures in Subsection 4.1.2 “Electrical Inspection Procedures, Cleaning and Replacement of the Fan Motor”.

If the state is visible, check the state of rotation.

Check if the fan motor is rotating or not when the power is on and follow the procedures below.

1) If the Fan Motor is Rotating

Go on to Subsection 4.1.2 “Electrical Inspection Procedures, Cleaning and Replacement of the Fan Motor” and follow the procedures.

If the fan motor is clogged with foreign materials such as dust and metal chips, spindle motor’s cooling will be insufficient and may cause failure and trouble. If there is a visible foreign materials, please clean the fan motor following the procedures in Subsection 4.2 “Cleaning of the Fan Motor”.

2) If the Fan Motor is not Rotating

Replace the fan motor following the procedure in Subsection 4.2 “Replacement of the Fan Motor”

				TITLE	Cleaning/ Inspection Procedures for Fan Motor of Spindle Motor	
				DRAW. No.	B-65272EN/08-09 B-65285EN/04-05 B-65312EN/05-03 B-65325EN/02-02 B-65452EN/03-04 B-65515EN/01-03	CUST
01	12.Nov.19	Mukai	Newly designed	Hayahi		
Ed.	Date	Design	Description	FANUC CORPORATION	SHEET	4/10

4.1.2 Electrical Inspection Procedures, Cleaning and Replacement of the Fan Motor

Follow the procedures below and clean or replace the fan motor in accordance.

As for the details of the content and criteria, refer to Subsection 4.2.

Measurement inside the control cabinet

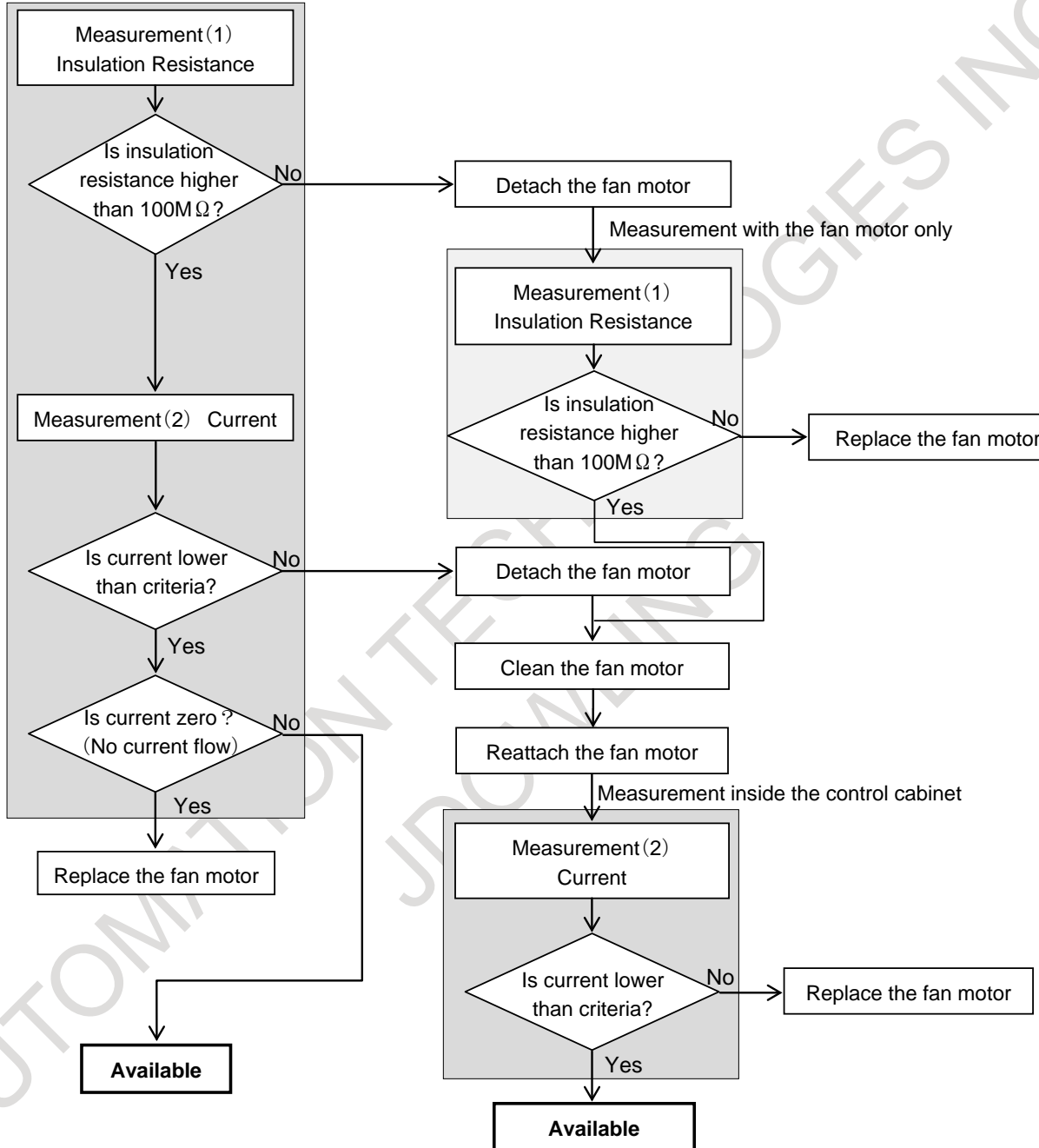

※ Please contact FANUC if there is any question regarding the contents of this report. FANUC service department will conduct inspection at your request so please contact FANUC if necessary.

Ed.	Date	Design	Description	TITLE	CUST
				Cleaning/ Inspection Procedures for Fan Motor of Spindle Motor	
				DRAW. No. B-65272EN/08-09 B-65285EN/04-05 B-65312EN/05-03 B-65325EN/02-02 B-65452EN/03-04 B-65515EN/01-03	
01	12.Nov.19	Mukai	Newly designed Hayahi		
				FANUC CORPORATION	SHEET 5/10

4.2 Work Descriptions and Criteria for Cleaning and Inspection

- ※ If you do not own an insulation resistance meter and a clamp meter necessary for the following measurements, confirm that the fan motor is rotating correctly by vision. If the fan motor is found to be not clean, follow the procedures “Cleaning of the Fan Motor”.

Measurement (1) Insulation Resistance

Instrument : insulation resistance meter (DC500V)

Point : breaker or terminal block inside the control cabinet of the machine

Method :

- ① Turn off the power of the machine.
- ② Measure the insulation resistance using the terminal on the breaker or terminal block connected to power leads of the fan motor.
Measure between one of the three power leads and ground.

Criteria : No failure if the insulation resistance is above 100MΩ.

- ※ If the fan motor is sharing the same breaker with other equipment, measure the insulation resistance between the power leads of fan motor and the ground wire by isolating the power leads of fan motor or isolating the fan motor.

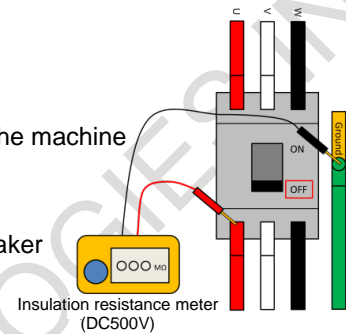

Measurement (2) Current

Instrument : clamp meter

Point : power leads of fan motor inside the control cabinet of the machine

Method :

- ① Attach a clamp meter to one of the power leads of the fan motor.
- ② Turn on the power of the fan motor.
- ③ Measure the current flowing to the fan motor.

Criteria : No failure if the current is below the critical value shown in the chart below (i.e. 20% higher than the rated current), and above zero.

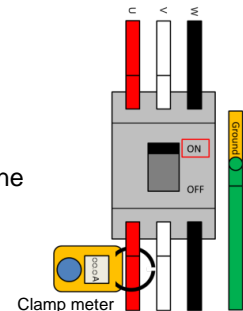

⚠ WARNING

- The measurement is done while the power is on. Take enough safety measures to prevent electric shock.

					TITLE	
					Cleaning/ Inspection Procedures for Fan Motor of Spindle Motor	
					DRAW. No.	CUST
					B-65272EN/08-09 B-65285EN/04-05 B-65312EN/05-03 B-65325EN/02-02 B-65452EN/03-04 B-65515EN/01-03	
01	12.Nov.19	Mukai	Newly designed	Hayahi		
Ed.	Date	Design	Description		FANUC CORPORATION	SHEET
						6/10

Current Criteria (α I-B, β I-B Series)

For model series aside from α I-B and β I-B, contact FANUC sales department or service department.

α I-B, α I _P -B, α I _T -B, α I _{PT} -B, β I-B, β I _P -B, β I _T -B Series 200V Type	50Hz		60Hz	
	Rated Current [A]	Critical Value [A]	Rated Current [A]	Critical Value [A]
α I 1-B, α I 1.5-B, α I _T 1-B, α I _T 1.5-B	0.09	0.11	0.10	0.12
α I 2-B, α I 3-B, α I _T 2-B, α I _T 3-B, β I 3-B, β I 6-B, β I _C 3-B, β I _C 6-B	0.09	0.11	0.10	0.12
α I 6-B, α I 8-B, α I _T 6-B, α I _T 8-B, β I 8-B, β I 12-B, β I _P 12-B, β I _T 12-B, β I _C 8-B	0.13	0.16	0.14	0.17
α I 12-B~ α I 22-B, α I _P 12-B~ α I _P 22-B, α I _T 12-B~ α I _T 22-B, α I _{PT} 22-B, β I 15-B, β I _P 15-B~ β I _P 30-B, β I _T 15-B	0.20	0.24	0.30	0.36
α I 30-B, α I 40-B, α I _P 30-B, α I _P 40-B, α I _P 50-B, β I _P 40-B	0.45	0.54	0.48	0.58
α I 50-B, α I 60-B, α I _P 60-B	0.42	0.50	0.55	0.66

α I-B, α I _P -B, α I _T -B, β I-B, β I _T -B Series 400V Type	50Hz		60Hz	
	Rated Current [A]	Critical Value [A]	Rated Current [A]	Critical Value [A]
α I 1HV-B, α I 1.5HV-B, α I _T 1.5HV-B	0.09	0.11	0.11	0.13
α I 2HV-B, α I 3HV-B, α I _T 2HV-B, α I _T 3HV-B, β I 3HV-B, β I 6HV-B,	0.11	0.13	0.13	0.16
α I 6HV-B, α I 8HV-B, α I _T 6HV-B, α I _T 8HV-B, β I 8HV-B, β I 12HV-B	0.07	0.08	0.08	0.10
α I 12HV-B~ α I 22HV-B, α I _P 15HV-B, α I _P 22HV-B, α I _T 15HV-B, α I _T 22HV-B, β I 15HV-B	0.15	0.18	0.16	0.19
α I 30HV-B, α I 40HV-B, α I _P 40HV-B, α I _P 50HV-B	0.22	0.26	0.26	0.31
α I 50HV-B, α I 60HV-B, α I _P 60HV-B	0.22	0.26	0.28	0.34
α I 75HV-B, α I 100HV-B	0.30	0.36	0.36	0.43
α I 150HV-B	0.70	0.84	1.2	1.44

; α I, β I series are similar to the above.

Ed.	Date	Design	Description	FANUC CORPORATION	SHEET
01	12.Nov.19	Mukai	Newly designed Hayahi	TITLE Cleaning/ Inspection Procedures for Fan Motor of Spindle Motor DRAW. No. B-65272EN/08-09 B-65285EN/04-05 B-65312EN/05-03 B-65325EN/02-02 B-65452EN/03-04 B-65515EN/01-03	CUST 7/10

Detaching the Fan Motor

- ① Unscrew the 4 bolts on the terminal box and remove the lid of terminal box.



4 bolts

Lid of terminal box



Inside the terminal box

Terminal box of the motor

- ② Detach the power leads of fan motor from terminal block and ground wire from ground, both located inside the terminal box.

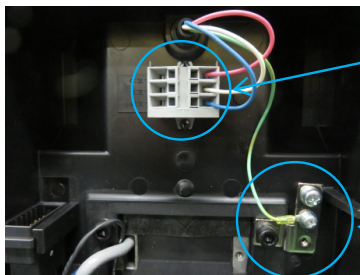

Terminal box

Ground



- ③ Unscrew the 4 bolts on the fan motor and detach the fan motor from the spindle motor. During this operation, be careful not to detach the rubber bushing from the terminal box hole.



4 bolts

Rubber bushing



					TITLE	
					Cleaning/ Inspection Procedures for Fan Motor of Spindle Motor	
					DRAW. No.	CUST
					B-65272EN/08-09 B-65285EN/04-05 B-65312EN/05-03 B-65325EN/02-02 B-65452EN/03-04 B-65515EN/01-03	
01	12.Nov.19	Mukai	Newly designed	Hayahi		
Ed.	Date	Design	Description		FANUC CORPORATION	SHEET 8/10

Cleaning of the Fan Motor

- ① Blow off the sludge accumulated around the fan motor by blowing compressed air.
If the sludge cannot be blown off, please replace the fan motor.



Air blower

- ② Blow compressed air from the space between bell mouth and impeller and blow off the sludge accumulated inside of the fan motor.

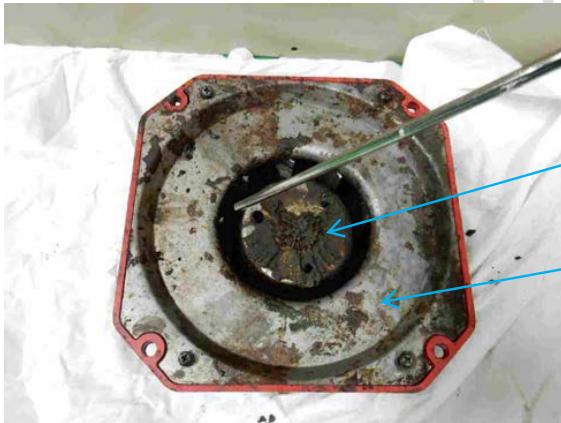

Impeller

Bell mouth



Blown off sludge

				TITLE	
				Cleaning/ Inspection Procedures for Fan Motor of Spindle Motor	
				DRAW. No.	CUST
				B-65272EN/08-09	
				B-65285EN/04-05	
				B-65312EN/05-03	
				B-65325EN/02-02	
				B-65452EN/03-04	
				B-65515EN/01-03	
01	12.Nov.19	Mukai	Newly designed	Hayahi	
Ed.	Date	Design	Description	FANUC CORPORATION	SHEET 9/10

Reattaching the Fan Motor

- ① Pull the power leads of the fan motor through the rubber bushing and draw them into the terminal box. Spraying lubricant on the rubber tube of the power leads will make the operation easier.
- ② Fix the fan motor on the spindle motor with 4 bolts.
On tightening the bolts, control the torque to the correct value. (Tightening torque: 2.8~4.0Nm)
- ③ Connect the power leads to the terminal block and ground wire to the ground in the terminal box.

Power leads wiring of the fan motor

The fan motor has 3 power leads and 1 ground wire.

Wire the power leads to the terminals FMU, FMV and FMW printed on the terminal block in the terminal box or imprinted on the terminal box.

Wire the ground wire to the screw with the ground mark.

Type and color	Connection point
Power lead (Red)	terminal FMU
Power lead (White)	terminal FMV
Power lead (Blue or black)	terminal FMW
Ground wire (Green and yellow)	Screw of the ground terminal

- ④ Fix the lid on the terminal box with 4 bolts.
On tightening the bolts, control the torque to the correct value. (Tightening torque: 2.8~4.0Nm)
- ⑤ Verify that the fan motor is rotating in the correct direction by vision right after the power is put on or right after the power is shut off.



Fan cover

The correct direction of the fan motor rotation

Replacement of the Fan Motor

- ① Detach the fan motor following the procedures in “Detaching the Fan Motor”.
- ② Have a replacement fan motor at hand and attach the new fan motor following the procedures in “Reattaching the Fan Motor”.

※ If a replacement fan is not available soon enough, make sure to shut off the power by dropping the breaker or disconnecting the power leads on the fan motor as a temporary treatment until the fan motor is replaced.

Ed.	Date	Design	Description	TITLE	SHEET
01	12.Nov.19	Mukai	Newly designed Hayahi	Cleaning/ Inspection Procedures for Fan Motor of Spindle Motor	10/10
				DRAW. No. B-65272EN/08-09 B-65285EN/04-05 B-65312EN/05-03 B-65325EN/02-02 B-65452EN/03-04 B-65515EN/01-03	CUST
				FANUC CORPORATION	10/10

Cautions for replacing the fan motor of the servo amplifier

1.Type of applied technical documents

Name	FANUC AC SERVO MOTOR αi series FANUC AC SPINDLE MOTOR αi series FANUC SERVO AMPLIFIER αi series MAINTENANCE MANUAL FANUC AC SERVO MOTOR βi series FANUC AC SPINDLE MOTOR βi series FANUC SERVO AMPLIFIER βi series MAINTENANCE MANUAL FANUC SERVO AMPLIFIER βi series I/O Link Option MAINTENANCE MANUAL FANUC AC SERVO MOTOR βi -B / βi series FANUC AC SPINDLE MOTOR βi -B series FANUC SERVO AMPLIFIER βi -B series MAINTENANCE MANUAL FANUC SERVO AMPLIFIER βi -B series I/O Link Option MAINTENANCE MANUAL FANUC AC SERVO MOTOR αi -B / αi series FANUC AC SPINDLE MOTOR αi -B series FANUC SERVO AMPLIFIER αi -B series FANUC AC SERVO MOTOR βi -B / βi series FANUC AC SPINDLE MOTOR βi -B series FANUC SERVO AMPLIFIER βi -B series MAINTENANCE MANUAL
Spec.No./Ed.	B-65285EN/04 B-65325EN/02 B-65395EN/02 B-65425EN/02 B-65435EN/02 B-65515EN/01

								Title	Cautions for replacing the fan motor of the servo amplifier		
								Draw No.	B-65285EN/04-06,B-65325EN/02-03,B-65395EN/02-01, B-65425EN/02-02,B-65435EN/02-01,B-65515EN/01-04		
Ed.	Date	Design	Description						FANUC CORPORATION	Sheet.	1/3
Date	20.01.17	Desig.	Yamamoto	Check		Apprv.					

2.Summary of Change

Group	Name/Outline	New, Add, Correct, Delete	Applicable Date
Basic			
Optional Function			
Unit			
Maintenance Parts			
Notice	Cautions for replacing the fan motor of the servo amplifier	Add	Jan.2020
Correction			
Another			

				Title. Cautions for replacing the fan motor of the servo amplifier	
				Draw.No. B-65285EN/04-06,B-65325EN/02-03,B-65395EN/02-01, B-65425EN/02-02,B-65435EN/02-01,B-65515EN/01-04	CUST.
Edit	Date	Design	Description	FANUC CORPORATION	
				Sheet.	2/3

1. Summary

Replacing the fan motor while the power of the machine (control unit) is supplied may result in failure of the servo amplifier. Therefore, we add cautions when replacing the fan motor of the servo amplifier.

2. Cautions for replacing the fan motor of the servo amplifier

⚠ WARNING

When replacing the fan motor of the servo amplifier, be sure to turn off the power of the machine (control unit).

Replacing the fan motor while the main power or control power is supplied may result in failure of the fan motor or the servo amplifier, and a risk of electric shock.

Because the amplifier uses a large-capacitance electrolytic capacitor internally, the amplifier remains charged for a while even after the power is turned off. Before touching the servo amplifier for maintenance or other purposes, ensure your safety by measuring the residual voltage in the DC link with a tester and confirming that the charge indication LED (red) is off.

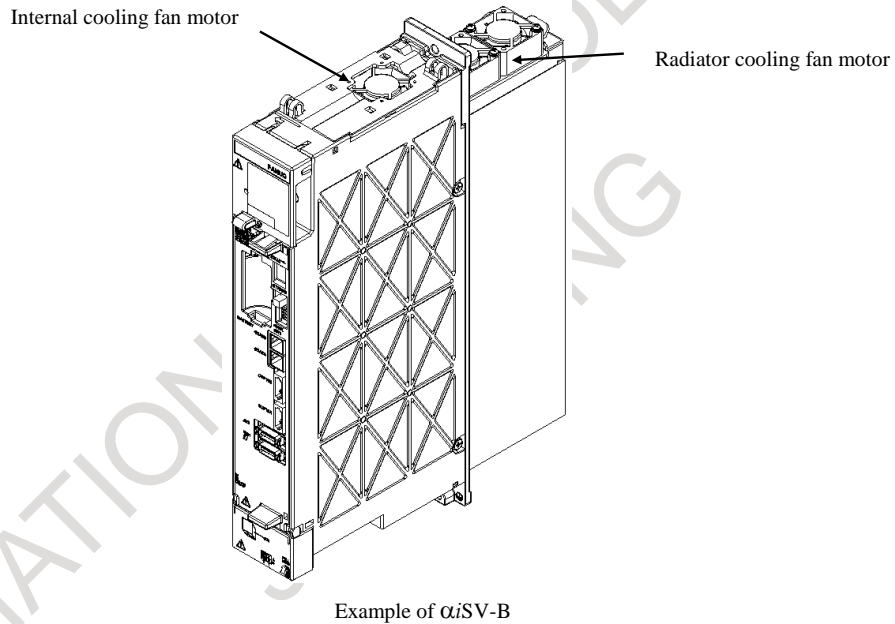

					Title. Cautions for replacing the fan motor of the servo amplifier
					Draw.No. B-65285EN/04-06, B-65325EN/02-03, B-65395EN/02-01, B-65425EN/02-02, B-65435EN/02-01, B-65515EN/01-04
					CUST.
Edit	Date	Design	Description	FANUC CORPORATION	Sheet. 3/3

JR AUTOMATION TECHNOLOGIES INC*
JDOWLING

INDEX

< α >

α M sensor, α i MZ sensor, and α i BZ sensor	80
α position coder S	81

<A>

A specified speed cannot be obtained.	69
About the spindle control and spindle status signals	76
Alarm Code "-" Flashing	101
Alarm Code 01 (SP9001)	110
Alarm Code 02 (SP9002)	111
Alarm Code 03 (SP9003)	111
Alarm Code 06 (SP9006)	112
Alarm Code 07 (SP9007)	112
Alarm Code 09 (SP9009)	112
Alarm Code 10 (SP9010)	113
Alarm Code 12 (SP9012)	113
Alarm Code 13 (SP9013)	114
Alarm Code 14 (SP9014)	114
Alarm Code 15 (SP9015)	114
Alarm Code 16 (SP9016)	114
Alarm Code 17 (SP9017)	115
Alarm Code 18 (SP9018)	115
Alarm Code 21 (SP9021)	115
Alarm Code 22 (SP9022)	115
Alarm Code 24 (SP9024)	115
Alarm Code 27 (SP9027)	116
Alarm Code 29 (SP9029)	117
Alarm Code 31 (SP9031)	118
Alarm Code 32 (SP9032)	118
Alarm Code 34 (SP9034)	118
Alarm Code 35 (SP9035)	119
Alarm Code 36 (SP9036)	119
Alarm Code 37 (SP9037)	120
Alarm Code 41 (SP9041)	120
Alarm Code 42 (SP9042)	121
Alarm Code 43 (SP9043)	121
Alarm Code 46 (SP9046)	121
Alarm Code 47 (SP9047)	121
Alarm Code 49 (SP9049)	122
Alarm Code 50 (SP9050)	122
Alarm Code 54 (SP9054)	122
Alarm Code 55 (SP9055)	123
Alarm Code 56 (SP9056)	123
Alarm Code 61 (SP9061)	123
Alarm Code 66 (SP9066)	124
Alarm Code 67 (SP9067)	124
Alarm Code 68 (SP9068)	124
Alarm Code 69 (SP9069)	124
Alarm Code 70 (SP9070)	124
Alarm Code 71 (SP9071)	124
Alarm Code 72 (SP9072)	125
Alarm Code 73 (SP9073)	125
Alarm Code 74 (SP9074)	126
Alarm Code 75 (SP9075)	126

Alarm Code 76 (SP9076)	126
Alarm Code 77 (SP9077)	126
Alarm Code 78 (SP9078)	126
Alarm Code 79 (SP9079)	126
Alarm Code 81 (SP9081)	126
Alarm Code 82 (SP9082)	127
Alarm Code 83 (SP9083)	128
Alarm Code 84 (SP9084)	128
Alarm Code 85 (SP9085)	129
Alarm Code 86 (SP9086)	129
Alarm Code 87 (SP9087)	129
Alarm Code 88 (SP9088)	129
Alarm Code 92 (SP9092)	129
Alarm Code b0 (SP9110)	130
Alarm Code C3 (SP9123)	130
Alarm Code C8 (SP9128)	131
Alarm Code C9 (SP9129)	131
Alarm Code d1 (SP9131)	131
Alarm Code d2 (SP9132)	131
Alarm Code d3 (SP9133)	131
Alarm Code d4 (SP9134)	132
Alarm Code d6 (SP9136)	132
Alarm Code d7 (SP9137)	132
Alarm Code d8 (SP9138)	132
Alarm Code d9 (SP9139)	132
Alarm Code E0 (SP9140)	132
Alarm Code E1 (SP9141)	133
Alarm Code E2 (SP9142)	133
Alarm Code F8 (SP9158)	133
Alarm Code G6 (SP9166)	133
Alarm Code G7 (SP9167)	133
Alarm Code L	103
Alarm Codes 19 and 20 (SP9019, SP9020)	115
Alarm Codes 52 and 53 (SP9052, SP9053)	122
Alarm Codes A, A1, A2	130
Alarm Codes C0, C1, and C2 (SP9120, SP9121, and SP9122)	130
ALARM NUMBERS AND BRIEF DESCRIPTIONS	20,90
Alarms for built-in detectors (α i and β i Pulsecoders) and troubleshooting actions	156
Alarms for separate detectors and troubleshooting actions	156
Alarms Related to Pulsecoder and Separate Serial Detector	33,107
An overshoot or hunting occurs.	70
Appearance inspection of the linear motor (magnet plate)	155

Battery connection modes	43,140
--------------------------------	--------

<C>

Caution	s-11,s-13,s-5,s-9
Check Procedure	10

Check Terminal on the Printed-circuit Board	67	For the Radiator Cooling Fan Motor: β iSV40, β iSV80, β iSV10HV, β iSV20HV, β iSV40HV	39
Check terminal output signals	78	FSSB Communication Error	28
Checking Method when Magnetic Contactor Is not Switched On	66	Fuse Locations	50,144
Checking parameters	179		
CHECKING PARAMETERS USING THE SPINDLE		<H>	
CHECK BOARD	179	How to Replace the Fuses and Printed Circuit Boards...47	
Checking the Feedback Signal Waveform	80	HOW TO REPLACE THE FUSES AND PRINTED CIRCUIT BOARDS	47,143
Checking the STATUS 2 Indicator	82	How to Replace the Fuses and Printed Circuit Boards. 143	
Checking the Voltage and Capacity of the Power.....	7,58		
COMMON TO SERVO AND SPINDLE UNITS.....	96	<I>	
CONFIGURATIONS	4,54	α i CZ sensor.....	81
CONFIRMATION OF THE OPERATION	10,62	INITIALIZING PARAMETERS	61
Connecting a Protective Ground	8,60	INITIALIZING PARAMETERS (SWITCHES AND DUMMY CONNECTORS)	9
Connecting the battery for the β series motor	45	INITIALIZING SETTINGS	9
CONNECTING THE POWER	7,58	Invalid Servo Parameter Setting Alarm.....	32,107
Connector and STATUS LED Locations	62	Inverter: Cooling Fan Stopped of the Radiator	26
Converter: Control Power Supply Undervoltage.....	26	Inverter: Internal Cooling Fan Stopped.....	26
Converter: DC Link Overvoltage	25	Inverter: IPM Alarm.....	26
Converter: DC Link Undervoltage	24	Inverter: IPM Alarm (OH)	27
Converter: Excessive Deceleration Power	25	Inverter: Motor Current Alarm.....	27
Cutting power weakens or acceleration/deceleration slows down.....	70	β iSVSP.....	55
		β iSVSP COMMON POWER SUPPLY UNIT.....	66
		β iSVSP SERVO UNIT	82
		β iSVSP SPINDLE UNIT	68
		β iSVSPc.....	56
<D>		<L>	
Data Numbers	177	LIST OF MANUALS RELATED TO MOTORS AND AMPLIFIERS.....	148
DEFINITION OF WARNING, CAUTION, AND NOTE	s-2	List of spindle data that can be observed using the SERVO GUIDE	75
Descriptions and Initial Values of Addresses.....	174		
Detailed troubleshooting methods.....	158	<M>	
Diagnosis Screen.....	30,104	Main Characteristics	173
Display of the servo amplifier operation status	164	Main inspection items	151
		Maintenance of β iS servo motor (\square 40 and \square 60) Pulsecoders.....	159
		Maintenance of a Detector	155
		Maintenance of a Servo Amplifier	164
		MAJOR COMPONENTS	5,55
		MEASURING SERVO MOTOR WAVEFORMS (TCMD, VCMD).....	171
		Method for Observing Motor Current	14,84
		MOTOR/DETECTOR/AMPLIFIER PREVENTIVE MAINTENANCE.....	147
		<N>	
		Note.....	s-10,s-13,s-6
		Notes on attaching connectors	45
		Notes on Attaching Connectors.....	142
		Notes on motor cleaning	154
		Notes on Replacing a Battery (Supplementary Explanation)	43,140
		Notes on the cutting fluid (informational).....	154
<E>			
Example of observing data	77		
Examples of Observing Data.....	178		
External Cooling Fan Motor	136		
<F>			
FANUC AC SERVO MOTOR βi series, FANUC AC SPINDLE MOTOR βi series	s-3		
FANUC SERVO AMPLIFIER βi series	s-8		
Feedback Disconnected Alarm.....	31,106		
For Series $0i/0i$ Mate-B,C	93		
FOR Series $0i/0i$ Mate-D.....	21		
For Series $0i/0i$ Mate-D.....	90		
FOR Series $15i$	22		
FOR Series $16i$, $18i$, $20i$, $21i$, $0i$, AND Power Mate i	23		
FOR Series $30i/31i/32i/35i$ -B, Power Motion i -A.....	20		
FOR Series $30i/31i/32i$ -A.....	20		
For the Internal Cooling Fan Motor: β iSV20/20, β iSV40/40	38		
For the Internal Cooling Fan Motor: β iSV4, β iSV20.....	36		
For the Internal Cooling Fan Motor: β iSV40, β iSV80, β iSV10HV, β iSV20HV, β iSV40HV	37		
For the Internal Cooling Fan Motor: Model β iSVSP*-18 Only.....	135		

<O>

Observation Method.....	173
Observing Data Using the SERVO GUIDE.....	74
OBSERVING DATA USING THE SPINDLE CHECK BOARD.....	173
Other Alarms.....	34,109,134
OUTLINE OF β iSVSP.....	62
Overheat Alarm.....	32,106
Overload Alarm (Soft Thermal, OVC).....	30,105
OVERVIEW.....	3,19,53,89
Overview.....	40,74,137,173,179

<P>

Periodic cleaning of a motor.....	154
PREFACE.....	p-1
Preventive Maintenance of a Linear Motor.....	155
Preventive Maintenance of a Motor (Common to All Models).....	151
Preventive Maintenance of a Servo Amplifier.....	163
PREVENTIVE MAINTENANCE OF MOTORS AND DETECTORS.....	149
PREVENTIVE MAINTENANCE OF SERVO AMPLIFIERS.....	160
Principles in Outputting the Internal Data of the Spindle.....	174
Pulsecoder.....	167

<R>

REPLACEMENT OF A FAN MOTOR.....	36,135
Replacement of a fan motor.....	164
Replacing Batteries.....	40,137
REPLACING BATTERY FOR ABSOLUTE PULSECODERS.....	40,137,164
REPLACING SERVO AMPLIFIER COMPONENTS.....	36,135
Replacing the Batteries in a Separate Battery Case.....	41,138
Replacing the Battery Built into the Servo Amplifier.....	41,138

<S>

SAFETY PRECAUTIONS.....	s-1
Selecting the Ground Fault Interrupter That Matches the Leakage Current.....	8,60
Servo Adjustment Screen.....	28
Servo Alarm.....	20,21,22,23,90,93
Servo Amplifier.....	5
SERVO AMPLIFIER MODULE.....	10,24
SERVO MOTOR MAINTENANCE.....	167
SERVO MOTOR MAINTENANCE PARTS.....	167
SERVO SOFTWARE.....	28,103
Servo Tuning Screen.....	103
SERVO UNIT.....	98
Setting Data to Be Observed.....	173
Spindle Alarm.....	91,94
Spindle Check Board.....	78
Spindle check board connection.....	78
Spindle check board specifications.....	78
SPINDLE MOTOR MAINTENANCE PARTS.....	168

SPINDLE UNIT.....	110
START-UP PROCEDURE.....	6,57
Start-up Procedure.....	65
START-UP PROCEDURE (OVERVIEW).....	6,57
STATUS 1 Indicator.....	68
Status Error Indication Function.....	71
STATUS2 Alarm Code - STATUS1 Alarm Code 04 (SP9004).....	96
STATUS2 Alarm Code - STATUS1 Alarm Code 11 (SP9011).....	96
STATUS2 Alarm Code - STATUS1 Alarm Code 30 (SP9030).....	96
STATUS2 Alarm Code - STATUS1 Alarm Code 33 (SP9033).....	96
STATUS2 Alarm Code - STATUS1 Alarm Code 51 (SP9051).....	97
STATUS2 Alarm Code - STATUS1 Alarm Code 58 (SP9058).....	97
STATUS2 Alarm Code - STATUS1 Alarm Code 59 (SP9059).....	97
STATUS2 Alarm Code - STATUS1 Alarm Code b1 (SP9111).....	98
STATUS2 Alarm Code 1 (SV0444).....	99
STATUS2 Alarm Code 2 (SV0434).....	99
STATUS2 Alarm Code 5 (SV0435).....	99
STATUS2 Alarm Code 6 (SV0602).....	99
STATUS2 Alarm Code 8 , 9 , A. (SV0449).....	100
STATUS2 Alarm Code 8 , 9 , A. (SV0603).....	100
STATUS2 Alarm Code b , c , d (SV0438).....	100
STATUS2 Alarm Code P (SV0604).....	100
STATUS2 Alarm Code U.....	102

<T>

The LED (STATUS Indicator) Is Off.....	66
The motor does not turn.....	69
The STATUS 1 indicator is blinking with "--".....	69
TROUBLESHOOTING AND ACTION.....	24,96
Troubleshooting at Startup.....	69

<U>

Usable series and editions.....	74
USING THE SPINDLE CHECK BOARD.....	173

<V>

VRDY-OFF Alarm Indicated on the CNC Screen	12,82
---	-------

<W>

Warning.....	s-10,s-12,s-3,s-8
Warnings and Cautions Relating to a Pilot Run.....	s-10
Warnings and Cautions Relating to Maintenance.....	s-12
Warnings and Cautions Relating to Mounting.....	s-8
Warnings, Cautions, and Notes on Operation of Servo Amplifiers.....	160
Warnings, Cautions, and Notes on Preventive Maintenance of Motors and Detectors.....	149
When cutting is not performed, the spindle vibrates, making noise.....	70

JR AUTOMATION TECHNOLOGIES INC*
JDOWLING

REVISION RECORD

Edition	Date	Contents
02	Jul., 2013	Total revision
01	Sep., 2003	

JR AUTOMATION TECHNOLOGIES INC*
JDOWLING

JR AUTOMATION TECHNOLOGIES INC*
JDOWLING

B-65325EN/02



* B - 6 5 3 2 5 E N / 0 2 . 0 2 *