

FANUC 1-axis SERVO POSITIONER

MECHANICAL UNIT MAINTENANCE MANUAL

B-82545EN/06

- **Original Instructions**

Thank you very much for purchasing FANUC Robot.

Before using the Robot, be sure to read the "FANUC Robot SAFETY HANDBOOK (B-80687EN)" and understand the content.

This manual can be used with controllers labeled R-30iA or R-J3iC. If you have a controller labeled R-J3iC, you should read R-30iA as R-J3iC throughout this manual.

- No part of this manual may be reproduced in any form.
- The appearance and specifications of this product are subject to change without notice.

The products in this manual are controlled based on Japan's "Foreign Exchange and Foreign Trade Law". The export from Japan may be subject to an export license by the government of Japan. Further, re-export to another country may be subject to the license of the government of the country from where the product is re-exported. Furthermore, the product may also be controlled by re-export regulations of the United States government. Should you wish to export or re-export these products, please contact FANUC for advice.

In this manual, we endeavor to include all pertinent matters. There are, however, a very large number of operations that must not or cannot be performed, and if the manual contained them all, it would be enormous in volume. It is, therefore, requested to assume that any operations that are not explicitly described as being possible are "not possible".

SAFETY PRECAUTIONS

This chapter describes the precautions which must be followed to ensure the safe use of the robot. Before using the robot, be sure to read this chapter thoroughly.

For detailed functions of the robot operation, read the relevant operator's manual to understand fully its specification.

For the safety of the operator and the system, follow all safety precautions when operating a robot and its peripheral equipment installed in a work cell.

In addition, refer to the "FANUC Robot SAFETY HANDBOOK (B-80687EN)".

1 DEFINITION OF USER

The user can be defined as follows.

Operator:

- Turns ON/OFF power to the robot
- Starts the robot program from the operator's panel

Programmer:

- Operates the robot
- Teaches the robot inside the safety fence

Maintenance engineer:

- Operates the robot
- Teaches the robot inside the safety fence
- Performs maintenance (repair, adjustment, replacement)



- Operator is not allowed to work in the safety fence.
- Programmers and maintenance engineers are allowed to work in the safety fence. The work inside the safety fence includes lifting, setting, teaching, adjustment, maintenance, etc.
- To work inside the safety fence, the person must receive a professional training for the robot.

During the operation, programming, and maintenance of your robotic system, the programmer, operator, and maintenance engineer should take additional care of their safety by wearing the following safety items.

- Adequate clothes for the operation
- Safety shoes
- A helmet

2 DEFINITION OF SAFETY NOTATIONS

To ensure the safety of users and prevent damage to the machine, this manual indicates each precaution on safety with "WARNING" or "CAUTION" according to its severity. Supplementary information is indicated by "NOTE". Read the contents of each "WARNING", "CAUTION" and "NOTE" before using the robot.

Symbol	Definitions
 WARNING	Used if hazard resulting in the death or serious injury of the user will be expected to occur if he or she fails to follow the approved procedure.
 CAUTION	Used if a hazard resulting in the minor or moderate injury of the user, or equipment damage may be expected to occur if he or she fails to follow the approved procedure.
NOTE	Used if a supplementary explanation not related to any of WARNING and CAUTION is to be indicated.

- Check this manual thoroughly, and keep it handy for the future reference.

3 SAFETY OF THE USER

User safety is the primary safety consideration. Because it is very dangerous to enter the operating space of the robot during automatic operation, adequate safety precautions must be observed. The following lists the general safety precautions. Careful consideration must be made to ensure user safety.

- (1) Have the robot system users attend the training courses held by FANUC.

FANUC provides various training courses. Contact our sales office for details.

- (2) Even when the robot is stationary, it is possible that the robot is still in a ready to move state, and is waiting for a signal. In this state, the robot is regarded as still in motion. To ensure user safety, provide the system with an alarm to indicate visually or aurally that the robot is in motion.
- (3) Install a safety fence with a gate so that no user can enter the work area without passing through the gate. Install an interlocking device, a safety plug, and so forth in the safety gate so that the robot is stopped as the safety gate is opened.

The controller is designed to receive this interlocking signal of the door switch. When the gate is opened and this signal received, the controller stops the robot (Please refer to "STOP TYPE OF ROBOT" in "SAFETY PRECAUTIONS" for detail of stop type). For connection, see Fig. 3 (b).

- (4) Provide the peripheral equipment with appropriate earth (Class A, Class B, Class C, and Class D).
- (5) Try to install the peripheral equipment outside the robot operating space.
- (6) Draw an outline on the floor, clearly indicating the range of the robot operating space, including the tools such as a hand.
- (7) Install a mat switch or photoelectric switch on the floor with an interlock to a visual or aural alarm that stops the robot when a user enters the work area.
- (8) If necessary, install a safety lock so that no one except the user in charge can turn on the power of the robot.

The circuit breaker installed in the controller is designed to disable anyone from turning it on when it is locked with a padlock.

- (9) When adjusting each peripheral equipment independently, be sure to turn off the power of the robot.
- (10) Operators should be ungloved while manipulating the operator panel or teach pendant. Operation with gloved fingers could cause an operation error.
- (11) Programs, system variables, and other information can be saved on memory card or USB memories. Be sure to save the data periodically in case the data is lost in an accident. (refer to Controller OPERATOR'S MANUAL.)
- (12) The robot should be transported and installed by accurately following the procedures recommended by FANUC. Wrong transportation or installation may cause the robot to fall, resulting in severe injury to workers.
- (13) In the first operation of the robot after installation, the operation should be restricted to low speeds. Then, the speed should be gradually increased to check the operation of the robot.
- (14) Before the robot is started, it should be checked that no one is inside the safety fence. At the same time, a check must be made to ensure that there is no risk of hazardous situations. If detected, such a situation should be eliminated before the operation.
- (15) When the robot is used, the following precautions should be taken. Otherwise, the robot and peripheral equipment can be adversely affected, or workers can be severely injured.
 - Avoid using the robot in a flammable environment.
 - Avoid using the robot in an explosive environment.
 - Avoid using the robot in an environment full of radiation.
 - Avoid using the robot under water or at high humidity.
 - Avoid using the robot to carry a person or animal.
 - Avoid using the robot as a stepladder. (Never climb up on or hang from the robot.)
 - Outdoor
- (16) When connecting the peripheral equipment related to stop (safety fence etc.) and each signal (external emergency, fence etc.) of robot, be sure to confirm the stop movement and do not take the wrong connection.
- (17) When preparing footstep, please consider security for installation and maintenance work in high place according to Fig. 3 (c). Please consider footstep and safety belt mounting position.

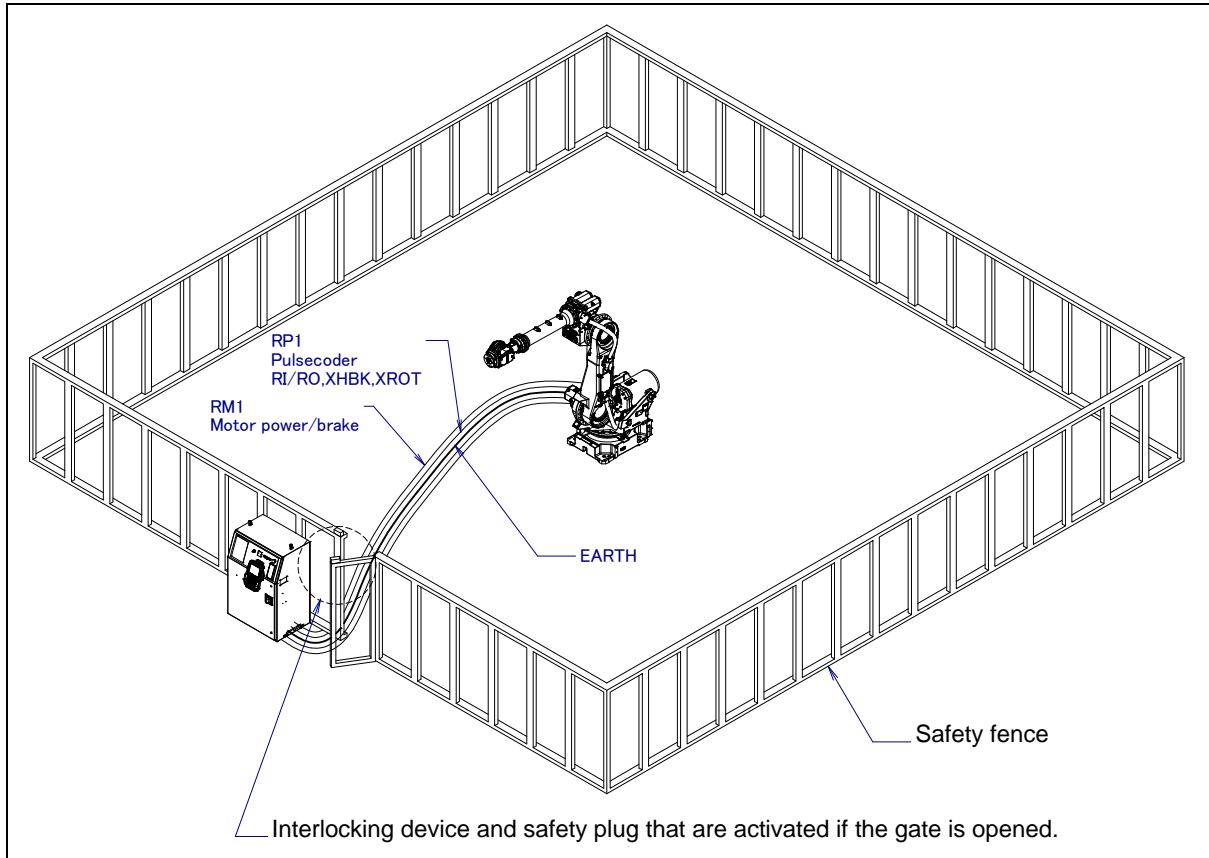

Fig. 3 (a) Safety fence and safety gate



WARNING

When you close a fence, please confirm that there is not a person from all directions of the robot.

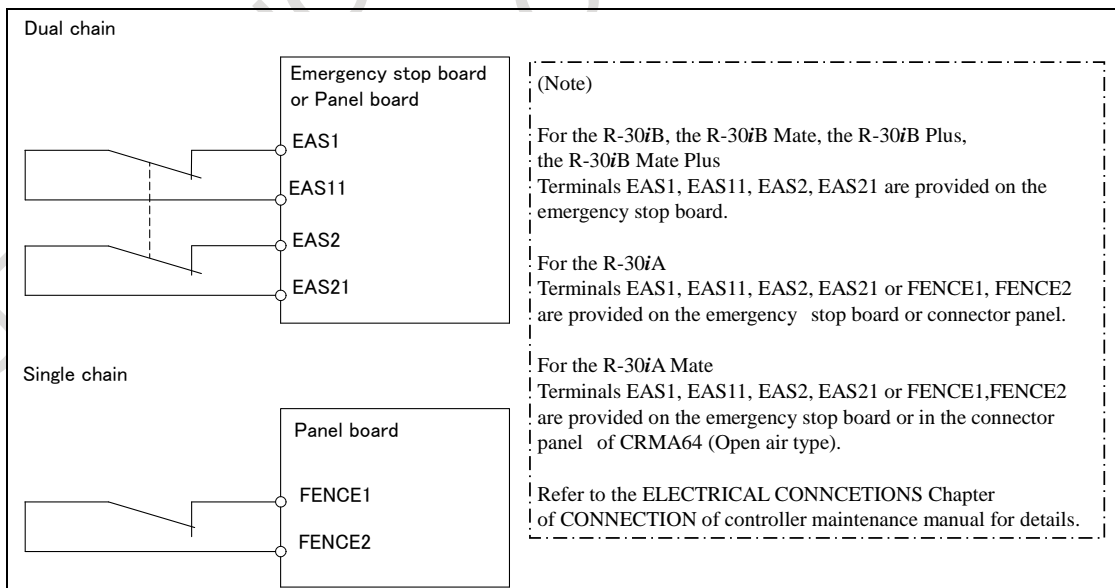

Fig. 3 (b) Connection diagram for the signal of safety fence

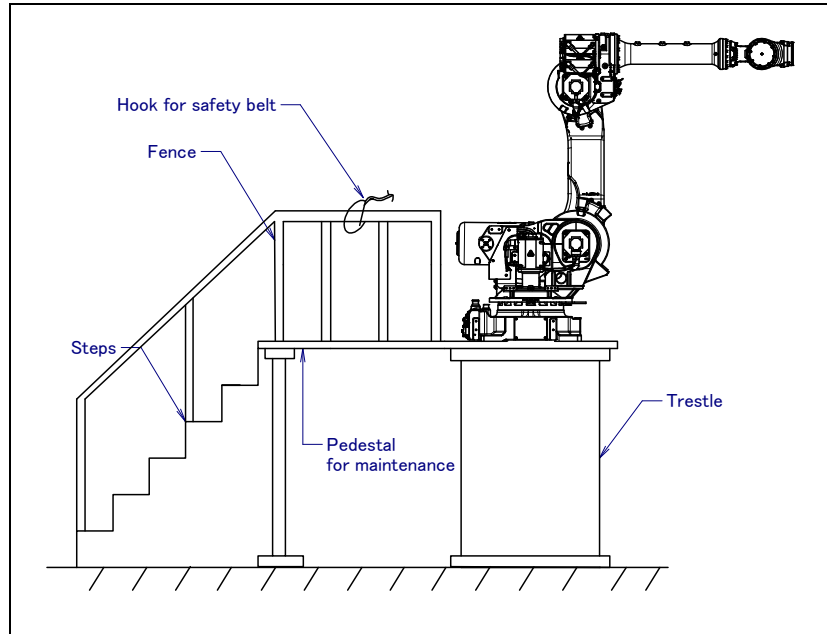

Fig. 3 (c) Pedestal for maintenance

3.1 SAFETY OF THE OPERATOR

An operator refers to a person who turns on and off the robot system and starts a robot program from, for example, the operator panel during daily operation. Operators cannot work inside of the safety fence.

- (1) If the robot does not need to be operated, turn off the robot controller power or press the EMERGENCY STOP button during working.
- (2) Operate the robot system outside the operating space of the robot.
- (3) Install a safety fence or safety door to avoid the accidental entry of a person other than an operator in charge or keep operator out from the hazardous place.
- (4) Install the EMERGENCY STOP button within the operator's reach.

The robot controller is designed to be connected to an external EMERGENCY STOP button. With this connection, the controller stops the robot operation (Please refer to "STOP TYPE OF ROBOT" in "SAFETY PRECAUTIONS" for detail of stop type) when the external EMERGENCY STOP button is pressed. See the diagram below for connection.

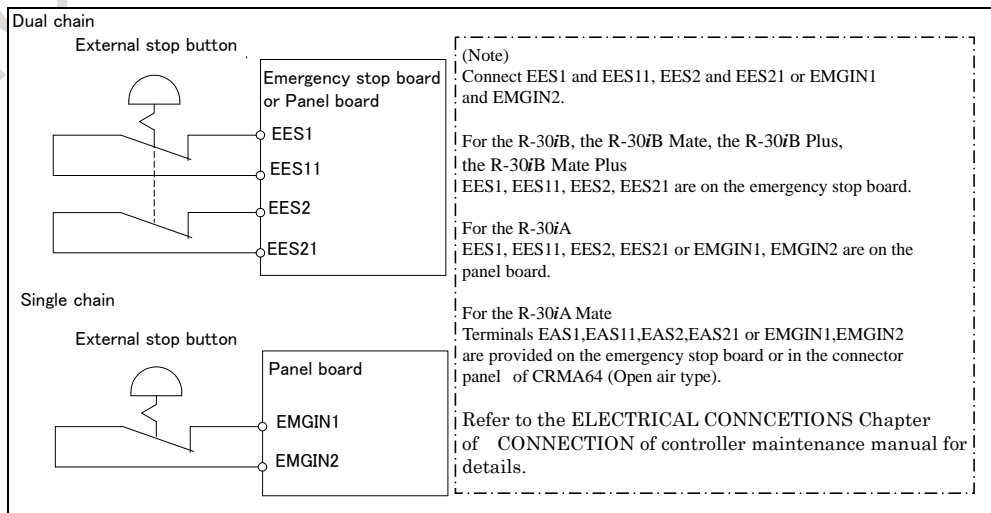

Fig. 3.1 Connection diagram for external emergency stop button

3.2 SAFETY OF THE PROGRAMMER

While teaching the robot, the operator may need to enter the robot operation area. The programmer must ensure the safety especially.

- (1) Unless it is specifically necessary to enter the robot operating space, carry out all tasks outside the operating space.
- (2) Before teaching the robot, check that the robot and its peripheral equipment are all in the normal operating condition.
- (3) If it is inevitable to enter the robot operating space to teach the robot, check the locations, settings, and other conditions of the safety devices (such as the EMERGENCY STOP button, the DEADMAN switch on the teach pendant) before entering the area.
- (4) The programmer must be extremely careful not to let anyone else enter the robot operating space.
- (5) Programming should be done outside the area of the safety fence as far as possible. If programming needs to be done inside the safety fence, the programmer should take the following precautions:
 - Before entering the area of the safety fence, ensure that there is no risk of dangerous situations in the area.
 - Be prepared to press the emergency stop button whenever necessary.
 - Robot motions should be made at low speeds.
 - Before starting programming, check the whole robot system status to ensure that no remote instruction to the peripheral equipment or motion would be dangerous to the user.

Our operator panel is provided with an emergency stop button and a key switch (mode switch) for selecting the automatic operation mode (AUTO) and the teach modes (T1 and T2). Before entering the inside of the safety fence for the purpose of teaching, set the switch to a teach mode, remove the key from the mode switch to prevent other people from changing the operation mode carelessly, then open the safety gate. If the safety gate is opened with the automatic operation mode set, the robot stops (Please refer to "**STOP TYPE OF ROBOT**" in SAFETY PRECAUTIONS for detail of stop type). After the switch is set to a teach mode, the safety gate is disabled. The programmer should understand that the safety gate is disabled and is responsible for keeping other people from entering the inside of the safety fence. (In case of R-30iA Mate Controller standard specification, there is no mode switch. The automatic operation mode and the teach mode is selected by teach pendant enable switch.)

Teach pendant is provided with a switch to enable/disable robot operation from teach pendant and DEADMAN switch as well as emergency stop button. These button and switch function as follows:

- (1) Emergency stop button: Causes the stop of the robot (Please refer to "STOP TYPE OF ROBOT" in SAFETY PRECAUTIONS for detail of stop type) when pressed.
- (2) DEADMAN switch: Functions are different depending on the teach pendant enable/disable switch setting status.
 - (a) **Enable:** Servo power is turned off and robot stops when the operator releases the DEADMAN switch or when the operator presses the switch strongly.
 - (b) **Disable:** The DEADMAN switch is disabled.

(Note) The DEADMAN switch is provided to stop the robot when the operator releases the teach pendant or presses the pendant strongly in case of emergency. The R-30iB Plus/R-30iB Mate Plus /R-30iB /R-30iB Mate/R-30iA/R-30iA Mate employs a 3-position DEADMAN switch, which allows the robot to operate when the 3-position DEADMAN switch is pressed to its intermediate point. When the operator releases the DEADMAN switch or presses the switch strongly, the robot stops immediately.

The operator's intention of starting teaching is determined by the controller through the dual operation of setting the teach pendant enable/disable switch to the enable position and pressing the DEADMAN switch. The operator should make sure that the robot could operate in such conditions and be responsible in carrying out tasks safely.

Based on the risk assessment by FANUC, number of operation of DEADMAN switch should not exceed about 10000 times per year.

The teach pendant, operator panel, and peripheral device interface send each robot start signal. However the validity of each signal changes as follows depending on the mode switch and the DEADMAN switch of the operator panel, the teach pendant enable switch and the remote condition on the software.

**For the R-30iB Plus/R-30iB Mate Plus/R-30iB/R-30iB Mate/R-30iA Controller
or CE or RIA specification of the R-30iA Mate Controller**

Mode	Teach pendant enable switch	Software remote condition	Teach pendant	Operator panel	Peripheral device
AUTO mode	On	Local	Not allowed	Not allowed	Not allowed
		Remote	Not allowed	Not allowed	Not allowed
	Off	Local	Not allowed	Allowed to start	Not allowed
		Remote	Not allowed	Not allowed	Allowed to start
T1, T2 mode	On	Local	Allowed to start	Not allowed	Not allowed
		Remote	Allowed to start	Not allowed	Not allowed
	Off	Local	Not allowed	Not allowed	Not allowed
		Remote	Not allowed	Not allowed	Not allowed

T1,T2 mode: DEADMAN switch is effective.

For the standard specification of R-30iA Mate Controller

Teach pendant enable switch	Software remote condition	Teach pendant	Peripheral device
On	Ignored	Allowed to start	Not allowed
Off	Local	Not allowed	Not allowed
	Remote	Not allowed	Allowed to start

- (6) (Only when R-30iB Plus/R-30iB Mate Plus/R-30iB/R-30iB Mate /R-30iA Controller or CE or RIA specification of R-30iA Mate controller is selected.) To start the system using the operator panel, make certain that nobody is in the robot operating space and that there are no abnormal conditions in the robot operating space.
- (7) When a program is completed, be sure to carry out the test operation according to the following procedure.
 - (a) Run the program for at least one operation cycle in the single step mode at low speed.
 - (b) Run the program for at least one operation cycle in the continuous operation mode at low speed.
 - (c) Run the program for one operation cycle in the continuous operation mode at the intermediate speed and check that no abnormalities occur due to a delay in timing.
 - (d) Run the program for one operation cycle in the continuous operation mode at the normal operating speed, and check that the system operates automatically without trouble.
 - (e) After checking the completeness of the program through the test operation above, execute it in the automatic operation mode.
- (8) While operating the system in the automatic operation mode, the teach pendant operator must leave the safety fence.

3.3 SAFETY OF THE MAINTENANCE ENGINEER

For the safety of maintenance engineer personnel, pay utmost attention to the following.

- (1) During operation, never enter the robot operating space.
- (2) A hazardous situation may arise when the robot or the system, are kept with their power-on during maintenance operations. Therefore, for any maintenance operation, the robot and the system should be put into the power-off state. If necessary, a lock should be in place in order to prevent any other person from turning on the robot and/or the system. In case maintenance needs to be executed in the power-on state, the emergency stop button must be pressed.
- (3) If it becomes necessary to enter the robot operating space while the power is on, press the emergency stop button on the operator box or operator panel, or the teach pendant before entering the range. The maintenance worker must indicate that maintenance work is in progress and be careful not to allow other people to operate the robot carelessly.
- (4) When entering the area enclosed by the safety fence, the worker must check the whole robot system in order to make sure no dangerous situations exist. In case the worker needs to enter the safety area whilst a dangerous situation exists, extreme care must be taken, and whole robot system status must be carefully monitored.
- (5) Before the maintenance of the pneumatic system is started, the supply pressure should be shut off and the pressure in the piping should be reduced to zero.
- (6) Before the start of maintenance work, check that the robot and its peripheral equipment are all in the normal operating condition.
- (7) Do not operate the robot in the automatic operation while anybody is in the robot operating space.
- (8) When you maintain the robot alongside a wall or instrument, or when multiple users are working nearby, make certain that their escape path is not obstructed.
- (9) When a tool is mounted on the robot, or when any movable device other than the robot is installed, such as belt conveyor, pay careful attention to its motion.
- (10) If necessary, have a user who is familiar with the robot system stand beside the operator panel and observe the work being performed. If any danger arises, the user should be ready to press the EMERGENCY STOP button at any time.
- (11) When replacing a part, please contact your local FANUC representative. If a wrong procedure is followed, an accident may occur, causing damage to the robot and injury to the user.
- (12) When replacing or reinstalling components, take care to prevent foreign material from entering the system.
- (13) When handling each unit or printed circuit board in the controller during inspection, turn off the circuit breaker to protect against electric shock.
If there are two cabinets, turn off the both circuit breaker.
- (14) A part should be replaced with a part recommended by FANUC. If other parts are used, malfunction or damage would occur. Especially, a fuse that is not recommended by FANUC should not be used. Such a fuse may cause a fire.
- (15) When restarting the robot system after completing maintenance work, make sure in advance that there is no person in the operating space and that the robot and the peripheral equipment are not abnormal.
- (16) When a motor or brake is removed, the robot arm should be supported with a crane or other equipment beforehand so that the arm would not fall during the removal.
- (17) Whenever grease is spilled on the floor, it should be removed as quickly as possible to prevent dangerous falls.
- (18) The following parts are heated. If a maintenance user needs to touch such a part in the heated state, the user should wear heat-resistant gloves or use other protective tools.
 - Servo motor
 - Inside the controller
 - Reducer
 - Gearbox
 - Wrist unit

- (19) Maintenance should be done under suitable light. Care must be taken that the light would not cause any danger.
- (20) When a motor, reducer, or other heavy load is handled, a crane or other equipment should be used to protect maintenance workers from excessive load. Otherwise, the maintenance workers would be severely injured.
- (21) The robot should not be stepped on or climbed up during maintenance. If it is attempted, the robot would be adversely affected. In addition, a misstep can cause injury to the worker.
- (22) When performing maintenance work in high place, secure a footstep and wear safety belt.
- (23) After the maintenance is completed, spilled oil or water and metal chips should be removed from the floor around the robot and within the safety fence.
- (24) When a part is replaced, all bolts and other related components should put back into their original places. A careful check must be given to ensure that no components are missing or left not mounted.
- (25) In case robot motion is required during maintenance, the following precautions should be taken :
 - Foresee an escape route. And during the maintenance motion itself, monitor continuously the whole robot system so that your escape route will not become blocked by the robot, or by peripheral equipment.
 - Always pay attention to potentially dangerous situations, and be prepared to press the emergency stop button whenever necessary.
- (26) The robot should be periodically inspected. (Refer to the robot mechanical manual and controller maintenance manual.) A failure to do the periodical inspection can adversely affect the performance or service life of the robot and may cause an accident
- (27) After a part is replaced, a test execution should be given for the robot according to a predetermined method. (See TESTING section of "Controller operator's manual".) During the test execution, the maintenance worker should work outside the safety fence.

4 SAFETY OF THE TOOLS AND PERIPHERAL EQUIPMENT

4.1 PRECAUTIONS IN PROGRAMMING

- (1) Use a limit switch or other sensor to detect a dangerous condition and, if necessary, design the program to stop the robot when the sensor signal is received.
- (2) Design the program to stop the robot when an abnormality occurs in any other robots or peripheral equipment, even though the robot itself is normal.
- (3) For a system in which the robot and its peripheral equipment are in synchronous motion, particular care must be taken in programming so that they do not interfere with each other.
- (4) Provide a suitable interface between the robot and its peripheral equipment so that the robot can detect the states of all devices in the system and can be stopped according to the states.

4.2 PRECAUTIONS FOR MECHANISM

- (1) Keep the component cells of the robot system clean, operate the robot where insulated from the influence of oil, water, and dust.
- (2) Don't use unconfirmed liquid for cutting fluid and cleaning fluid.
- (3) Adopt limit switches or mechanical stoppers to limit the robot motion, and avoid the robot from collisions against peripheral equipment or tools.
- (4) Observe the following precautions about the mechanical unit cables. Failure to follow precautions may cause problems.
 - Use mechanical unit cable that have required user interface.
 - Do not add user cable or hose to inside of the mechanical unit.
 - Please do not obstruct the movement of the mechanical unit when cables are added to outside of mechanical unit.
 - In the case of the model that a cable is exposed, please do not perform remodeling (Adding a protective cover and fix an outside cable more) obstructing the behavior of the outcrop of the cable.
 - When installing user peripheral equipment on the robot mechanical unit, please pay attention that the device does not interfere with the robot itself.
- (5) The frequent power-off stop for the robot during operation causes the trouble of the robot. Please avoid the system construction that power-off stop would be operated routinely. (Refer to bad case example.) Please perform power-off stop after reducing the speed of the robot and stopping it by hold stop or cycle stop when it is not urgent. (Please refer to "STOP TYPE OF ROBOT" in "SAFETY PRECAUTIONS" for detail of stop type.)

(Bad case example)

 - Whenever poor product is generated, a line stops by emergency stop and power-off of the robot is incurred.
 - When alteration is necessary, safety switch is operated by opening safety fence and power-off stop is incurred for the robot during operation.
 - An operator pushes the emergency stop button frequently, and a line stops.
 - An area sensor or a mat switch connected to safety signal operates routinely and power-off stop is incurred for the robot.
 - Power-off stop is regularly incurred due to an inappropriate setting for Dual Check Safety (DCS).
- (6) Power-off stop of Robot is executed when collision detection alarm (SRVO-050) etc. occurs. Please try to avoid unnecessary power-off stops. It may cause the trouble of the robot, too. So remove the causes of the alarm.

5 SAFETY OF THE ROBOT MECHANICAL UNIT

5.1 PRECAUTIONS IN OPERATION

- (1) When operating the robot in the jog mode, set it at an appropriate speed so that the operator can manage the robot in any eventuality.
- (2) Before pressing the jog key, be sure you know in advance what motion the robot will perform in the jog mode.

5.2 PRECAUTIONS IN PROGRAMMING

- (1) When the operating spaces of robots overlap, make certain that the motions of the robots do not interfere with each other.
- (2) Be sure to specify the predetermined work origin in a motion program for the robot and program the motion so that it starts from the origin and terminates at the origin. Make it possible for the operator to easily distinguish at a glance that the robot motion has terminated.

5.3 PRECAUTIONS FOR MECHANISMS

Keep the robot operation area clean, and operate the robot in an environment free of grease, water, and dust.

6 SAFETY OF THE END EFFECTOR

6.1 PRECAUTIONS IN PROGRAMMING

- (1) To control the pneumatic, hydraulic and electric actuators, carefully consider the necessary time delay after issuing each control command up to actual motion and ensure safe control.
- (2) Provide the end effector with a limit switch, and control the robot system by monitoring the state of the end effector.

7 STOP TYPE OF ROBOT (R-30iA, R-30iA Mate)

The following three robot stop types exist:

Power-Off Stop (Category 0 following IEC 60204-1)

Servo power is turned off and the robot stops immediately. Servo power is turned off when the robot is moving, and the motion path of the deceleration is uncontrolled.

The following processing is performed at Power-Off stop.

- An alarm is generated and servo power is turned off.
- The robot operation is stopped immediately. Execution of the program is paused.

Frequent Power-Off stop of the robot during operation can cause mechanical problems of the robot. Avoid system designs that require routine or frequent Power-Off stop conditions.

Controlled stop (Category 1 following IEC 60204-1)

The robot is decelerated until it stops, and servo power is turned off.

The following processing is performed at Controlled stop.

- The alarm "SRVO-199 Controlled stop" occurs along with a decelerated stop. Execution of the program is paused.
- An alarm is generated and servo power is turned off.

Hold (Category 2 following IEC 60204-1)

The robot is decelerated until it stops, and servo power remains on.

The following processing is performed at Hold.

- The robot operation is decelerated until it stops. Execution of the program is paused.

WARNING

- 1 The stopping distance and time of Controlled stop is longer than those of Power-Off stop. A risk assessment for the whole robot system which takes into consideration the increased stopping distance and stopping time is necessary when Controlled stop is used. Please refer to the operator's manual of a particular robot model for the data of stopping distance and time.
- 2 In multi arm system, the longest stopping distance and time of Controlled Stop among each robot are adopted as those for the system. A risk assessment for the whole robot system which takes into consideration a possibility that the stopping distance and time increase, is necessary on the multi arm system.
- 3 In the system which has extended axis, the longer stopping distance and time of Controlled Stop among robot and extended axis are adopted as those for the system. A risk assessment for the whole robot system which takes into consideration a possibility that the stopping distance and time increase, is necessary on the system which has extended axis. Please refer to the extended axis setup procedure of the controller operator's manual for considering the stopping distance and time of the extended axis.
- 4 In case of Controlled stop, motor power shutdown is delayed for a maximum of 2 seconds. In this case, a risk assessment for the whole robot system is necessary, including the 2 seconds delay.

When the emergency stop button is pressed or the FENCE is open, the stop type of robot is Power-Off stop or Controlled stop. The configuration of stop type for each situation is called *stop pattern*. The stop pattern is different according to the controller type or option configuration.

There are the following 3 Stop patterns.

Stop pattern	Mode	Emergency stop button	External Emergency stop	FENCE open	SVOFF input	Servo disconnect
A	AUTO	P-Stop	P-Stop	C-Stop	C-Stop	P-Stop
	T1	P-Stop	P-Stop	-	C-Stop	P-Stop
	T2	P-Stop	P-Stop	-	C-Stop	P-Stop
B	AUTO	P-Stop	P-Stop	P-Stop	P-Stop	P-Stop
	T1	P-Stop	P-Stop	-	P-Stop	P-Stop
	T2	P-Stop	P-Stop	-	P-Stop	P-Stop
C	AUTO	C-Stop	C-Stop	C-Stop	C-Stop	C-Stop
	T1	P-Stop	P-Stop	-	C-Stop	P-Stop
	T2	P-Stop	P-Stop	-	C-Stop	P-Stop

P-Stop: Power-Off stop

C-Stop: Controlled stop

-: Disable

The following table indicates the Stop pattern according to the controller type or option configuration.

Option	R-30iA				R-30iA Mate		
	Standard (Single)	Standard (Dual)	RIA type	CE type	Standard	RIA type	CE type
Standard	B (*)	A	A	A	A (**)	A	A
Stop type set (Stop pattern C) (A05B-2500-J570)	N/A	N/A	C	C	N/A	C	C

(*) R-30iA standard (single) does not have servo disconnect.

(**) R-30iA Mate Standard does not have servo disconnect, and the stop type of SVOFF input is Power-Off stop.

The stop pattern of the controller is displayed in "Stop pattern" line in software version screen. Please refer to "Software version" in operator's manual of controller for the detail of software version screen.

"Controlled stop by E-Stop" option

When "Stop type set (Stop pattern C) (A05B-2500-J570) option is specified, the stop type of the following alarms becomes Controlled stop but only in AUTO mode. In T1 or T2 mode, the stop type is Power-Off stop which is the normal operation of the system.

Alarm	Condition
SRVO-001 Operator panel E-stop	Operator panel emergency stop is pressed.
SRVO-002 Teach pendant E-stop	Teach pendant emergency stop is pressed.
SRVO-007 External emergency stops	External emergency stop input (EES1-EES11, EES2-EES21) is open. (R-30iA controller)
SRVO-194 Servo disconnect	Servo disconnect input (SD4-SD41, SD5-SD51) is open. (R-30iA controller)
SRVO-218 Ext.E-stop/Servo Disconnect	External emergency stop input (EES1-EES11, EES2-EES21) is open. (R-30iA Mate controller)
SRVO-408 DCS SSO Ext Emergency Stop	In DCS Safe I/O connect function, SSO[3] is OFF.
SRVO-409 DCS SSO Servo Disconnect	In DCS Safe I/O connect function, SSO[4] is OFF.

Controlled stop is different from Power-Off stop as follows:

- In Controlled stop, the robot is stopped on the program path. This function is effective for a system where the robot can interfere with other devices if it deviates from the program path.
- In Controlled stop, physical impact is less than Power-Off stop. This function is effective for systems where the physical impact to the mechanical unit or EOAT (End Of Arm Tool) should be minimized.
- The stopping distance and stopping time of Controlled stop is longer than the stopping distance and stopping time of Power-Off stop, depending on the robot model and axis. Please refer to the operator's manual of a particular robot model for the data of stopping distance and stopping time.

For the R-30iA or R-30iA Mate, this function is available only in CE or RIA type hardware.

When this option is loaded, this function cannot be disabled.

The stop type of DCS Position and Speed Check functions is not affected by the loading of this option.

 **WARNING**

The stopping distance and stopping time of Controlled stop are longer than the stopping distance and stopping time of Power-Off stop. A risk assessment for the whole robot system, which takes into consideration the increased stopping distance and stopping time, is necessary when this option is loaded.

8 STOP TYPE OF ROBOT (R-30iB, R-30iB Mate)

There are following four types of Stopping Robot.

Power-Off Stop (Category 0 following IEC 60204-1)

Servo power is turned off, and the robot stops immediately. Servo power is turned off when the robot is moving, and the motion path of the deceleration is uncontrolled.

“**Power-Off stop**” performs following processing.

- An alarm is generated, and then the servo power turns off. Instantly the robot stops.
- Execution of the program is paused.

Frequent Power-Off stop of the robot during operation can cause mechanical problems of the robot. Avoid system designs that require routine or frequent Power-Off stop conditions.

Controlled stop (Category 1 following IEC 60204-1)

The robot is decelerated until it stops, and servo power is turned off.

“**Controlled stop**” performs following processing.

- The alarm "SRVO-199 Controlled stop" occurs along with a decelerated stop. The program execution is paused.
- An alarm is generated, and then the servo power turns off.

Smooth stop (Category 1 following IEC 60204-1)

The robot is decelerated until it stops, and servo power is turned off.

“**Smooth stop**” performs following processing.

- The alarm "SRVO-289 Smooth Stop" occurs along with a decelerated stop. The program execution is paused.
- An alarm is generated, and then the servo power turns off.
- In Smooth stop, the robot decelerates until it stops with the deceleration time shorter than Controlled stop.

Hold (Category 2 following IEC 60204-1)

The robot is decelerated until it stops, and servo power remains on.

“**Hold**” performs following processing.

- The robot operation is decelerated until it stops. Execution of the program is paused.

⚠ WARNING

- 1 The stopping distance and time of Controlled stop and Smooth stop are longer than those of Power-Off stop. A risk assessment for the whole robot system which takes into consideration the increased stopping distance and stopping time is necessary when Controlled stop or Smooth Stop is used. Please refer to the operator's manual of a particular robot model for the data of stopping distance and time.
- 2 In multi arm system, the longest stopping distance and time of Controlled Stop or Smooth Stop among each robot are adopted as those for the system. A risk assessment for the whole robot system which takes into consideration a possibility that the stopping distance and time increase, is necessary on the multi arm system.
- 3 In the system which has extended axis, the longer stopping distance and time of Controlled Stop or Smooth Stop among robot and extended axis are adopted as those for the system. A risk assessment for the whole robot system which takes into consideration a possibility that the stopping distance and time increase, is necessary on the system which has extended axis. Please refer to the extended axis setup procedure of the controller operator's manual for considering the stopping distance and time of the extended axis.
- 4 When Smooth stop occurs during deceleration by Controlled stop, the stop type of robot is changed to Power-Off Stop.
When Smooth stop occurs during deceleration by Hold, the stop type of robot is changed to Power-Off Stop.
- 5 In case of Controlled stop or Smooth Stop, motor power shutdown is delayed for a maximum of 2 seconds. In this case, a risk assessment for the whole robot system is necessary, including the 2 seconds delay.

When the emergency stop button is pressed or the FENCE is open, the stop type of robot is Power-Off stop, Controlled stop, or Smooth stop. The configuration of stop type for each situation is called *stop pattern*. The stop pattern is different according to the option configuration.

There are the following 3 Stop patterns.

Stop pattern	Mode	Emergency stop button	External Emergency stop	FENCE open	SVOFF input	Deadman switch (*)
A	AUTO	P-Stop	P-Stop	C-Stop	C-Stop	-
	T1	P-Stop	P-Stop	-	C-Stop	P-Stop
	T2	P-Stop	P-Stop	-	C-Stop	P-Stop
C	AUTO	C-Stop	C-Stop	C-Stop	C-Stop	-
	T1	P-Stop	P-Stop	-	C-Stop	P-Stop
	T2	P-Stop	P-Stop	-	C-Stop	P-Stop
D	AUTO	S-Stop	S-Stop	C-Stop	C-Stop	-
	T1	S-Stop	S-Stop	-	C-Stop	S-Stop
	T2	S-Stop	S-Stop	-	C-Stop	S-Stop

P-Stop: Power-Off stop

C-Stop: Controlled stop

S-Stop: Smooth stop

-: Disable

(*) The stop pattern of NTED input is same as Deadman switch.

The following table indicates the Stop pattern according to the controller type or option configuration.

Option	R-30iB/ R-30iB Mate
Standard	A(**)
Controlled stop by E-Stop (A05B-2600-J570)	C(**)
Smooth E-Stop (A05B-2600-J651)	D(**)

(**) R-30iB Mate does not have SVOFF input.

The stop pattern of the controller is displayed in "Stop pattern" line in software version screen. Please refer to "Software version" in operator's manual of controller for the detail of software version screen.

"Controlled stop by E-Stop" option

When "Controlled stop by E-Stop" (A05B-2600-J570) option is specified, the stop type of the following alarms become Controlled stop but only in AUTO mode. In T1 or T2 mode, the stop type is Power-Off stop which is the normal operation of the system.

Alarm	Condition
SRVO-001 Operator panel E-stop	Operator panel emergency stop is pressed.
SRVO-002 Teach pendant E-stop	Teach pendant emergency stop is pressed.
SRVO-007 External emergency stops	External emergency stop input (EES1-EES11, EES2-EES21) is open.
SRVO-408 DCS SSO Ext Emergency Stop	In DCS Safe I/O connect function, SSO[3] is OFF.
SRVO-409 DCS SSO Servo Disconnect	In DCS Safe I/O connect function, SSO[4] is OFF.

Controlled stop is different from **Power-Off stop** as follows:

- In Controlled stop, the robot is stopped on the program path. This function is effective for a system where the robot can interfere with other devices if it deviates from the program path.
- In Controlled stop, physical impact is less than Power-Off stop. This function is effective for systems where the physical impact to the mechanical unit or EOAT (End Of Arm Tool) should be minimized.
- The stopping distance and time of Controlled stop is longer than those of Power-Off stop, depending on the robot model and axis.

When this option is loaded, this function cannot be disabled.

The stop type of DCS Position and Speed Check functions is not affected by the loading of this option.

WARNING

The stopping distance and time of Controlled stop are longer than those of Power-Off stop. A risk assessment for the whole robot system which takes into consideration the increased stopping distance and stopping time, is necessary when this option is loaded.

"Smooth E-Stop Function" option

When "**Smooth E-Stop Function**" (A05B-2600-J651) option is specified, the stop type of the following alarms becomes Smooth stop in all operation modes (AUTO, T1 and T2 mode).

Alarm	Condition
SRVO-001 Operator panel E-stop	Operator panel emergency stop is pressed.
SRVO-002 Teach pendant E-stop	Teach pendant emergency stop is pressed.
SRVO-003 Deadman switch released	Both deadman switches on Teach pendant are released.
SRVO-007 External emergency stops	External emergency stop input (EES1-EES11, EES2-EES21) is open.
SRVO-037 IMSTP input (Group: %d)	IMSTP input (*IMSTP signal for a peripheral device interface) is OFF.
SRVO-232 NTED input	NTED input (NTED1-NTED11, NTED2-NTED21) is open.
SRVO-408 DCS SSO Ext Emergency Stop	In DCS Safe I/O connect function, SSO[3] is OFF.
SRVO-409 DCS SSO Servo Disconnect	In DCS Safe I/O connect function, SSO[4] is OFF.
SRVO-410 DCS SSO NTED input	In DCS Safe I/O connect function, SSO[5] is OFF.
SRVO-419 DCS PROFIsafe comm. error	PROFINET Safety communication error occurs.

Smooth stop is different from **Power-Off stop** as follows:

- In Smooth stop, the robot is stopped along the program path. This function is effective for a system where the robot can interfere with other devices if it deviates from the program path.
- In Smooth stop, physical impact is less than Power-Off stop. This function is effective for systems where the physical impact to the mechanical unit or EOAT (End Of Arm Tool) should be minimized.
- The stopping distance and time of Smooth stop is longer than those of Power-Off stop, depending on the robot model and axis.

Smooth stop is different from **Controlled stop** as follows:

- The stopping distance and time of Smooth stop is normally shorter than those of Controlled stop, depending on the robot model and axis.

When this option is loaded, this function cannot be disabled.

The stop type of DCS Position and Speed Check functions is not affected by the loading of this option.

WARNING

The stopping distance and time of Smooth stop are longer than those of Power-Off stop. A risk assessment for the whole robot system which takes into consideration the increased stopping distance and stopping time, is necessary when this option is loaded.

9 STOP TYPE OF ROBOT (R-30iB Plus, R-30iB Mate Plus)

There are following three types of Stop Category.

Stop Category 0 following IEC 60204-1 (Power-off Stop)

Servo power is turned off, and the robot stops immediately. Servo power is turned off when the robot is moving, and the motion path of the deceleration is uncontrolled.

“Stop Category 0” performs following processing.

- An alarm is generated, and then the servo power turns off. Instantly the robot stops.
- Execution of the program is paused.

Frequent Category 0 Stop of the robot during operation can cause mechanical problems of the robot. Avoid system designs that require routine or frequent Category 0 Stop conditions.

Stop Category 1 following IEC 60204-1 (Controlled Stop, Smooth Stop)

The robot is decelerated until it stops, and servo power is turned off.

“Stop Category 1” performs following processing.

- The alarm "SRVO-199 Controlled stop" or "SRVO-289 Smooth Stop" occurs along with a decelerated stop. The program execution is paused.
- An alarm is generated, and then the servo power turns off.

In Smooth stop, the robot decelerates until it stops with the deceleration time shorter than Controlled stop. The stop type of Stop Category 1 is different according to the robot model or option configuration. Please refer to the operator's manual of a particular robot model.

Stop Category 2 following IEC 60204-1 (Hold)

The robot is decelerated until it stops, and servo power remains on.

“Stop Category 2” performs following processing.

- The robot operation is decelerated until it stops. Execution of the program is paused.

WARNING

- 1 The stopping distance and time of Stop Category 1 are longer than those of Stop Category 0. A risk assessment for the whole robot system which takes into consideration the increased stopping distance and stopping time is necessary when Stop Category 1 is used. Please refer to the operator's manual of a particular robot model for the data of stopping distance and time.
- 2 In multi arm system, the longest stopping distance and time of Stop Category 1 among each robot are adopted as those for the system. A risk assessment for the whole robot system which takes into consideration a possibility that the stopping distance and time increase, is necessary on the multi arm system.
- 3 In the system which has extended axis, the longer stopping distance and time of Stop Category 1 among robot and extended axis are adopted as those for the system. A risk assessment for the whole robot system which takes into consideration a possibility that the stopping distance and time increase, is necessary on the system which has extended axis. Please refer to the extended axis setup procedure of the controller operator's manual for considering the stopping distance and time of the extended axis.
- 4 When Stop Category 1 occurs during deceleration by Stop Category 2, the stop type of robot is changed to Stop Category 0.
- 5 In case of Stop Category 1, motor power shutdown is delayed for a maximum of 2 seconds. In this case, a risk assessment for the whole robot system is necessary, including the 2 seconds delay.

When the emergency stop button is pressed or the FENCE is open, the stop type of robot is Stop Category 0 or Stop Category 1. The configuration of stop type for each situation is called *stop pattern*. The stop pattern is different according to the option configuration.

There are the following 3 Stop patterns.

Stop pattern	Mode	Emergency stop button	External Emergency stop	FENCE open	SVOFF input	Deadman switch (*)
A	AUTO	Category 0	Category 0	Category 1	Category 1	-
	T1	Category 0	Category 0	-	Category 1	Category 0
	T2	Category 0	Category 0	-	Category 1	Category 0
C	AUTO	Category 1	Category 1	Category 1	Category 1	-
	T1	Category 0	Category 0	-	Category 1	Category 0
	T2	Category 0	Category 0	-	Category 1	Category 0
D	AUTO	Category 1	Category 1	Category 1	Category 1	-
	T1	Category 1	Category 1	-	Category 1	Category 1
	T2	Category 1	Category 1	-	Category 1	Category 1

Category 0: Stop Category 0

Category 1: Stop Category 1

-: Disable

(*) The stop pattern of NTED input is same as Deadman switch.

The following table indicates the Stop pattern according to the controller type or option configuration. The case R651 is specified.

Option	R-30iB Plus/ R-30iB Mate Plus
Standard	C(**)
Old Stop Function (A05B-2670-J680)	A(**)
All Smooth Stop Function (A05B-2670-J651)	D(**)

The case R650 is specified.

Option	R-30iB Plus/ R-30iB Mate Plus
Standard	A(**)
Stop Category 1 by E-Stop (A05B-2670-J521)	C(**)
All Smooth Stop Function (A05B-2670-J651)	D(**)

(**) R-30iB Mate Plus does not have SVOFF input.

The stop pattern of the controller is displayed in "Stop pattern" line in software version screen. Please refer to "Software version" in operator's manual of controller for the detail of software version screen.

"Old Stop Function" option

When "Old Stop Function" (A05B-2670-J680) option is specified, the stop type of the following alarms becomes Stop Category 0 in AUTO mode.

Alarm	Condition
SRVO-001 Operator panel E-stop	Operator panel emergency stop is pressed.
SRVO-002 Teach pendant E-stop	Teach pendant emergency stop is pressed.
SRVO-007 External emergency stops	External emergency stop input (EES1-EES11, EES2-EES21) is open.
SRVO-408 DCS SSO Ext Emergency Stop	In DCS Safe I/O connect function, SSO[3] is OFF.
SRVO-409 DCS SSO Servo Disconnect	In DCS Safe I/O connect function, SSO[4] is OFF.

Stop Category 0 is different from **Stop Category 1** as follows:

- In Stop Category 0, servo power is turned off, and the robot stops immediately. Servo power is turned off when the robot is moving, and the motion path of the deceleration is uncontrolled.
- The stopping distance and time of Stop Category 0 is shorter than those of Stop Category 1, depending on the robot model and axis.

When this option is loaded, this function cannot be disabled.

The stop type of DCS Position and Speed Check functions is not affected by the loading of this option.

"All Smooth Stop Function" option

When "All Smooth Stop Function" (A05B-2670-J651) option is specified, the stop type of the following alarms becomes Stop Category 1 in all operation modes (AUTO, T1 and T2 mode).

Alarm	Condition
SRVO-001 Operator panel E-stop	Operator panel emergency stop is pressed.
SRVO-002 Teach pendant E-stop	Teach pendant emergency stop is pressed.
SRVO-003 Deadman switch released	Both deadman switches on Teach pendant are released.
SRVO-007 External emergency stops	External emergency stop input (EES1-EES11, EES2-EES21) is open.
SRVO-037 IMSTP input (Group: %d)	IMSTP input (*IMSTP signal for a peripheral device interface) is ON.
SRVO-232 NTED input	NTED input (NTED1-NTED11, NTED2-NTED21) is open.
SRVO-408 DCS SSO Ext Emergency Stop	In DCS Safe I/O connect function, SSO[3] is OFF.
SRVO-409 DCS SSO Servo Disconnect	In DCS Safe I/O connect function, SSO[4] is OFF.
SRVO-410 DCS SSO Ext Emergency Stop	In DCS Safe I/O connect function, SSO[5] is OFF.
SRVO-419 DCS PROFIsafe comm. error	PROFINET Safety communication error occurs.

Stop Category 1 is different from **Stop Category 0** as follows:

- In Stop Category 1, the robot is stopped along the program path. This function is effective for a system where the robot can interfere with other devices if it deviates from the program path.
- In Stop Category 1, physical impact is less than Stop Category 0. This function is effective for systems where the physical impact to the mechanical unit or EOAT (End of Arm Tool) should be minimized.
- The stopping distance and time of Stop Category 1 is longer than those of Stop Category 0, depending on the robot model and axis.

When this option is loaded, this function cannot be disabled.

The stop type of DCS Position and Speed Check functions is not affected by the loading of this option.



WARNING

The stopping distance and time of Stop Category 1 are longer than those of Stop Category 0. A risk assessment for the whole robot system which takes into consideration the increased stopping distance and stopping time, is necessary when this option is loaded.

"Stop Category 1 by E-Stop" option

When "Stop Category 1 by E-Stop" (A05B-2670-J521) option is specified, the stop type of the following alarms become Category 1 Stop but only in AUTO mode. In T1 or T2 mode, the stop type is Category 0 Stop which is the normal operation of the system.

Alarm	Condition
SRVO-001 Operator panel E-stop	Operator panel emergency stop is pressed.
SRVO-002 Teach pendant E-stop	Teach pendant emergency stop is pressed.
SRVO-007 External emergency stops	External emergency stop input (EES1-EES11, EES2-EES21) is open.
SRVO-408 DCS SSO Ext Emergency Stop	In DCS Safe I/O connect function, SSO[3] is OFF.
SRVO-409 DCS SSO Servo Disconnect	In DCS Safe I/O connect function, SSO[4] is OFF.

Stop Category 1 is different from **Stop Category 0** as follows:

- In Stop Category 1, the robot is stopped along the program path. This function is effective for a system where the robot can interfere with other devices if it deviates from the program path.
- In Stop Category 1, physical impact is less than Stop Category 0. This function is effective for systems where the physical impact to the mechanical unit or EOAT (End of Arm Tool) should be minimized.
- The stopping distance and time of Stop Category 1 is longer than those of Stop Category 0, depending on the robot model and axis.

When this option is loaded, this function cannot be disabled.

The stop type of DCS Position and Speed Check functions is not affected by the loading of this option.

WARNING

The stopping distance and time of Stop Category 1 are longer than those of Stop Category 0. A risk assessment for the whole robot system which takes into consideration the increased stopping distance and stopping time, is necessary when this option is loaded.

10 WARNING LABEL

(1) Greasing and degreasing label

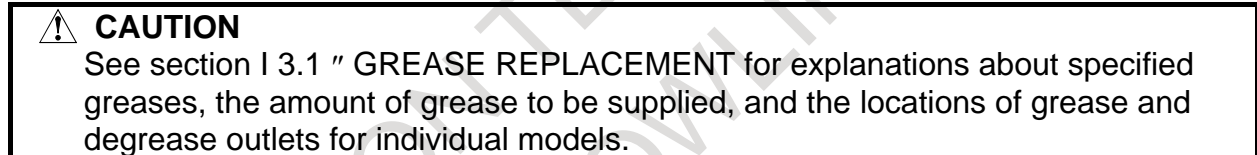

Fig. 10 (a) Greasing and Degreasing Label

Description

When greasing and degreasing, observe the instructions indicated on this label.

- 1) When greasing, be sure to keep the grease outlet open.
- 2) Use a manual pump to grease.
- 3) Be sure to use a specified grease.



(2) Step-on prohibitive label



Fig. 10 (b) Step-on Prohibitive Label

Description

Do not step on or climb the robot or controller as it may adversely affect the robot and positioner and you may get hurt if you lose your footing as well.

(3) High-temperature warning label

Fig. 10 (c) High-temperature warning label

Description

Be cautious about a section where this label is affixed, as the section generates heat. If you have to inevitably touch such a section when it is hot, use a protective provision such as heat-resistant gloves.

(4) Transportation label

Fig. 10 (d) Transportation label (300kg payload (Hollow type)), (300kg/500kg payload (Hollow type))

Description

When transporting the positioner, observe the instruction on the transportation label. The above label includes the following instructions.

Using a crane

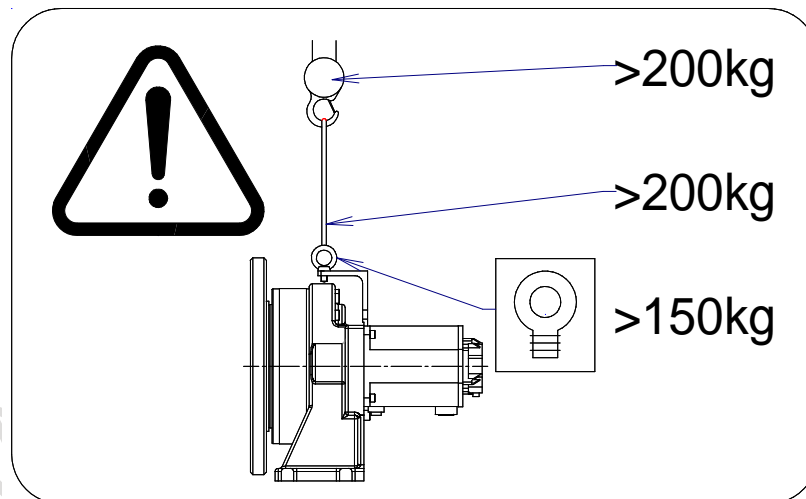
- Use a crane having a load capacity of 200 kg or greater.
- Use one sling having a load capacity of 200 kg or greater.
- Use two eyebolts with an allowable load of 1470 N (150 kgf) or greater. (The eyebolts are attached during shipment.)

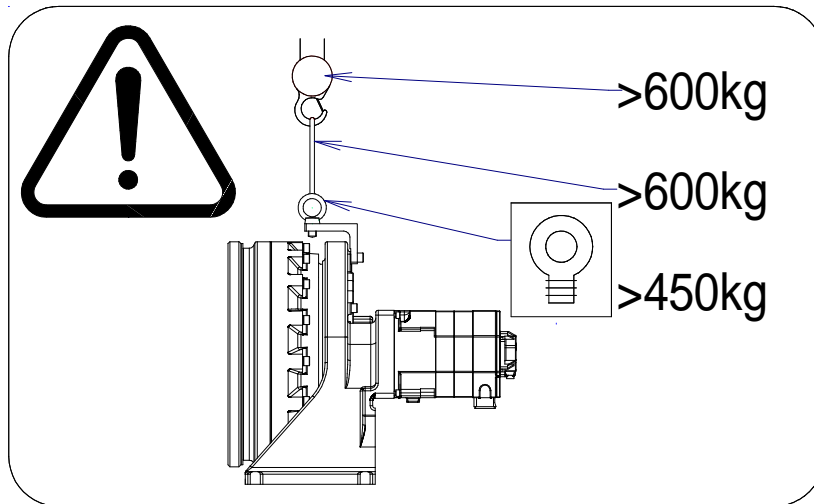

Fig. 10 (e) Transportation label (1000kg/1500kg payload (Hollow type))

Description

When transporting the positioner, observe the instruction on the transportation label. The above label includes the following instructions.

Using a crane

- Use a crane having a load capacity of 600 kg or greater.
- Use one sling having a load capacity of 600 kg or greater.
- Use two eyebolts with a allowable load of 4410 N (450 kgf) or greater. (The eyebolts are attached during shipment.)

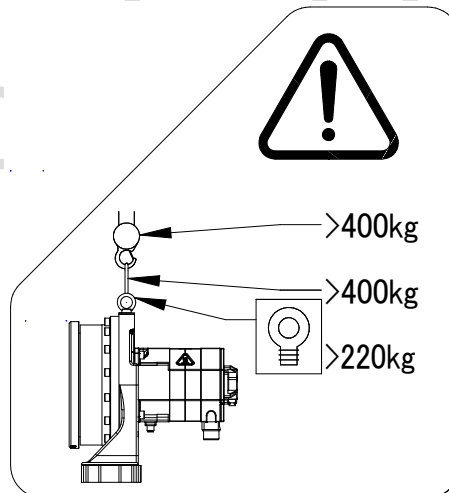

Fig. 10 (f) Transportation label (1000kg/1500kg payload (Compact type))

Description

When transporting the positioner, observe the instruction on the transportation label. The above label includes the following instructions.

Using a crane

- Use a crane having a load capacity of 400 kg or greater.
- Use one sling having a load capacity of 400 kg or greater.
- Use two eyebolts with a allowable load of 2156 N (220 kgf) or greater. (The eyebolts are attached during shipment.)

(5) **High current attention label**
(Infinite continuous turn mechanical option)



Fig. 10 (g) High current attention Label

Description

Do not access during energized high current inside.

170616

JR AUTOMATION TECHNOLOGIES INC*
JDOWLING

PREFACE

This manual describes maintenance and connection work for the servo positioner. Before replacing parts, check the specifications of the mechanical unit.

Model name	Mechanical unit specification No.	Remarks
1-Axis Servo Positioner	A05B-1220-J101	300kg payload (Hollow type)
1-Axis Servo Positioner	A05B-1220-J102	1000kg/1500kg payload (Hollow type)
1-Axis Servo Positioner	A05B-1220-J103	300kg/500kg payload (Hollow type)
1-Axis Servo Positioner	A05B-1220-J104	1000kg/1500kg payload (Compact type)

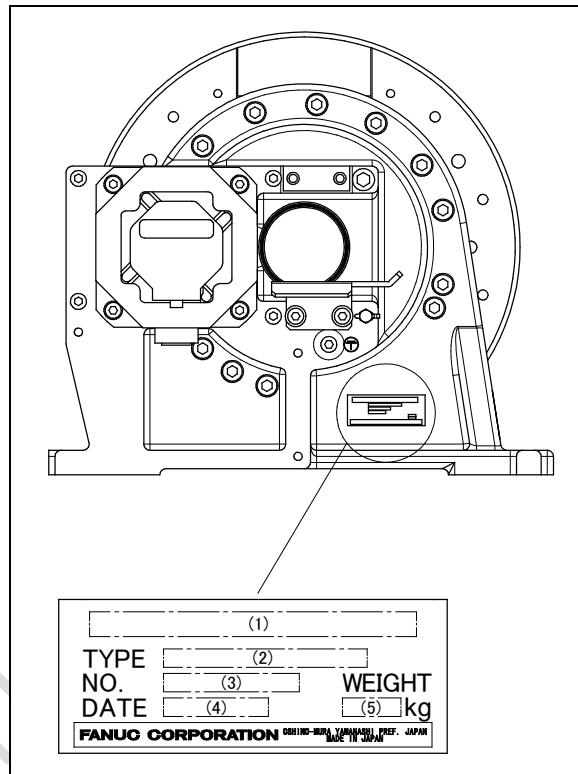

Position of label indicating mechanical unit specification number

No.	(1)	(2)	(3)	(4)	(5)
CONTENTS	MODEL	TYPE	No.	DATE	WEIGHT kg
LETTERS	1-Axis Servo Positioner	A05B-1220-J101	SERIAL NO. IS PRINTED	PRODUCTION YEAR AND MONTH ARE PRINTED	85
	1-Axis Servo Positioner	A05B-1220-J102			280
	1-Axis Servo Positioner	A05B-1220-J103			85
	1-Axis Servo Positioner	A05B-1220-J104			130

NOTE

The following abbreviations are used herein.

300kg payload (Hollow type)

: 300kg payload 1-axis servo positioner (Hollow type)

300kg/500kg payload (Hollow type)

: 300kg/500kg payload 1-axis servo positioner (Hollow type)

1000kg/1500kg payload (Hollow type)

: 1000kg/1500kg payload 1-axis servo positioner (Hollow type)

1000kg/1500kg payload (Compact type)

: 1000kg/1500kg payload 1-axis servo positioner (Compact type)

Specification (1/3)

Item	Specifications
Model	300kg payload 1-axis servo positioner (Hollow type)
Installation	Floor, Wall mount (*1), Upside-down
Motion range	740° (-370° - +370°) 12.9 rad (-6.46 rad - +6.46 rad) Continuous rotation is available.
Maximum operation speed (*2)	160°/sec 2.79 rad/sec
Max. load capacity (*3)	300 kg
Allowable load moment	36 kgf·m 353 N·m
Allowable bending moment	250 kgf·m 2450 N·m
Allowable load inertia	2350 kgf·cm·s ² 230 kg·m ²
Repeatability	±0.05mm (R=500)
Drive method	Electric servo drive by AC servo motor
Weight	About 85 kg
Follower unit (option) weight (*4)	About 47 kg-(Follower unit (insulated flange)) About 16 kg-(Follower unit (non-insulated flange))
Installation environment	Ambient temperature : 0 - 45°C Ambient humidity (*5) Normally : 75%RH or less Short time 95%RH or less (within 1 month) (No dew or frost allowed) Vibration acceleration : 4.9m/s ² (0.5G) or less Free of corrosive gases (*6)

- (*1) Refer to Fig. 3.3 (j) of CONNECTION for the wall mount.
- (*2) During short distance motions, the axis speed may not reach the maximum value stated.
- (*3) 300kg payload 1-axis servo positioner (Hollow type) does not support 500kg. Refer to Section 2.2 of CONNECTION about changing method of payload specifications.
- (*4) Two follower units (A05B-1220-J151, A05B-1220-J152) are prepared as option.
- (*5) When robot is used in low temperature environment that is near to 0°C, or robot is not operated for a long time in the environment that is less than 0°C in a holiday or the night, because viscous resistance of the drive train is so big that may cause occurrence of collision detect alarm (SRVO-050) etc. In this case, we recommend performing the warm up operation for several minutes.
- (*6) Contact the service representative, if the robot is to be used in an environment or a place subjected to hot/cold temperatures, severe vibrations, heavy dust, cutting oil splash and or other foreign substances.

Specification (2/3)

Item	Specifications	
Model	300kg/500kg payload 1-axis servo positioner (Hollow type)	
Installation	Floor, Wall mount (*1), Upside-down	
Motion range	740° (-370° - +370°) 12.9 rad (-6.46 rad - +6.46 rad) Continuous rotation is available. (There is the Infinite continuous turn mechanical option) (*2)	
Maximum operation speed (*3)	160°/sec 2.79 rad/sec	130°/sec 2.27 rad/sec
Max. load capacity (*4)	300 kg	500 kg
Allowable load moment	36 kgf·m 353 N·m	60 kgf·m 588 N·m
Allowable bending moment	400 kgf·m 3920 N·m	
Allowable load inertia	2350 kgf·cm·s ² 230 kg·m ²	3673 kgf·cm·s ² 360 kg·m ²
Repeatability	±0.05mm (R=500)	
Drive method	Electric servo drive by AC servo motor	
Weight	About 88 kg	
Follower unit (option) weight (*5)	About 47 kg-(Follower unit (insulated flange)) About 16 kg-(Follower unit (non-insulated flange))	
Installation environment	Ambient temperature : 0 - 45°C Ambient humidity (*6) Normally : 75%RH or less Short time 95%RH or less (within 1 month) (No dew or frost allowed) Vibration acceleration : 4.9m/s ² (0.5G) or less Free of corrosive gases (*7)	

(*1) Refer to Fig. 3.3 (j) of CONNECTION for the wall mount.

(*2) Infinite continuous turn mechanical option specification : A05B-1220-J117

(*3) During short distance motions, the axis speed may not reach the maximum value stated.

(*4) Mechanical software differs depend on the payload specification when the positioner is shipped. Refer to Section 2.2 of CONNECTION about changing method of payload specifications.

300kg payload : A05B-2500-H879

500kg payload : A05B-2500-H875

(*5) Two follower units (A05B-1220-J151, A05B-1220-J152) are prepared as option.

(*6) When robot is used in low temperature environment that is near to 0°C, or robot is not operated for a long time in the environment that is less than 0°C in a holiday or the night, because viscous resistance of the drive train is so big that may cause occurrence of collision detect alarm (SRVO-050) etc. In this case, we recommend performing the warm up operation for several minutes.

(*7) Contact the service representative, if the robot is to be used in an environment or a place subjected to hot/cold temperatures, severe vibrations, heavy dust, cutting oil splash and or other foreign substances.

Specification (3/3)

Item	Specifications	
Model	1000kg/1500kg payload 1-axis servo positioner (Hollow type) 1000kg/1500kg payload 1-axis servo positioner (Compact type)	
Installation	Floor, Wall mount (*1), Upside-down	
Motion range	740° (-370° - +370°) 12.9 rad (-6.45 rad - +6.45 rad) Continuous rotation is available.	
Maximum operation speed (*2)	120°/sec 2.09 rad/sec	90°/sec 1.57 rad/sec
Max. load capacity (*3)	1000 kg	1500 kg
Allowable load moment	160 kgf·m 1568 N·m	200 kgf·m 1960 N·m
Allowable bending moment	2100 kgf·m 20580 N·m (*4)	2100 kgf·m 20580 N·m (*4)
	720 kgf·m 7056 N·m (*5)	720 kgf·m 7056 N·m (*5)
Allowable load inertia	4,700 kgf·cm·s ² 460 kg·m ²	7000 kgf·cm·s ² 686 kg·m ²
Repeatability	±0.05mm (R=500)	
Drive method	Electric servo drive by AC servo motor	
Weight	About 280 kg (1000kg/1500kg payload (Hollow type))	
	About 130 kg (1000kg/1500kg payload (Compact type))	
Follower unit (option) weight (*6)	About 47 kg-(Follower unit (insulated flange))	
	About 16 kg-(Follower unit (non-insulated flange))	
Installation environment	Ambient temperature 0 - 45°C Ambient humidity (*7)	
	Normally : 75%RH or less	
	Short time 95%RH or less (within 1 month) (No dew or frost allowed)	
	Vibration acceleration : 4.9m/s ² (0.5G) or less	
	Free of corrosive gases (*8)	

- (*1) Refer to Fig. 3.3 (j) of CONNECTION for the wall mount.
- (*2) During short distance motions, the axis speed may not reach the maximum value stated.
- (*3) Mechanical software differs depend on the payload specification when the positioner is shipped. Refer to Section 2.2 of CONNECTION about changing method of payload specifications.
 1000kg payload (Hollow type) : A05B-2500-H880
 1500kg payload (Hollow type) : A05B-2500-H876
 1000kg payload (Compact type) : A05B-2500-H877
 1500kg payload (Compact type) : A05B-2500-H878
- (*4) 1000kg/1500kg payload 1-axis servo positioner (Hollow type)
- (*5) 1000kg/1500kg payload 1-axis servo positioner (Compact type)
- (*6) Two follower units (A05B-1220-J151, A05B-1220-J152) are prepared as option.
- (*7) When robot is used in low temperature environment that is near to 0°C, or robot is not operated for a long time in the environment that is less than 0°C in a holiday or the night, because viscous resistance of the drive train is so big that may cause occurrence of collision detect alarm (SRVO-050) etc. In this case, we recommend performing the warm up operation for several minutes.
- (*8) Contact the service representative, if the robot is to be used in an environment or a place subjected to hot/cold temperatures, severe vibrations, heavy dust, cutting oil splash and or other foreign substances.

Dust-proof/drip performance

	Normal specification
MECHANICAL UNIT	IP54

NOTE

Definition of IP 54

5= Dust-tight: Ingress of dust is not entirely prevented, but it must not enter in sufficient quantity to interfere with the satisfactory of the equipment.

4= Protection from water immersion : Water splashing against the enclosure from any direction shall have no harmful effect.

Performance of resistant chemicals and resistant solvents

- (1) The positioner (including severe dust/liquid protection model) cannot be used with the following liquids. Potentially these liquids will cause irreversible damage to the rubber parts (such as: gaskets, oil seals, O-rings etc.). (As exception to this only liquids tested and approved by FANUC can be used with the robot.)
 - (a) Organic solvents
 - (b) Coolant including chlorine / gasoline
 - (c) Amine type detergent
 - (d) Acid, alkali and liquid causing rust
 - (e) Other liquids or solutions, that will harm NBR
- (2) When the positioner work in the environment, using water or liquid, complete draining of J1 base must be done. Incomplete draining of J1 base will make the positioner break down.
- (3) Don not use unconfirmed liquid.
- (4) Do not use the positioner immersed in water, neither temporary nor permanent. Positioner must not be wet permanently.

*Example : in case motor surface is exposed to water for a long time, liquid may invade inside the motor and cause failure.

RELATED MANUALS

For the FANUC Robot series, the following manuals are available:

Safety handbook B-80687EN All persons who use the FANUC Robot and system designer must read and understand thoroughly this handbook		Intended readers: Operator, system designer Topics: Safety items for robot system design, operation, maintenance
R-J3iB Mate controller	Setup and Operations manual LR ARC TOOL B-82094EN LR HANDLING TOOL B-81524EN	Intended readers: Operator, programmer, maintenance engineer, system designer Topics: Robot functions, operations, programming, setup, interfaces, alarms Use: Robot operation, teaching, system design
	Maintenance manual B-81525EN B-81525EN-1 (For Europe)	Intended readers : Maintenance engineer, system designer Topics : Installation : start-up, connection, maintenance Use : Installation, start-up, connection, maintenance
R-J3iB controller	Setup and Operations manual SPOT TOOL B-81464EN-1 HANDLING TOOL B-81464EN-2 ARC TOOL B-81464EN-3	Intended readers: Operator, programmer, maintenance engineer, system designer Topics: Robot functions, operations, programming, setup, interfaces, alarms Use: Robot operation, teaching, system design
	Maintenance manual B-81465EN B-81465EN-1 (For Europe)	Intended readers : Maintenance engineer, system designer Topics : Installation : start-up, connection, maintenance Use : Installation, start-up, connection, maintenance
R-30iA Mate controller	Operator's Manual LR HANDLING TOOL B-83134EN-1 LR ARC TOOL B-83134EN-2 ALARM CODE LIST B-83124EN-6	Intended readers: Operator, programmer, maintenance engineer, system designer Topics: Robot functions, operations, programming, setup, interfaces, alarms Use: Robot operation, teaching, system design
	Maintenance Manual B-82725EN B-82725EN-1 (For Europe) B-82725EN-2 (For RIA)	Intended readers : Maintenance engineer, system designer Topics : Installation : start-up, connection, maintenance Use : Installation, start-up, connection, maintenance

R-30iA controller	Setup and Operations manual SPOT TOOL+ B-83124EN-1 HANDLING TOOL B-83124EN-2 ARC TOOL B-83124EN-3 DISPENSE TOOL B-83124EN-4 ALARM CODE LIST B-83124EN-6	Intended readers: Operator, programmer, maintenance engineer, system designer Topics: Robot functions, operations, programming, setup, interfaces, alarms Use: Robot operation, teaching, system design
	Maintenance manual B-82595EN B-82595EN-1 (For Europe) B-82595EN-2 (For RIA)	Intended readers : Maintenance engineer, system designer Topics : Installation : start-up, connection, maintenance Use : Installation, start-up, connection, maintenance
R-30iB/ R-30iB Mate/ R-30iB Plus/ R-30iB Mate Plus controller	OPERATOR'S MANUAL (Basic Operation) B-83284EN OPERATOR'S MANUAL (Alarm Code List) B-83284EN-1 OPERATOR'S MANUAL (Optional Function) B-83284EN-2 ARC Welding Function OPERATOR'S MANUAL B-83284EN-3 Spot Welding Function OPERATOR'S MANUAL B-83284EN-4 Dispense Function OPERATOR'S MANUAL B-83284EN-5	Intended readers: Operator, programmer, maintenance engineer, system designer Topics: Robot functions, operations, programming, setup, interfaces, alarms Use: Robot operation, teaching, system design
	MAINTENANCE MANUAL R-30iB, R-30iB Plus : B-83195EN R-30iB Mate, R-30iB Mate Plus: B-83525EN	Intended readers : Maintenance engineer, system designer Topics : Installation : start-up, connection, maintenance Use : Installation, start-up, connection, maintenance
Robot mechanical unit	For the robot mechanical unit, refer to the manual of each robot.	

This manual uses following terms.

Name	Terms in this manual
Connection cable between robot and controller	Robot connection cable
Robot mechanical unit	Mechanical unit

JR AUTOMATION TECHNOLOGIES INC*
JDOWLING

TABLE OF CONTENTS

SAFETY PRECAUTIONS	s-1
PREFACE	p-1
I. MAINTENANCE	
1 CONFIGURATION	3
2 CHECKS AND MAINTENANCE	4
2.1 PERIODIC MAINTENANCE	4
2.1.1 Daily Checks	4
2.1.2 Periodic Check and Maintenance	5
2.2 CHECK POINTS	7
2.2.1 Supply conductive grease, check the abrasion of the ground brush (for 300kg/500kg payload (Hollow type) Infinite continuous turn mechanical option)	7
2.2.2 Confirmation of Oil Seepage	9
2.2.3 Confirmation of the Air Control Set	10
2.3 MAINTENANCE TOOLS	11
3 PERIODIC MAINTENANCE	12
3.1 GREASE REPLACEMENT	12
3.2 PROCEDURE FOR RELEASING THE GREASE REMAINING PRESSURE	14
3.3 BATTERY REPLACEMENT	15
3.4 GREASING (for 300kg/500kg payload (Hollow type) Infinite continuous turn mechanical option)	17
4 TROUBLESHOOTING	18
4.1 TROUBLESHOOTING	18
4.2 BACKLASH MEASUREMENT	25
4.3 COMPONENT REPLACEMENT AND ADJUSTMENT ITEMS	26
5 ADJUSTMENTS	27
5.1 REFERENCE POSITION AND MOVING RANGE	27
5.2 MASTERING	28
5.2.1 Resetting Alarms and Preparing for Mastering	29
5.2.2 Fixture Position Master	30
5.2.3 Zero Position Mastering	38
5.2.4 Quick Mastering	41
5.2.5 QUICK MASTERING FOR SINGLE AXIS	43
5.2.6 Single Axis Mastering	45
5.2.7 Mastering Data Entry	48
5.2.8 VERIFYING MASTERING	50
6 REPLACING PARTS	51
6.1 REPLACING THE MOTOR	52
6.1.1 In the case of 300kg payload (Hollow type), 300kg/500kg payload (Hollow type)	52

6.1.2	In the case of 1000kg/1500kg payload (Hollow type)	54
6.1.3	In the case of 1000 kg/1500kg payload (Compact type).....	55
6.2	REPLACING THE REDUCER	56
6.2.1	In the case of 300kg payload (Hollow type), 300kg/500kg payload (Hollow type).....	56
6.2.2	In the case of 1000 kg/1500kg payload (Hollow type)	58
6.2.3	In the case of 1000 kg/1500kg payload (Compact type).....	59
6.3	SEALANT APPLICATION (1000kg/1500kg payload (Hollow type)) (1000kg/1500kg payload (Compact type))	60
6.4	REPLACING THE GROUND BRUSH (for 300kg/500kg payload (Hollow type) Infinite continuous turn mechanical option)	62
6.5	REPLACING THE ROTARY JOINT (for 300kg/500kg payload (Hollow type) Infinite continuous turn mechanical option)	63
7	PIPING AND WIRING	64
7.1	CABLING (WHEN THE HARTING CONNECTOR OPTION IS SELECTED)	64
8	CABLE REPLACEMENT	65
8.1	REPLACING CABLES	66
II. CONNECTION		
1	POSITIONER OUTLINE DRAWING	73
1.1	OUTLINE DRAWING.....	73
2	MOUNTING DEVICES ON THE POSITIONER.....	76
2.1	POSITIONER LOAD CONDITION.....	76
2.2	CHANGING METHOD OF PAYLOAD SPECIFICATION.....	80
2.2.1	Method of executing KAREL program by using “Call program”.....	81
2.2.2	Method of executing KAREL program directly.....	84
3	TRANSPORTATION AND INSTALLATION	86
3.1	TRANSPORTATION.....	86
3.2	STORING THE POSITIONER	88
3.3	INSTALLATION	89
3.4	MAINTENANCE CLEARANCE.....	102
3.5	ASSEMBLING THE POSITIONER FOR INSTALLATION	104
3.6	INSTALLATION CONDITIONS.....	104
APPENDIX		
A	MAINTENANCE PARTS	107
B	MECHANICAL UNIT CIRCUIT DIAGRAMS	110
C	PERIODIC INSPECTION TABLE.....	112
D	STRENGTH OF BOLT AND BOLT TORQUE LIST	114

I. MAINTENANCE

JR AUTOMATION TECHNOLOGIES INC*
JDOWLING

JR AUTOMATION TECHNOLOGIES INC*
JDOWLING

1 CONFIGURATION

Fig. 1 shows the configuration of the mechanical unit.

The axis drive mechanism is configured in such a way that the flange base is rotated by reducing the rotation speed of an AC servo motor with a reducer.

The flange base is supported on the base through the reducer.

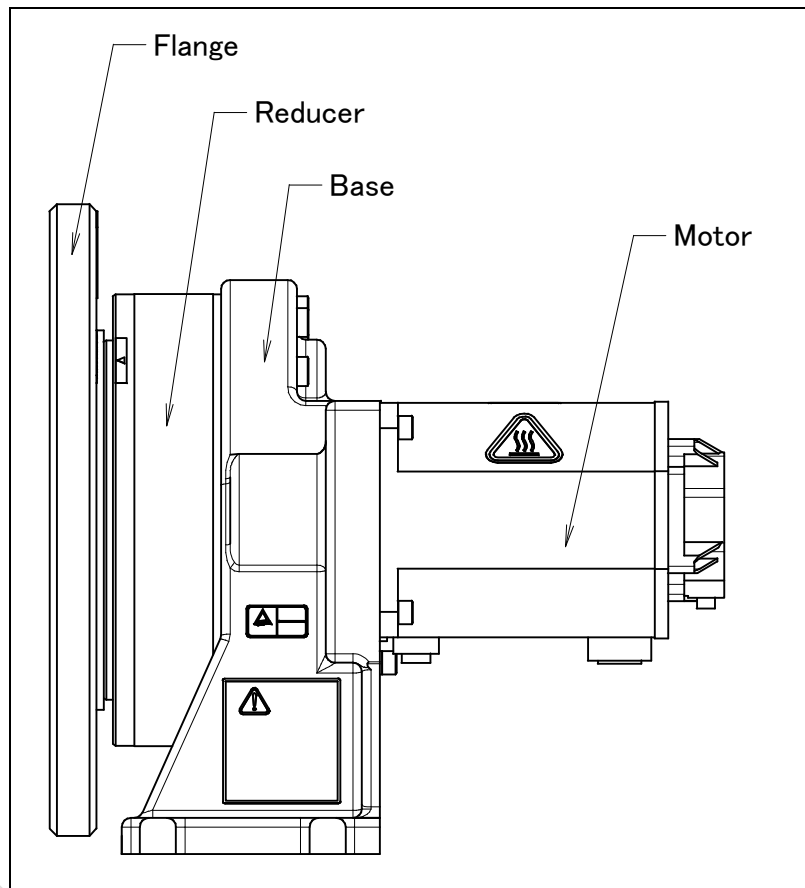

Fig. 1 Mechanical unit configuration

Refer to Appendix A about the major mechanical unit components.

2 CHECKS AND MAINTENANCE

Optimum performance of the positioner can be maintained by performing the periodic maintenance procedures presented in this chapter.

(See APPENDIX C PERIODIC MAINTENANCE TABLE.)

NOTE

The periodic maintenance procedures described in this chapter assume that the FANUC positioner is used for up to 3840 hours a year. In cases where the positioner use exceeds 3840 hours/year, adjust the given maintenance frequencies accordingly. The ratio of actual operation time/year vs. the 3840 hours/year should be used to calculate the new (higher) frequencies. For example, when using the positioner 7680 hours a year, the maintenance frequency should be doubled – i.e. the time interval should be divided by 2.

2.1 PERIODIC MAINTENANCE

2.1.1 Daily Checks

Clean each part, and visually check component parts for damage before daily system operation. Check the following items when necessary.

Check items	Check points and management
Oil seepage	Check there is oil on the sealed part of the joint. If there is an oil seepage, clean them. ⇒"MAINTENANCE 2.2.2 Confirmation of Oil Seepage"
Air control set	(When an air control set is used) ⇒"MAINTENANCE 2.2.3 Confirmation of the Air Control Set"
Vibration, abnormal noises	Check whether vibration or abnormal noises occur. When vibration or abnormal noises occur, perform measures referring to the following section: ⇒"MAINTENANCE 4.1 TROUBLESHOOTING"(symptom : Vibration, Noise)
Positioning accuracy	Check that the taught positions of the robot have not deviated from the previously taught positions. When the displacement occurs, perform the measures as described in the following section: ⇒" MAINTENANCE 4.1 TROUBLESHOOTING" (Symptom : Displacement)
Peripheral devices for proper operation	Check whether the peripheral devices operate properly according to commands from the positioner and the peripheral devices.
Brakes for each axis	Check that the flange mounting surface drops 5 mm or less when servo power is turned off. If the flange mounting surface drops, perform the measures as described in the following section: ⇒"MAINTENANCE 4.1 TROUBLESHOOTING"(symptom : Dropping axis)
Warnings	Check whether unexpected warnings occur in the alarm screen on the teach pendant. If unexpected warnings occur, perform the measures as described in the following manual: ⇒"R-30iB/R-30iB Mate/R-30iB Plus/R-30iB Mate Plus CONTROLLER OPERATOR'S MANUAL (Alarm Code List)(B-83284EN-1) etc."

2.1.2 Periodic Check and Maintenance

Check the following items at the intervals recommended below based on the period or the accumulated operating time, whichever comes first. (○ : Item needs to be performed.)

Check and maintenance intervals (Period, Operation accumulated time)						Check and maintenance item	Check points, management and maintenance method	Periodic maintenance No.
1 months 320h	3 months 960h	1 year 3840h	1.5 years 5760h	3 years 11520h	4 years 15360h			
○						Supply conductive grease (Infinite continuous turn mechanical option)	Supply grease so that grease of the auto grease cup comes to the middle of the bottom surface and the red line. Refer to Section 3.4 of MAINTENANCE.	1
○						Check the abrasion of the ground brush (Infinite continuous turn mechanical option)	Check the abrasion of the ground brush electrode does not come to the mark line. If it comes to here, replace the ground brush. Refer to Section 6.4 of MAINTENANCE.	2
○ Only 1st check						Cleaning the controller ventilation system	Confirm that the controller ventilation system is not dusty. If dust has accumulated, remove it.	12
	○					Check for external damage or peeling paint	Check whether the robot has external damage or peeling paint due to contact with the peripheral equipment. If unintended contact has occurred, eliminate the cause. Also, if the external damage is serious, and causes a problem in which the robot will not operate, replace the damaged parts.	3
	○					Check for water	Check whether the positioner is subjected to water or cutting oils. If water is found, remove the cause and wipe off the liquid.	4
	○ Only 1st check	○				Check for damages to the teach pendant cable, the operation box connection cable or the robot connection cable	Check whether the cable connected to the teach pendant, the operation box and the positioner are unevenly twisted or damaged. If damage is found, replace the damaged cables.	11
	○ Only 1st check	○				Check the connection of each axis motor and other exposed connectors	Check the connection of each axis motor and other exposed connectors.	6

2. CHECKS AND MAINTENANCE

B-82545EN/06

Check and maintenance intervals (Period, Operation accumulated time)						Check and maintenance item	Check points, management and maintenance method	Periodic maintenance No.
1 months 320h	3 months 960h	1 year 3840h	1.5 years 5760h	3 years 11520h	4 years 15360h			
	○ Only 1st check	○				Retightening the flange mounting bolts, cover bolts and external main bolts	Retighten the cover bolts, bolts fixing fixtures to the flange surface, positioner mounting bolts, J2-axis motor cover bolts, bolts to be removed for inspection. Refer to the recommended bolt tightening torque guidelines at the end of the manual. An adhesive to prevent bolts from loosening is applied to some bolts. If the bolts are tightened with greater than the recommended torque, the adhesive might be removed. Therefore, follow the recommended bolt tightening torque guidelines when retightening the bolts.	7
	○ Only 1st check	○				Clean spatters, sawdust and dust	Check that spatters, sawdust, or dust does not exist on the positioner main body. If dust has accumulated, remove it. Especially, clean the robot movable parts well (each joint).	8
		○				Replacing the mechanical unit batteries	Replace the mechanical unit batteries ⇒"MAINTENANCE 3.3 BATTERY REPLACEMENT"	9
			○			Replacing the greas of reducers	Replace the grease of each axis reducer and gearbox ⇒"MAINTENANCE 3.1 GREASE REPLACEMENT"	10
					○	Replacing the controller batteries	Replace the controller batteries ⇒Chapter 7 Replacing batteries of R-30iB/R-30iB Plus CONTROLLER MAINTENANCE MANUAL (B-83195EN) etc."	13

2.2 CHECK POINTS

2.2.1 Supply conductive grease, check the abrasion of the ground brush (for 300kg/500kg payload (Hollow type) Infinite continuous turn mechanical option)

When the Infinite continuous turn mechanical option (A05B-1220-J117) is specified, check the following items at the intervals recommended below based on first one-month or 320 hours, which ever comes first. Additional inspection areas and times should be added to the table according to the positioner's working conditions, environment, etc.

Item	Check items	Check points
1	Supply conductive grease	Supply grease so that grease of the auto grease cup comes to the middle of the bottom surface and the red line.
2	Check the abrasion of the ground brush	Check the abrasion of the ground brush electrode does not come to the mark line. If it comes to here, replace the ground brush. Refer to Section 6.4 of MAINTENANCE.

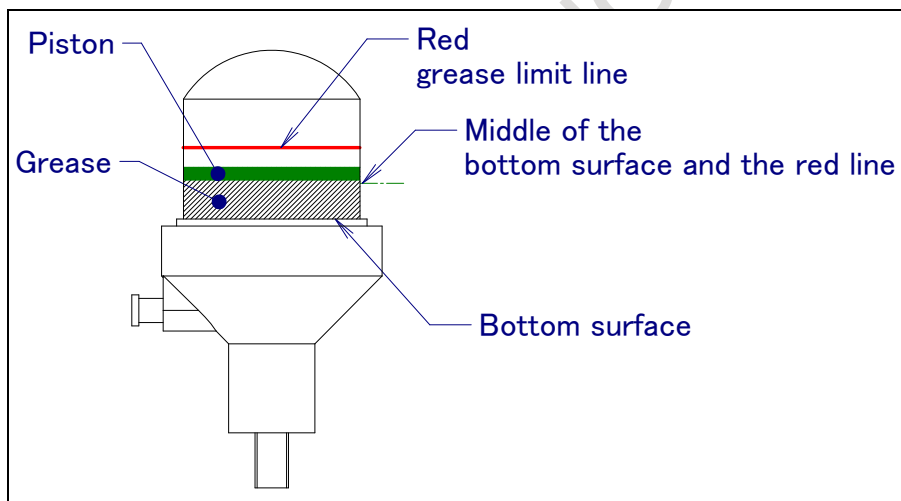

Fig. 2.2.1 (a) Auto grease cup

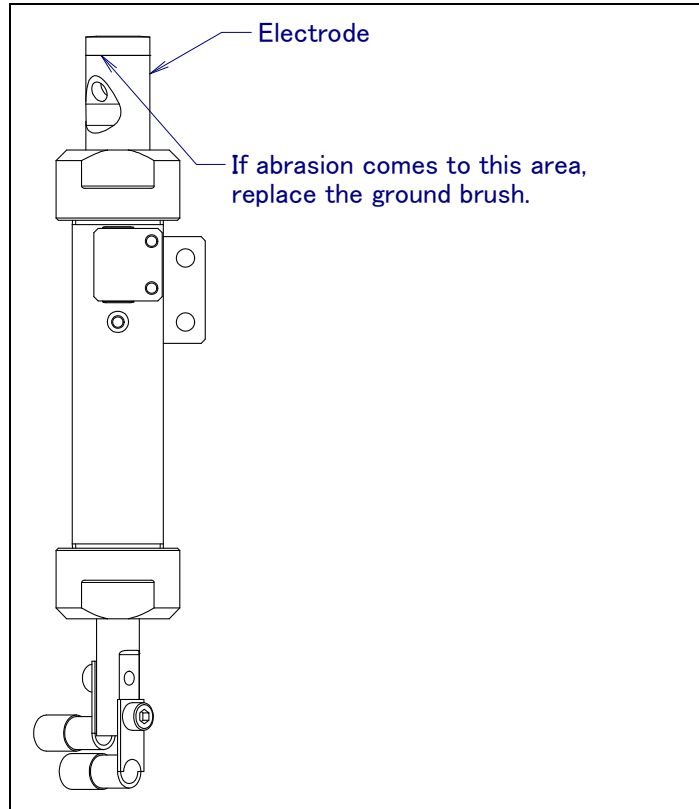

Fig. 2.2.1 (b) Ground brush

2.2.2 Confirmation of Oil Seepage

Check items

Check to see whether there is an oil seepage on the rotating parts of each joint axis.

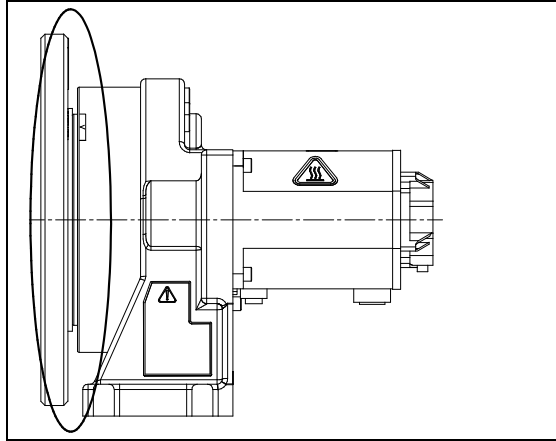

Fig. 2.2.2 Check points of oil seepage

Management

- Oil might accumulate on the outside of the seal lip depending on the movement condition or environment of the axis. If the oil viscosity changes, the oil might drip depending on the axis movement. To prevent oil spots, be sure to wipe away any accumulated oil under the axis components in Fig. 2.2.2 before you operate the positioner.
- In case of oil seepage, please consider replacing the grease. This replacement potentially can help improving the seepage situation.

⚠ WARNING

Hot grease might eject suddenly when you open the grease outlet. Attach bags for collecting grease, and use appropriate protective equipment such as heat-resistant gloves, protective glasses, a face shield, or a body suit if necessary.

- If you must wipe oil frequently, and opening the grease outlet does not stop the seepage, perform the measures below.
⇒ "MAINTENANCE 4.1 TROUBLESHOOTING" (symptom : Grease leakage)

2.2.3 Confirmation of the Air Control Set

When an air control set is used, check the items below.

Item	Check items	Check points
1	Air pressure	Check the air pressure using the pressure gauge on the air regulator as shown in Fig. 2.2.3. If it does not meet the specified pressure of 0.49 to 0.69 MPA (5-7 kgf/cm ²), adjust it using the regulator pressure-setting handle.
2	Lubricator oil mist quantity	Check the number of oil drops during wrist or hand motion. If it does not meet the specified value (1 drop/10-20 sec), adjust it using the lubricator control knob. Under normal usage, the lubricator will be empty in about 10 to 20 days.
3	Lubricator oil level	Check to see that the air control set oil level is within the specified level.
4	Leakage from hose	Check the joints, tubes, etc. for leaks. Repair leaks, or replace parts as required.
5	Drain	Check the drain and empty it. When the quantity of liquid in the drain is excessive, examine the setting of the air dryer on the air supply side.

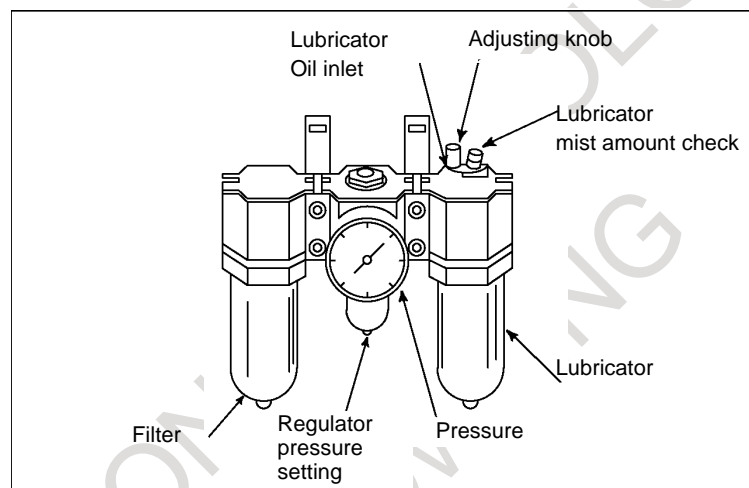

Fig. 2.2.3 Air control set (option)

2.3 MAINTENANCE TOOLS

You should have the following instruments and tools ready for maintenance.

Measuring instruments

Instrument	Condition	Use
Dial gauge	1/100mm	For positioning precision and backlash measurement
Vernier calipers	150mm	

Tools

Parts name	Remarks	Use
Cross-head screwdrivers	Large, medium, small	
Straight-head screwdrivers	Large, medium, small	
Nut driver	7 mm wide across flats	For grease nipple
Hexagon wrench set	width across flats (mm) 2.5, 3, 5, 6, 8, 10, 12, 14, 17	
Torque wrench		
Long T wrenches	M5, M6	
Adjustable wrench	Medium and small sizes	
Pliers		
Cutting pliers		
Cutting nippers		
Offset box end wrench		
Pliers for C-retaining ring		
Seal tape		
LOCTITE 243, 263, 675		
Grease gun		
Slings		
Separator		
Gear puller		
Flashlight		

3 PERIODIC MAINTENANCE

3.1 GREASE REPLACEMENT

According to below, replace the grease of the reducer, at the intervals based on every 3 years or 11520 hours, which ever comes first. For greasing points, see Figs. 3.1 (a) to (c).

- 1 Remove the seal bolts and taper plugs of the grease outlets shown in Figs. 3.1 (a) to (c).
- 2 Attach the grease nipple supplied with the positioner.
- 3 Apply the grease specified in Table 3.1 (a) to (c) until the old grease is replaced and the new grease is output from the grease nipple. Use grease outlet 1 shown in Figs. 3.1 (a) to (c). Only when grease outlet 1 cannot be used due to the installation state of the jig, use grease outlet 2. At this time, confirm that the same amount of the old grease as that of applied grease has been output to prevent the grease bath from overflowing.
- 4 After applying grease, release the remaining pressure in the grease bath as instructed by the procedure in Section 3.2.

CAUTION

When reusing a grease nipple once used, wind sealing tape around the screw.

**Table 3.1 (a) Grease to be replaced at regular intervals of three years (11520 hours)
(300kg payload (Hollow type)), (300kg/500kg payload (Hollow type))**

	Specified grease	Amount of grease to be applied	Gun tip pressure	Positioner posture when greased
	Kyodo Yushi			
Reducer	VIGOGREASE RE0 (Specification: A98L-0040-0174)	About 980 ml	0.1 MPa or less (NOTE)	Grease outlet 1 is used : 0° Grease outlet 2 is used : free

**Table 3.1 (b) Grease to be replaced at regular intervals of three years (11520 hours)
(1000kg/1500kg payload (Hollow type))**

	Specified grease	Amount of grease to be applied	Gun tip pressure	Positioner posture when greased
	Kyodo Yushi			
Reducer	VIGOGREASE RE0 (Specification: A98L-0040-0174)	About 5500 ml	0.15 MPa or less (NOTE)	Grease outlet 1 is used : 0° Grease outlet 2 is used : free

**Table 3.1 (c) Grease to be replaced at regular intervals of three years (11520 hours)
(1000kg/1500kg payload (Compact type))**

	Specified grease	Amount of grease to be applied	Gun tip pressure	Positioner posture when greased
	Kyodo Yushi			
Reducer	VIGOGREASE RE0 (Specification: A98L-0040-0174)	About 1193 ml	0.15 MPa or less (NOTE)	free

NOTE

When a manual pump is used for greasing, the standard rate is one pumping cycles per two seconds.

WARNING

Hot grease might eject suddenly when you open the grease outlet. Attach bags for collecting grease, and use appropriate protective equipment such as heat-resistant gloves, protective glasses, a face shield, or a body suit if necessary.

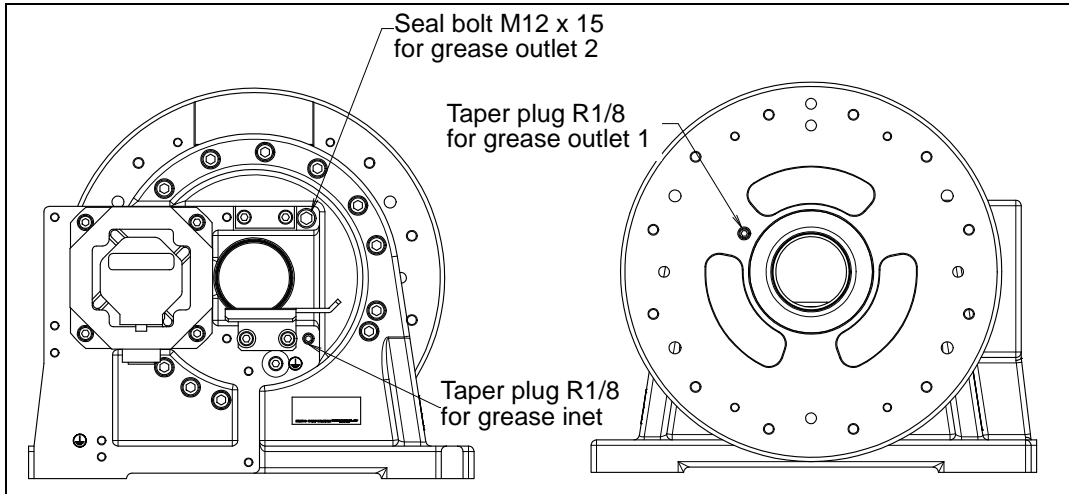

Fig. 3.1 (a) Grease inlet and outlet (300kg payload (Hollow type)), (300kg/500kg payload (Hollow type))

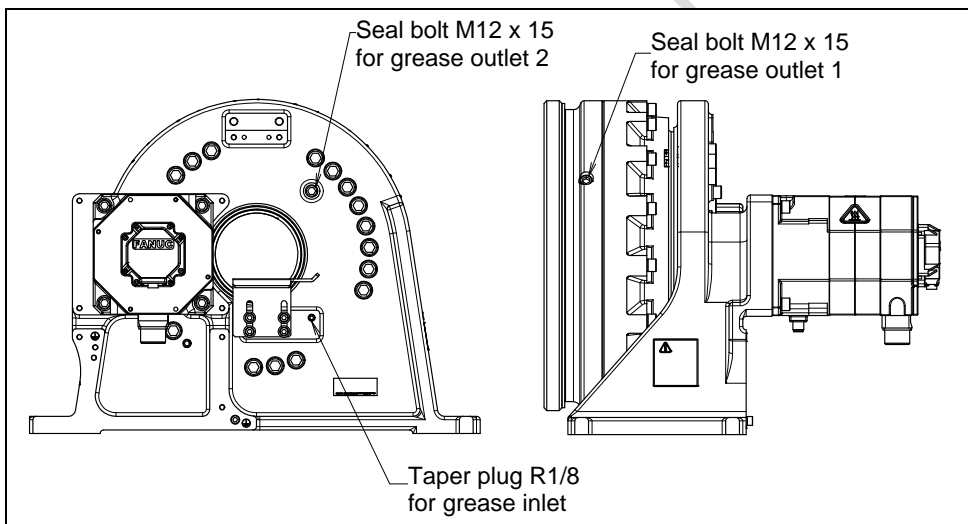

Fig. 3.1 (b) Grease inlet and outlet (1000kg/1500kg payload (Hollow type))

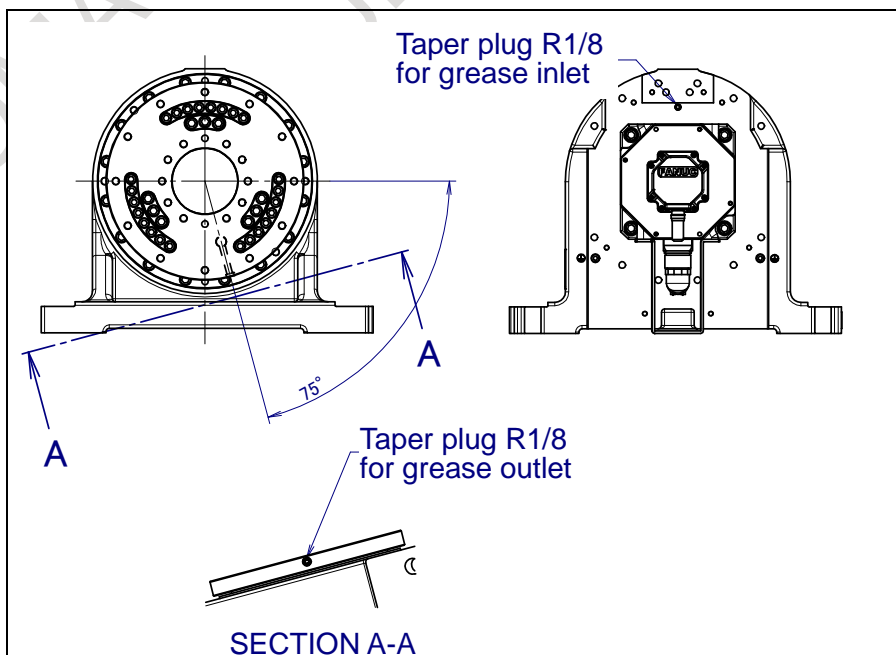

Fig. 3.1 (c) Grease inlet and outlet (1000kg/1500kg payload (Compact type))

Table 3.1 (d) Specification of seal bolts, taper plug and grease nipple

Parts name	Specification
Seal bolt (M8 x 10)	A97L-0218-0417#121515
Taper plug (R1/8)	A97L-0001-0436#2-1D
Grease nipple	A97L-0218-0013#A110

⚠ CAUTION

Failure to follow proper lubrication procedures may cause the suddenly increase of the grease bath internal pressure and the damage to the seal, which could lead to grease leakage and abnormal operation. When greasing, observe the following cautions.

- 1 Before starting to grease, remove the plug or bolt from the grease outlet to allow the grease to come out.
- 2 Supply grease slowly, using a manual pump. (once per two seconds)
- 3 Whenever possible, avoid using an air pump, which is powered by the factory air supply. If the use of an air pump is unavoidable, supply grease with the pump at a pressure lower than or equal to the gun tip pressure (see Table 3.1 (a) to (c)).
- 4 Use specified grease. Use of non-approved grease may damage the reducer or lead to other problems.
- 5 After greasing, release remaining pressure from the grease bath using the procedure given in Section 3.2, and then close the grease outlet.
- 6 To prevent slipping accidents and catching fire, completely remove any excess grease from the floor or robot.

3.2 PROCEDURE FOR RELEASING THE GREASE REMAINING PREESSURE

After applying grease, to release remaining pressure from the grease bath, perform a repetitive operation with a motion angle of at least 60 degrees and OVR100% for 10 minutes or more while leaving the grease inlets and outlets open.

Under the grease inlets and outlets, attach bags for collecting grease so that grease does not spatter when it comes out of the inlets or outlets.

If the above operation cannot be performed due to the environment of the positioner, prolong the operating time so that an equivalent operation can be performed. (If only a motion angle of 30 degrees can be set, perform an operation for 20 minutes or more.) After completion of the operation, attach the plugs and seal bolts to the grease inlets and outlets. When reusing the taper plugs and seal bolts, be sure to seal them with seal tape.

3.3 BATTERY REPLACEMENT

A backup battery is used to keep the reference-position data for the positioner. The battery needs to be replaced at regular intervals of one year and half. Follow this procedure for battery replacement.

This section describes the battery replacement procedure to follow when the HARTING connector option is selected. Replace the battery on the controller side when the HARTING connector option is not selected.

- 1 Press the EMERGENCY STOP button to prohibit the robot and positioner motion.

⚠ CAUTION

Be sure to keep controller power turned on. Replacing the batteries with the power turned off causes all current position data to be lost. Therefore, mastering will be required again.

- 2 Uncap the battery case.
- 3 Take out the battery from the battery case.
- 4 Insert a new battery into the battery case while paying attention to the polarity of the battery.
- 5 Cap the battery case.

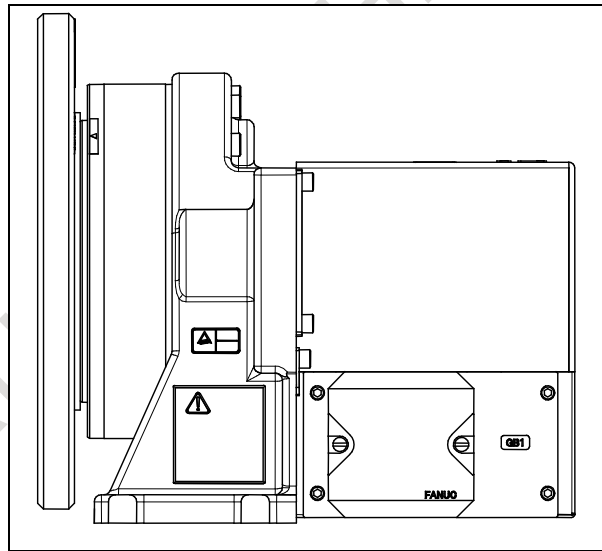
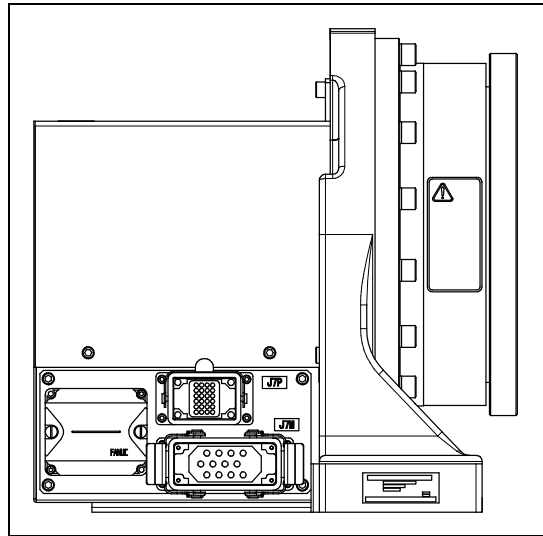

Fig. 3.3 (a) Battery replacement 1
(300kg load capacity (Hollow type)), (300kg/500kg load capacity (Hollow type)),
(1000kg/1500kg payload (Hollow type))



**Fig. 3.3 (b) Battery replacement 1
(100kg/1500kg payload (Compact type))**

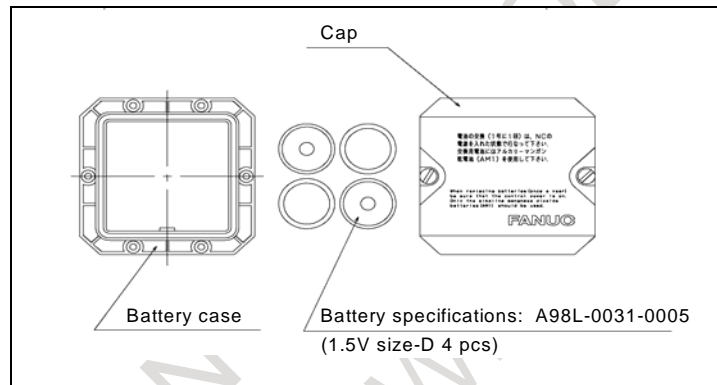

Fig. 3.3 (c) Battery replacement 2

3.4 GREASING (for 300kg/500kg payload (Hollow type) Infinite continuous turn mechanical option)

When Infinite continuous turn mechanical option (A05B-1220-J117) is specified, Supply grease to prevent the conductivity grease becomes empty. Refer to Fig.3.4 about greasing point.

- 1 Loosen two mounting bolts and remove the cover.
- 2 Apply specified conductive grease to the auto grease cup. Supply grease until grease come to the red limit line.
- 3 Attach the cover, tighten the mounting bolts.

Table 3.4 Grease for auto grease cup

	Capacity	Specified conductive grease
Auto grease cup	About 70ml	Kyodo Yushi Multemp ELP (Spec. : A98L-0040-0262)

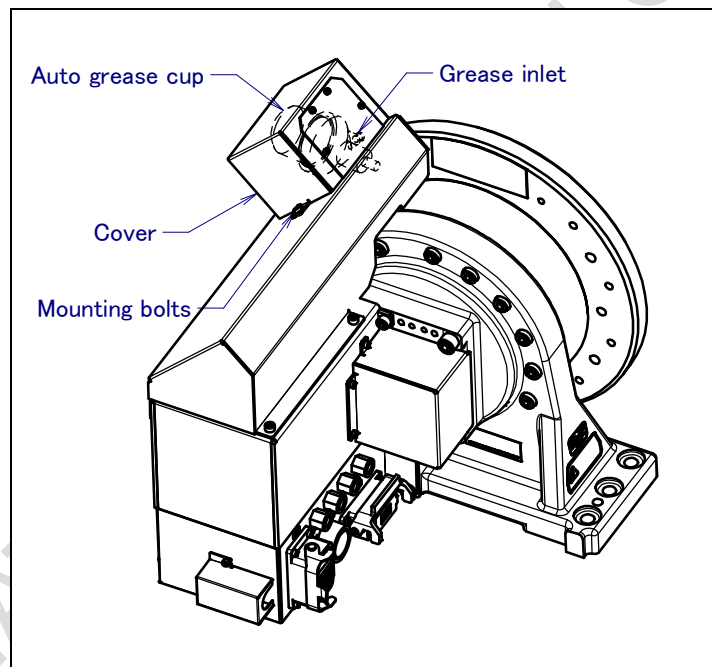

Fig. 3.4 Greasing

4 TROUBLESHOOTING

The source of mechanical unit problems may be difficult to locate because of overlapping causes. Problems may become further complicated, if they are not corrected properly. Therefore, you must keep an accurate record of problems and take proper corrective actions.

4.1 TROUBLESHOOTING

Table 4.1 (a) shows the problems that may occur in the mechanical unit and their probable causes. If you cannot pinpoint the cause of a failure or which measures to take, contact your local FANUC representative.

Table 4.1 (a) Troubleshooting

Symptom	Description	Cause	Measure
Vibration noise	<ul style="list-style-type: none"> - The base lifts off the floor plate as the positioner operates. - There is a gap between the base and floor plate. - A base retaining bolt is loose. 	[Base fastening] <ul style="list-style-type: none"> - It is likely that the positioner base is not securely fastened to the floor plate. - Probable causes are a loose bolt, an insufficient degree of surface flatness, or foreign material caught. - If the positioner is not securely fastened to the floor plate, the base lifts the floor plate as the positioner operates, allowing the base and floor plates to strike each other. That, in turn, leads to vibration. 	<ul style="list-style-type: none"> - If a bolt is loose, apply LOCTITE and tighten it to the appropriate torque. - Adjust the floor plate surface flatness to within the specified tolerance. - If there is any foreign material between the base and floor plate, remove it.
	<ul style="list-style-type: none"> - The rack or floor vibrates during operation of the positioner. 	[Rack or floor] <ul style="list-style-type: none"> - It is likely that the rack or floor is not rigid enough. - If they are not rigid enough, counterforce can deform the rack or floor, and cause vibration. 	<ul style="list-style-type: none"> - Reinforce the rack or floor to make it more rigid. - If it is impossible to reinforce the rack or floor, modify the robot control program; doing so might reduce the amount of vibration.
	<ul style="list-style-type: none"> - Vibration becomes more serious when the positioner adopts a specific posture. - If the operating speed of the positioner is reduced, vibration stops. - Vibration is most noticeable when the positioner is accelerating. 	[Overload] <ul style="list-style-type: none"> - It is likely that the load on the positioner is greater than the maximum rating. - It is likely that the positioner control program is too demanding for the positioner hardware. - It is likely that the ACCELERATION value is excessive. 	<ul style="list-style-type: none"> - Check the maximum load that the positioner can handle once more. If the positioner is found to be overloaded, reduce the load, or modify the positioner control program. - Vibration in a specific portion can be reduced by modifying the robot control program while slowing the positioner and reducing its acceleration (to minimize the influence on the entire cycle time).

Symptom	Description	Cause	Measure
Vibration noise (Continued)	<ul style="list-style-type: none"> - Vibration was first noticed after the positioner collided with an object or the positioner was overloaded for a long period. - The grease has not been exchanged for a long period. 	<p>[Broken gear, bearing, or reducer]</p> <ul style="list-style-type: none"> - It is likely that collision or overload applied an excessive force on the drive mechanism, thus damaging the gear tooth surface or rolling surface of a bearing, or reducer. - It is likely that prolonged use of the positioner while overloaded caused fretting of the gear tooth surface or rolling surface of a bearing, or reducer due to resulting metal fatigue. - It is likely that foreign material which was caught in a gear, bearing, or within a reducer caused damage on the gear tooth surface or rolling surface of the bearing, or reducer - It is likely that foreign material which was caught in a gear, bearing, or within a reducer cause vibration. - It is likely that, because the grease has not been changed for a long period, fretting occurred on the gear tooth surface or rolling surface of a bearing, or reducer due to metal fatigue. <p>These factors all generate cyclic vibration and noise.</p>	<ul style="list-style-type: none"> - Remove the motor, and replace the gear, the bearing, and the reducer. For the spec. of parts and the method of replacement, contact FANUC. - Using the positioner within its maximum rating prevents problems with the drive mechanism. - Regularly greasing with the specified grease can help prevent problems.

Symptom	Description	Cause	Measure
Vibration Noise (Continued)	- The cause of problem cannot be identified from examination of the floor, rack, or mechanical section.	<p>[Controller, cable, and motor]</p> <ul style="list-style-type: none"> - If a failure occurs in a controller circuit, preventing control commands from being supplied to the motor normally, or preventing motor information from being sent to the controller normally, vibration might occur. - Pulse coder defect may be the cause of the vibration as the motor cannot propagate the accurate position. - If the motor becomes defective, vibration might occur because the motor cannot deliver its rated performance. - If a robot connection cable has an intermittent break, vibration might occur. - If the power supply cable is about to be snapped, vibration might occur. - If the power source voltage drops below the rating, vibration might occur. - It may vibrate when an invalid value parameter was set. 	<ul style="list-style-type: none"> - Refer to the Controller Maintenance Manual for troubleshooting related to the controller and amplifier. - Replace the motor, and check whether vibration still occurs. For the method of replacement, contact your local FANUC representative. - Check whether the robot connection cable is damaged. If so, replace the connection cable, and check whether vibration still occurs. - Check whether the power cable jacket is damaged. If so, replace the power cable, and check whether vibration still occurs. - Check that the robot is supplied with the rated voltage. - Check that the robot control parameter is set to a valid value. If it is set to an invalid value, correct them. Contact your local FANUC representative for further information if necessary.
	- There is some relationship between the vibration of the positioner and the operation of a machine near the positioner.	<p>[Noise from a nearby machine]</p> <ul style="list-style-type: none"> - If the positioner is not grounded properly, electrical noise can be induced on the grounding wire, preventing commands from being transferred accurately, thus leading to vibration. - If the positioner is grounded at an unsuitable point, its grounding potential becomes unstable, and noise is likely to be induced on the grounding line, thus leading to vibration. 	<ul style="list-style-type: none"> - Connect the grounding wire firmly to ensure a reliable ground potential thereby preventing extraneous electrical noise.
	<ul style="list-style-type: none"> - There is an unusual sound after replacement of grease. - There is an unusual sound after a long period of time. - There is an unusual sound during operation at low speed. 	<ul style="list-style-type: none"> - There may be an unusual sound when using other than the specified grease. - Even for the specified grease, there may be an unusual sound during operation at low speed immediately after replacement or after a long period of time. 	<ul style="list-style-type: none"> - Use the specified grease. - When there is an abnormal noise even when using the specified grease, operate for one or two days as an experiment. Generally, the abnormal noise will disappear.

Symptom	Description	Cause	Measure
Rattling	<ul style="list-style-type: none"> - While the positioner is not supplied with power, pushing it with the hand causes part of the mechanical unit to wobble. - There is a gap on the mounting surface of the mechanical unit. 	<p>[Mechanical section coupling bolt]</p> <ul style="list-style-type: none"> - It is likely that overloading or a collision has loosened a mounting bolt in the positioner mechanical section. 	<ul style="list-style-type: none"> - Check that the following bolts are tight. If any of these bolts is loose, apply LOCTITE and tighten it to the appropriate torque. - Motor retaining bolt - Reducer retaining bolt - Reducer shaft retaining bolt - Base retaining bolt - End effector retaining bolt
	<ul style="list-style-type: none"> - Backlash is greater than the tolerance stated in the applicable maintenance manual. (See Section 4.2.) 	<p>[Increase in backlash]</p> <ul style="list-style-type: none"> - It is likely that excessive force applied to the drive mechanism, due to a collision or overloading, has broken a gear or the inside of the reducer, resulting in an increase in the amount of backlash. - It is likely that prolonged use in overload conditions has caused the tooth surfaces of a gear and the reducer to wear out, resulting in an increase in the amount of backlash. - It is likely that prolonged use without changing the grease has caused the tooth surfaces of a gear and the inside of the reducer to wear out, resulting in an increase in the amount of backlash. 	<ul style="list-style-type: none"> - Remove the motor, and check whether any of its gears are broken. If any gear is broken, replace it. - Check whether any other gear of the drive mechanism is damaged. If there are no damaged gears, replace the reducer. - If the reducer is broken, or if a gear tooth is missing, replace the relevant component. Also, remove all the grease from the gearbox and wash the inside of the gearbox. - After replacing the gear or reducer, add an appropriate amount of grease. - Using the positioner within its maximum rating prevents problems with the drive mechanism. - Regularly changing the grease with a specified type can help prevent problems.

Symptom	Description	Cause	Measure
Motor overheating	<ul style="list-style-type: none"> - The motor overheated due to a rise in temperature in the installation area. - After a cover was attached to the motor, the motor overheated. - After the robot control program or the load was changed, the motor overheated. 	<p>[Ambient temperature]</p> <ul style="list-style-type: none"> - It is likely that a rise in the ambient temperature or attaching the motor cover prevented the motor from releasing heat efficiently, thus leading to overheating. <p>[Operating condition]</p> <ul style="list-style-type: none"> - It is likely that the overcurrent is above the specified permissive average current 	<ul style="list-style-type: none"> - Reducing the ambient temperature is the most effective means of preventing overheat. - Having the surroundings of the motor well ventilated enables the motor to release heat efficiently, thus preventing overheating. - If there is a source of heat near the motor, it is advisable to install shielding to protect the motor from heat radiation. - Relaxing the robot control program and load condition is an effective way to reduce the average current. Thus, prevent overheating. - The teach pendant can monitor the average current. Check the average current when the robot control program launched.
	<ul style="list-style-type: none"> - After a control parameter was changed, the motor overheated. 	<p>[Parameter]</p> <ul style="list-style-type: none"> - If data input for a workpiece is invalid, the positioner cannot be accelerate or decelerate normally, so the average current increases, leading to overheating. 	<ul style="list-style-type: none"> - As for load setting, Input an appropriate parameter referring to Section 2.2 of CONNECTION.
	<ul style="list-style-type: none"> - Symptom other than stated above 	<p>[Mechanical section problems]</p> <ul style="list-style-type: none"> - It is likely that problems occurred in the mechanical unit drive mechanism, thus placing an excessive load on the motor. <p>[Motor problems]</p> <ul style="list-style-type: none"> - It is likely that a failure of the motor brake resulted in the motor running with the brake applied, thus placing an excessive load on the motor. - It is likely that a failure of the motor prevented it from delivering its rated performance, thus causing an excessive current to flow through the motor. 	<ul style="list-style-type: none"> - Repair the mechanical unit while referring to the above descriptions of vibration, noise, and rattling. - Check that, when the servo system is energized, the brake is released. If the brake remains applied to the motor all the time, replace the motor. - If the average current falls after the motor is replaced, it indicates that the first motor was faulty.

Symptom	Description	Cause	Measure
Grease leakage	<ul style="list-style-type: none"> - Grease is leaking from the mechanical unit. 	<p>[Poor sealing]</p> <ul style="list-style-type: none"> - Probable causes are a crack in the casting, a broken O-ring, a damaged oil seal, or a loose seal bolt. - A crack in a casting can occur due to excessive force that might be caused in collision. - An O-ring can be damaged if it is trapped or cut during disassembling or re-assembling. - An oil seal might be damaged if extraneous dust scratches the lip of the oil seal. - A loose seal bolt and grease nipple might allow grease to leak along the threads. 	<ul style="list-style-type: none"> - If a crack develops in the casting, sealant can be used as a quick-fix to prevent further grease leakage. However, the component should be replaced as soon as possible, because the crack might extend. - O-rings are used in the locations listed below. <ul style="list-style-type: none"> - Motor coupling section - Reducer (case and shaft) coupling section - Oil seals are used in the locations stated below. <ul style="list-style-type: none"> - Inside the reducer - Seal bolts and nipples are used in the locations stated below. <ul style="list-style-type: none"> - Grease inlet and outlet
Axis rotation	<ul style="list-style-type: none"> - An axis rotates because the brake does not function. - An axis rotates gradually when it should be at rest. 	<p>[Brake drive relay and motor]</p> <ul style="list-style-type: none"> - It is likely that brake drive relay contacts are stuck to each other to keep the brake current flowing, thus preventing the brake from operating when the motor is deenergized. - It is likely that the brake shoe has worn out or the brake main body is damaged, preventing the brake from operating efficiently. - It is likely that oil or grease has entered the motor, causing the brake to slip. 	<ul style="list-style-type: none"> - Check whether the brake drive relay contacts are stuck to each other. If they are found to be stuck, replace the relay. - Replace the motor after confirming whether the following symptoms have occurred. <ul style="list-style-type: none"> - Brake shoe is worn out - Brake main body is damaged - Oil soaked through the motor

Symptom	Description	Cause	Measure
Displacement	<ul style="list-style-type: none"> - The positioner operates at a point other than the taught position. - The repeatability is not within the tolerance. 	[Mechanical section problems] <ul style="list-style-type: none"> - If the repeatability is unstable, probable causes are a failure in the drive mechanism or a loose bolt. - If the repeatability becomes stable it is likely that a collision imposed an excessive load, leading to slipping on the base surface or the mating surface of an arm or reducer. - It is likely that the Pulsecoder is abnormal. 	<ul style="list-style-type: none"> - If the repeatability is unstable, repair the mechanical section by referring to the above descriptions of vibration, noise, and rattling. - If the repeatability is stable, correct the taught program. Variation will not occur unless another collision occurs. - If the Pulsecoder is abnormal, replace the motor or the Pulsecoder.
	<ul style="list-style-type: none"> - Displacement occurs only in a specific peripheral unit. 	[Peripheral unit displacement] <ul style="list-style-type: none"> - It is likely that an external force was applied to the peripheral unit, thus shifting its position relative to the positioner. 	<ul style="list-style-type: none"> - Correct the setting of the peripheral unit position. - Correct the taught program.
	<ul style="list-style-type: none"> - Displacement occurred after a parameter was changed. 	[Parameter] <ul style="list-style-type: none"> - It is likely that the mastering data was rewritten in such a way that the positioner origin was shifted. 	<ul style="list-style-type: none"> - Re-enter the previous mastering data, which is known to be correct. - If correct mastering data is unavailable, perform mastering again.
BZAL alarm occurred	<ul style="list-style-type: none"> - BZAL is displayed on the teach pendant screen 	<ul style="list-style-type: none"> - The voltage of the memory backup battery may be low. - The Pulsecoder cable may be defected. 	<ul style="list-style-type: none"> - Replace the battery. - Replace the cable.
Troubles related to arc welding	<ul style="list-style-type: none"> - Starting of an arc is not good. - An arc is unstable. - Beads are irregular. 	<ul style="list-style-type: none"> - The welding ground cable may be loosened or broken (NOTE). 	<ul style="list-style-type: none"> - Tighten the connection part of the ground cable. - Replace the ground cable.

NOTE

Arc welding troubles may be caused by a welding unit such as a welding power supply or torch. When a trouble occurs, see the manual of each unit to find the cause.

4.2 BACKLASH MEASUREMENT

Measurement method

- 1 Maintain the positioner in a specified posture. (See Fig. 4.2 (a))
- 2 Apply positive and negative loads to each axis as shown in Fig. 4.2 (a).
- 3 Remove the loads and measure the displacement.

Apply positive and negative loads three times and then remove the loads. Calculate the average of the displacements in the second and third measurements as the backlash.

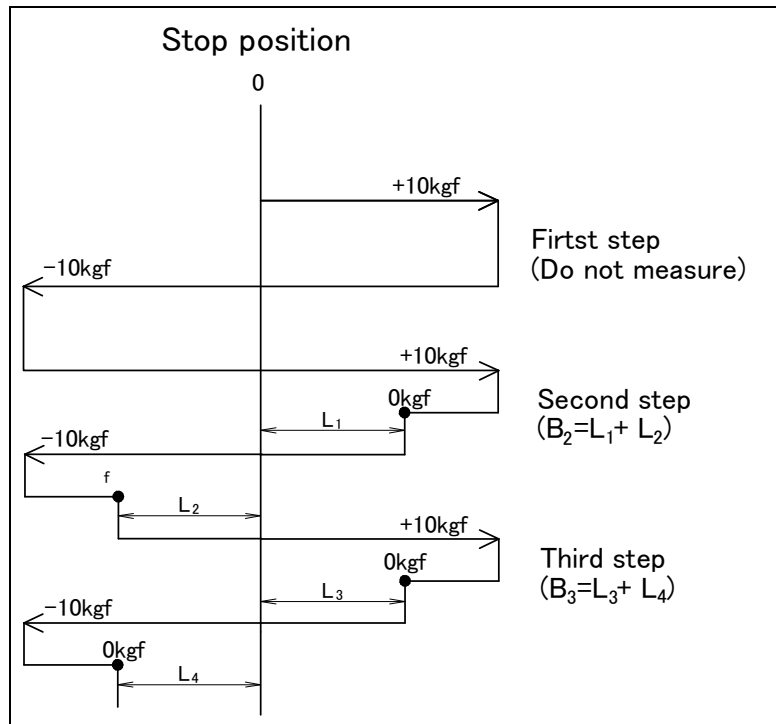

Fig. 4.2 (a) Backlash Measurement Method

Backlash B is calculated using the following expression:

$$B = \frac{B_2 + B_3}{2}$$

Table 4.2 (a) Backlash measurement posture and measurement position

Measured posture	Measurement position (mm)
0°	See fig 4.2 (b)

Table 4.2 (b) Backlash allowable rattling of each axis
(300kg payload (hollow type)), (300kg/500kg payload (Hollow type)),

Angle conversion (arc-min)	2.5
Displacement conversion (mm)	0.127
Distance from rotation center to measurement position (mm)	175

Table 4.2 (c) Backlash allowable rattling of each axis (1000kg/1500kg payload (Hollow type))

Angle conversion (arc-min)	2.5
Displacement conversion (mm)	0.164
Distance from rotation center to measurement position (mm)	225

Table 4.2 (d) Backlash allowable rattling of each axis (1000kg/1500kg payload (Compact type))

Angle conversion (arc-min)	2.5
Displacement conversion (mm)	0.109
Distance from rotation center to measurement position (mm)	150

NOTE

The displacement conversion value indicates play in the direction of rotation from the center of the axis at the distance shown in brackets.

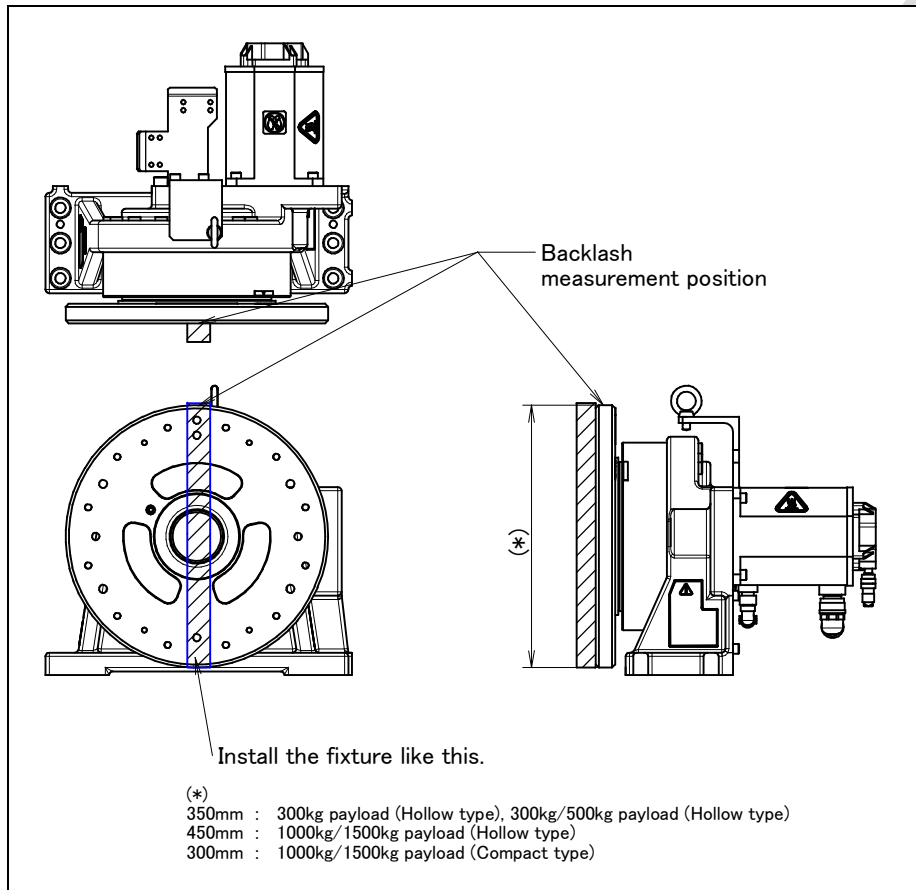

Fig. 4.2 (b) Backlash measurement position

4.3 COMPONENT REPLACEMENT AND ADJUSTMENT ITEMS

Adjustments are needed after a component is replaced.

The following table lists components and the adjustment items that must be made after their replacement.

After replacing a component, make necessary adjustments according to this table.

Component replacement or function change	Adjustment item
Cable replacement	Quick mastering
Battery replacement (The battery should be replaced once 1.5 years.)	Replace the battery with the power kept on. No adjustment is needed.

5 ADJUSTMENTS

Each part of the mechanical units of a positioner is set to the best condition before the positioner is shipped to the customer. The customer does not need to make adjustments on the positioner when it is delivered. If a mechanical unit of the positioner has a large backlash because of a long-term use or component replacement, make adjustments according to this section.

5.1 REFERENCE POSITION AND MOVING RANGE

Zero point and software motion limits are provided for controlled axis. Exceeding the software motion limit of a controlled axis is called overtravel (OT). Overtravel is detected at both ends of the motion limit for each axis. The positioner cannot exceed the software motion limit unless there is a failure of the system causing loss of zero point position or there is a system error.

Fig. 5.1 (a) shows the zero point and motion limit (stroke).

Fig. 5.1 (b) shows the motion direction (+/-).

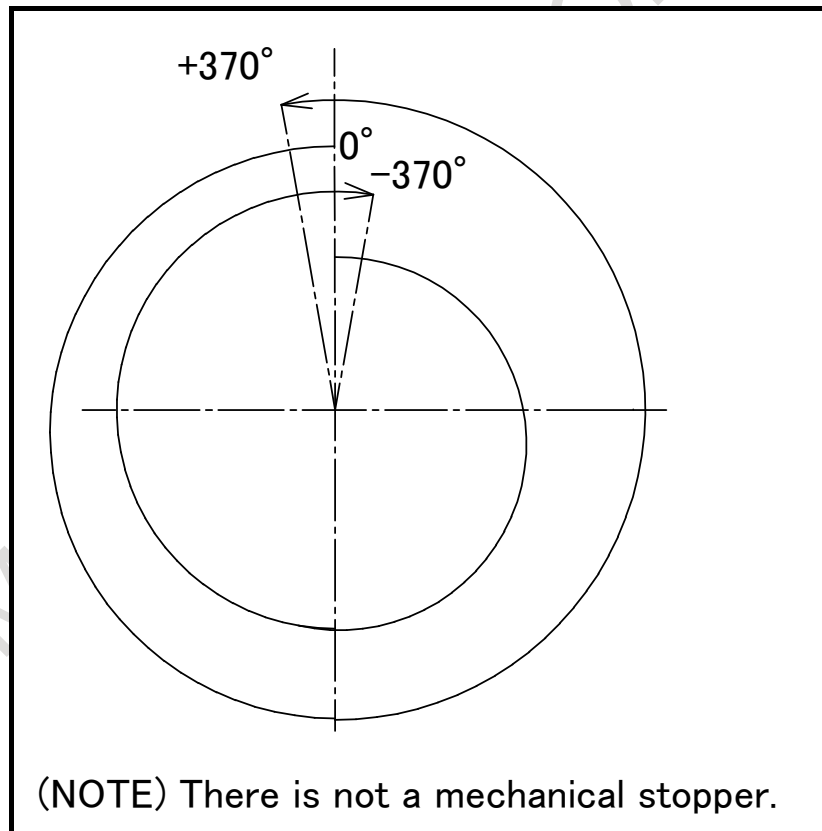

Fig. 5.1 (a) Axis swiveling

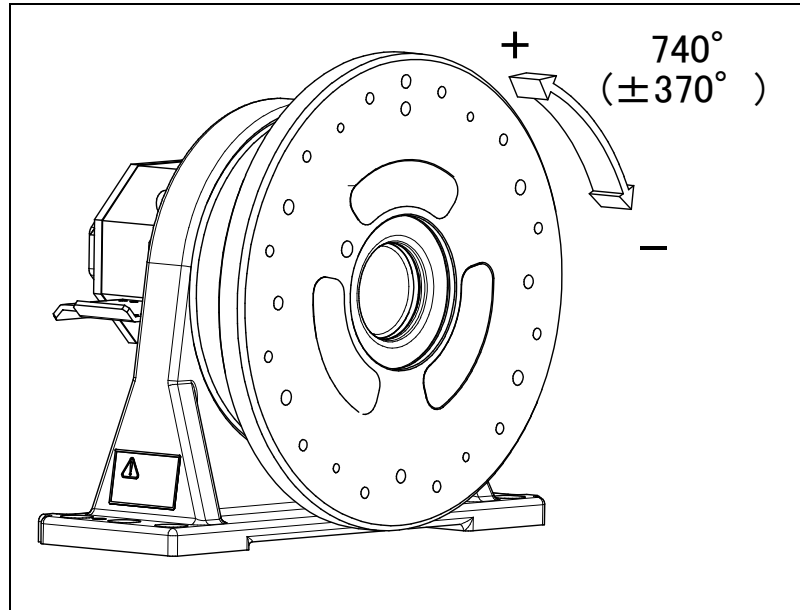

Fig. 5.1 (b) Axis motion direction

5.2 MASTERING

Mastering method

Table 5.2 describes the following mastering methods. If 7DC2 (V8.20P) or former software is installed, "Quick Mastering for Single Axis" has not been supported.

Table 5.2 Type of mastering

Fixture position mastering	This is performed using a mastering fixture before the machine is shipped from the factory.
Zero-position mastering (witness mark mastering)	This is performed with all axes set at the 0-degree position. A zero-position mark (witness mark) is attached to each robot axis. This mastering is performed with all axes aligned to their respective witness marks.
Quick mastering	This is performed at a user-specified position. The corresponding count value is obtained from the rotation count of the Pulsecoder connected to the relevant motor and the rotation angle within one rotation. Quick mastering uses the fact that the absolute value of a rotation angle within one rotation will not be lost. (All axes at the same time)
Quick mastering for single axis	This is performed at a user-specified position for one axis. The corresponding count value is obtained from the rotation count of the Pulsecoder connected to the relevant motor and the rotation angle within one rotation. Quick mastering uses the fact that the absolute value of a rotation angle within one rotation will not be lost.
Single-axis mastering	This is performed for one axis at a time. The mastering position for each axis can be specified by the user. This is useful in performing mastering on a specific axis.
Mastering data entry	Mastering data is entered directly.

Once mastering is performed, it is necessary to carry out positioning, or calibration. Positioning is an operation in which the controller reads the current pulse count value to sense the current position of the positioner.

If the backup batteries for the pulsecoder go dead during cable replacement, quick mastering can be performed, resetting the positioner exactly to its initial position by calibration.

If replacement of the motors, reducers, or other parts causes mechanical changes in the phases of the pulsecoder, quick mastering cannot be performed. In this case, perform fixture position mastering for accurate position calibration.

⚠ CAUTION

- 1 If mastering is performed incorrectly, the positioner may behave unexpectedly. This is very dangerous. Therefore, the positioning screen is designed to appear only when the \$MASTER_ENB system variable is 1 or 2. After performing positioning, press F5 [DONE] on the positioning screen. The \$MASTER_ENB system variable is reset to 0 automatically, thus hiding the positioning screen.
- 2 It is recommended that you back up the current mastering data before performing mastering.

5.2.1 Resetting Alarms and Preparing for Mastering

Before performing mastering because a motor has been replaced, it is necessary to release the relevant alarm and display the positioning menu.

Alarm displayed

“SRVO-062 BZAL” or “SRVO-075 Pulse not established”

Procedure

- 1 Display the positioning menu by following the steps 1 to 6.
 - 1 Press the [MENU] key.
 - 2 Press [0 NEXT] and select [6 SYSTEM].
 - 3 Press F1 ([TYPE]), and select [Variable] from the menu.
 - 4 Place the cursor on \$MASTER_ENB, then key in “1” and press the [ENTER] key.
 - 5 Press F1 ([TYPE]), and select [Master/Cal] from the menu.
 - 6 Select the desired mastering type from the [Master/Cal] menu.
- 2 To reset the “SRVO-062 BZAL” alarm, follow steps 1 to 5.
 - 1 Press the [MENU] key.
 - 2 Press [0 NEXT] and select [6 SYSTEM].
 - 3 Press F1 ([TYPE]), and select [Master/Cal] from the menu.
 - 4 Press F3 ([RES_PCA]), then press F4 ([YES]).
 - 5 Cycle power of the controller.
- 3 To reset the “SRVO-075 Pulse not established” alarm, follow the steps 1 to 2.
 - 1 After cycling controller power, the message “SRVO-075 Pulse not established” appears again.
 - 2 Move the axis for which the message mentioned above has appeared in either direction till the alarm disappears when you press the [RESET] key.

5.2.2 Fixture Position Master

Fixture position mastering is performed using a mastering fixture. This mastering is carried out in the predetermined fixture position.

Fixture position mastering is accurate because a dedicated mastering fixture is used. Fixture position mastering is not required in daily operations because it is factory-performed.

When mastering the positioner, arrange the positioner to meet the following conditions.

- Make the positioner mounting base horizontal.
(Set the positioner mounting surface so that the levelness of the entire surface is 1 mm or less.)
- Remove the hand and other parts from the wrist.
- Set the positioner in the condition protected from an external force.



CAUTION

Be extremely careful in moving the positioner during mastering because an axis movement range is not checked.

Assembling mastering fixtures

Attach the mastering fixture to the positioner as shown in Fig. 5.2.2 (a) to (h).

Remove the seal from the mastering fixture attaching surface.

Be sure to restore the original condition after completion of mastering.

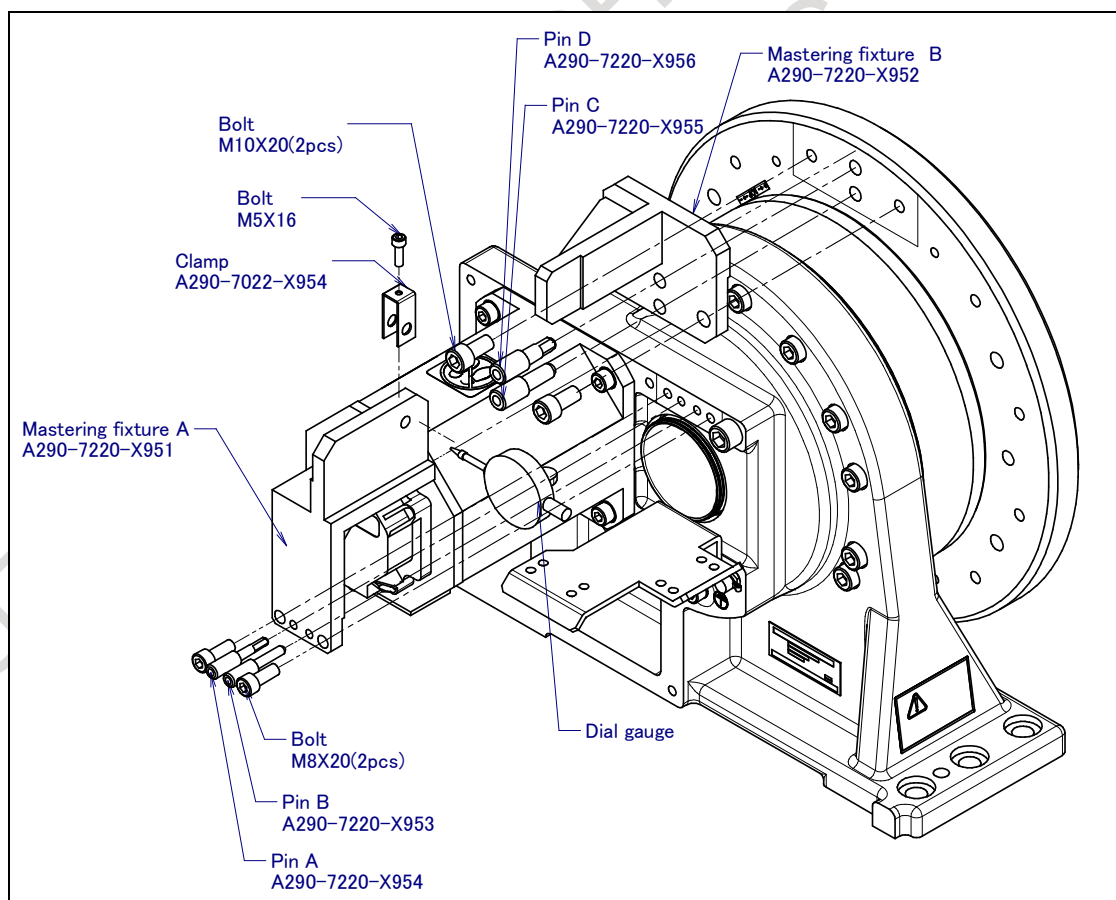

Fig. 5.2.2 (a) Attaching the mastering fixture to the 1-axis positioner (300kg payload (Hollow type)), (300kg/500kg payload (Hollow type))

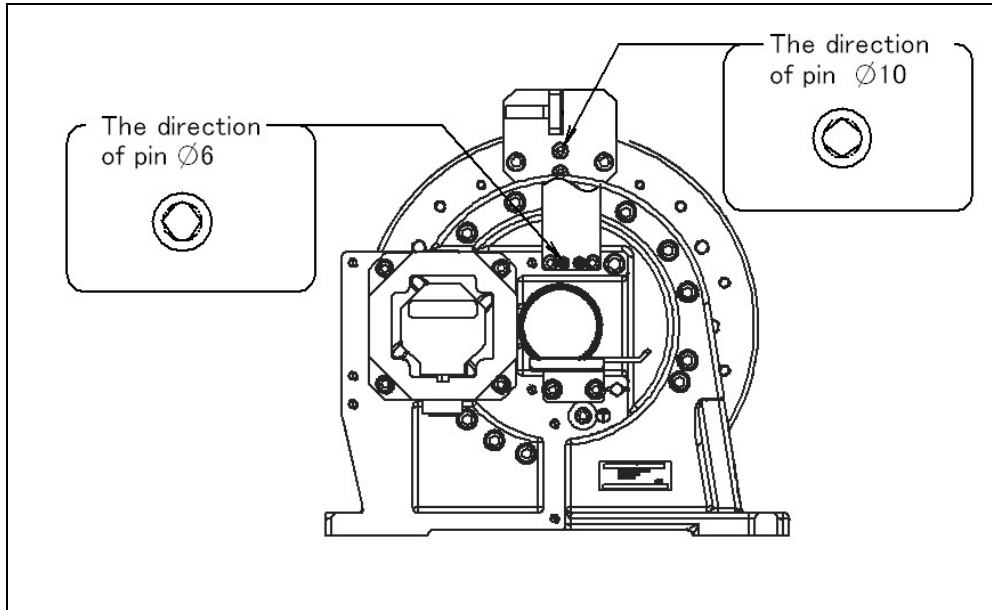

Fig. 5.2.2 (b) Attaching the mastering fixture to the 1-axis positioner (300kg payload (hollow type)), (300kg/500kg payload (Hollow type))

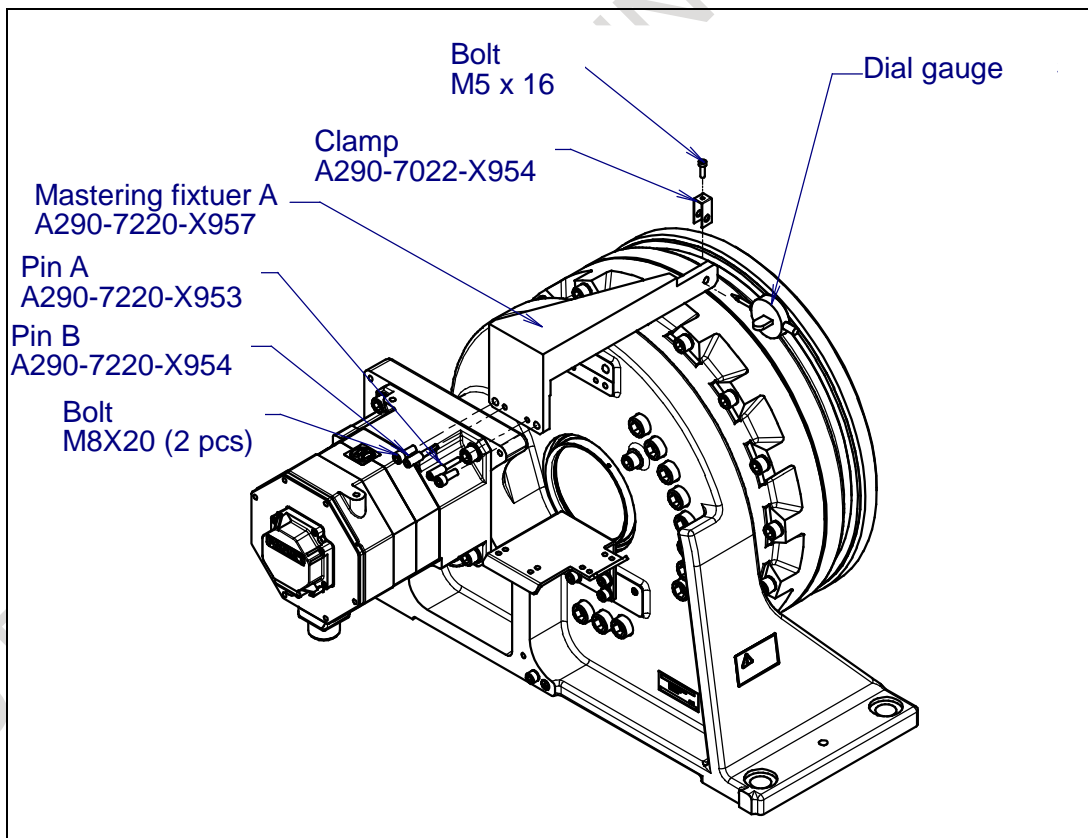

Fig. 5.2.2 (c) Attaching the mastering fixture to the 1-axis positioner (1000kg/1500kg payload (Hollow type))

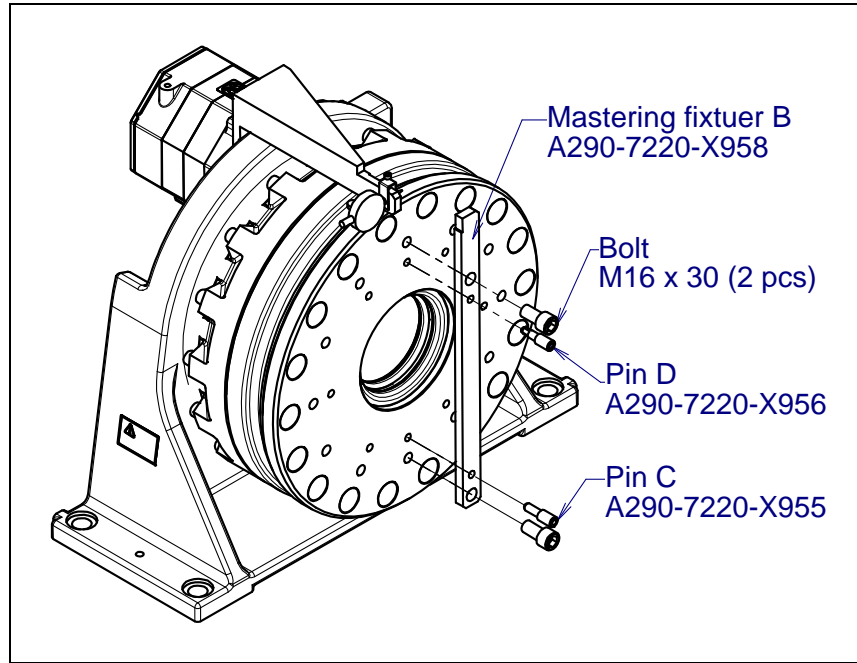

Fig. 5.2.2 (d) Attaching the mastering fixture to the 1-axis positioner (1000kg/1500kg payload (Hollow type))

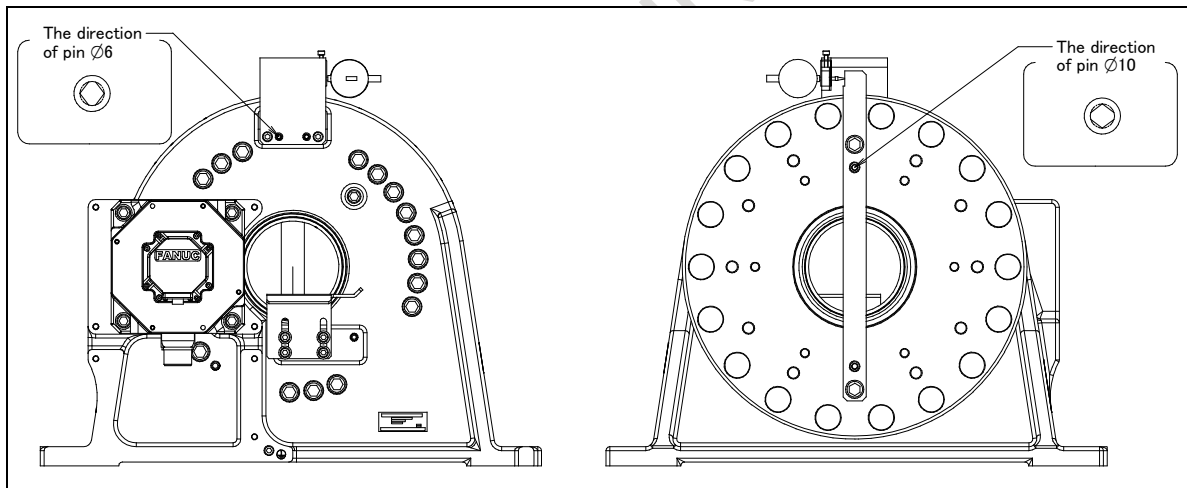

Fig. 5.2.2 (e) Attaching the mastering fixture to the 1-axis positioner (1000kg/1500kg payload (Hollow type))

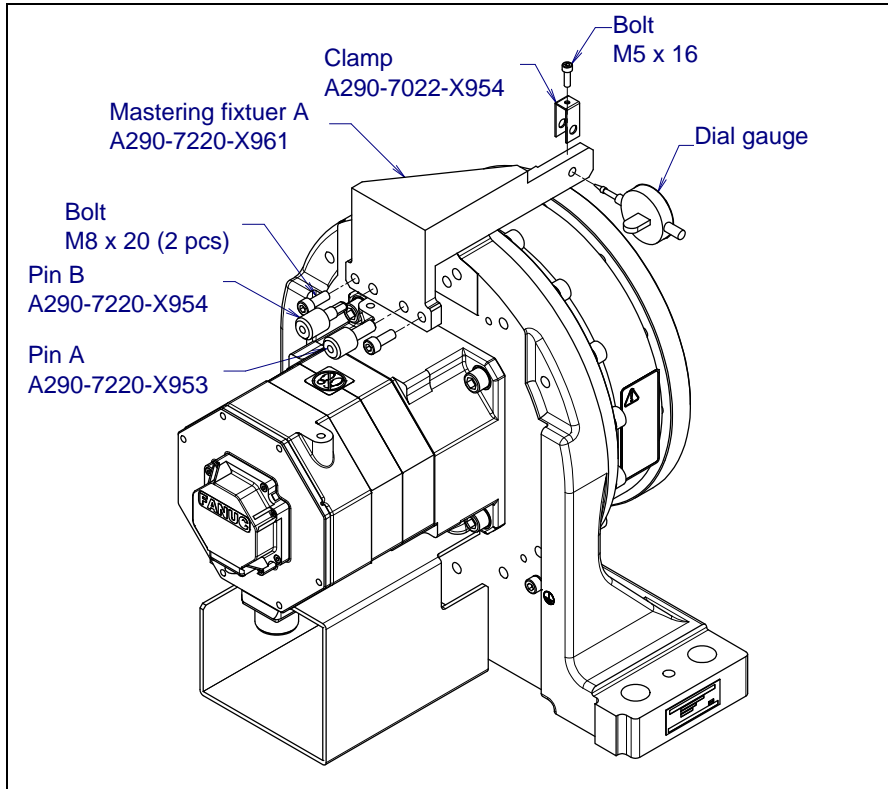

Fig. 5.2.2 (f) Attaching the mastering fixture to the 1-axis positioner (1000kg/1500kg payload (Compact type))

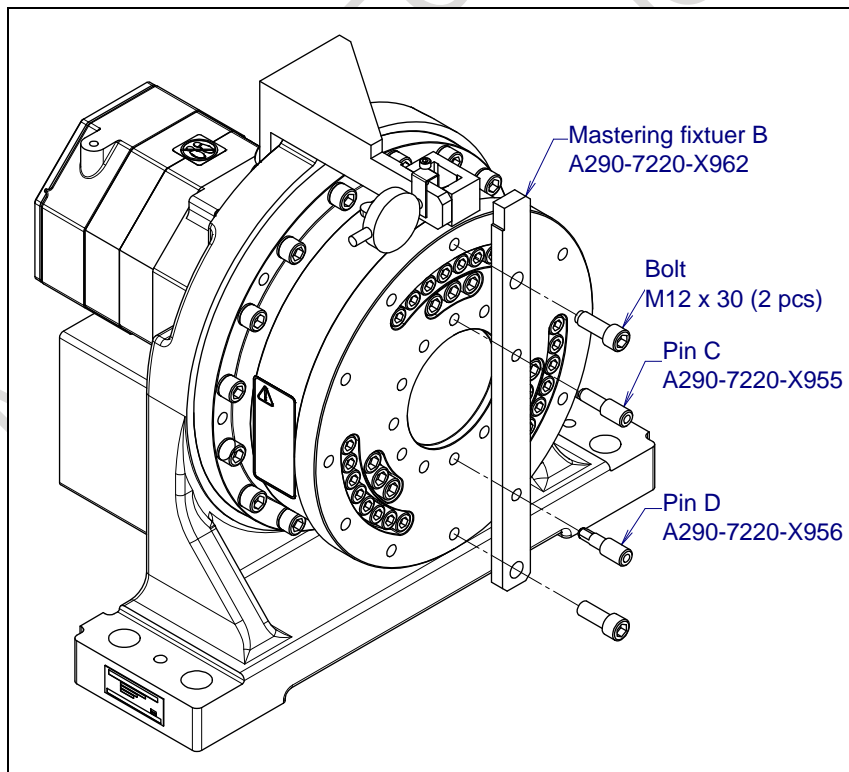

Fig. 5.2.2 (g) Attaching the mastering fixture to the 1-axis positioner (1000kg/1500kg payload (Compact type))

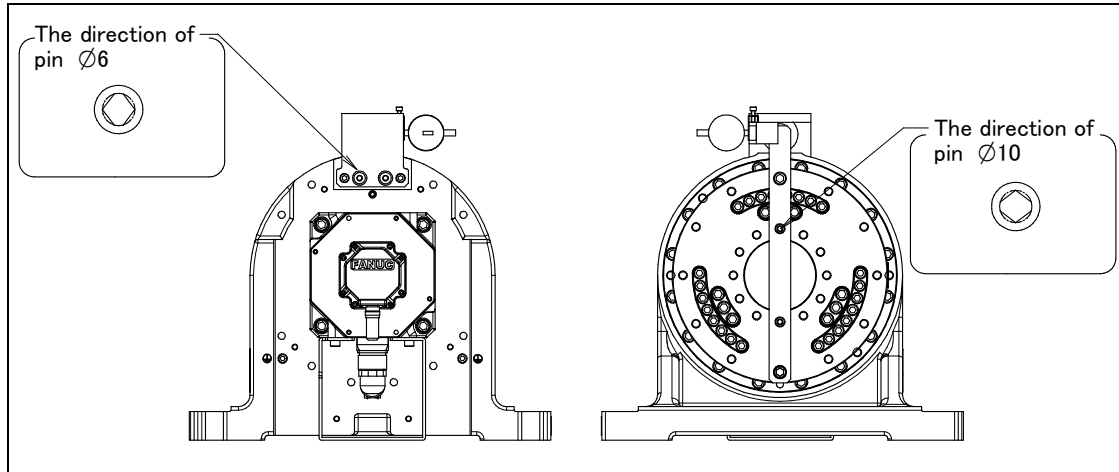
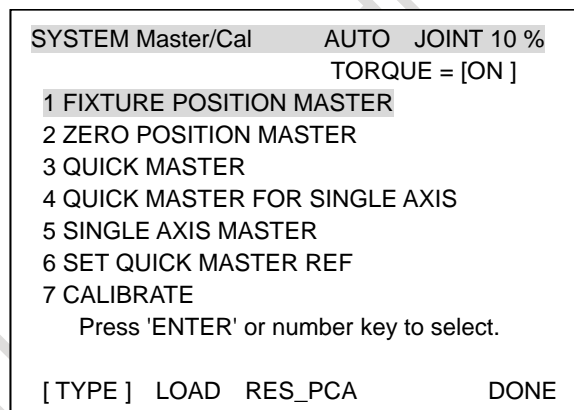

Fig. 5.2.2 (h) Attaching the mastering fixture to the 1-axis positioner (1000kg/1500kg payload (Compact type))

Mastering

- 1 Press the [MENU] key.
- 2 Press NEXT and select [6 SYSTEM].
- 3 Press F1, [TYPE].
- 4 Select Master/Cal.



- 5 Release brake control, and jog the positioner into a posture for mastering. See fig. 5.2.2 (i) to (k) for the mastering posture.

NOTE

Brake control can be released by setting the system variables as follows:

\$PARAM_GROUP.(*)SSV_OFF_ALL: FALSE

\$PARAM_GROUP.(*)SSV_OFF_ENB[*]: FALSE (for all axes)

After changing the system variables, turn off the controller power and on again.

(*) is the axis number of the positioner.

Slowly move the positioner by axial feed so that the values of dial indicators shown in Fig. 5.2.2 (i) to (k) is 3 mm.

- 10 After mastering, update the mastering data listed in the factory-supplied data sheet with new mastering data (\$DMR_GROUP.\$MASTER_COUN [*]).
[*] is the axis number of the positioner.).

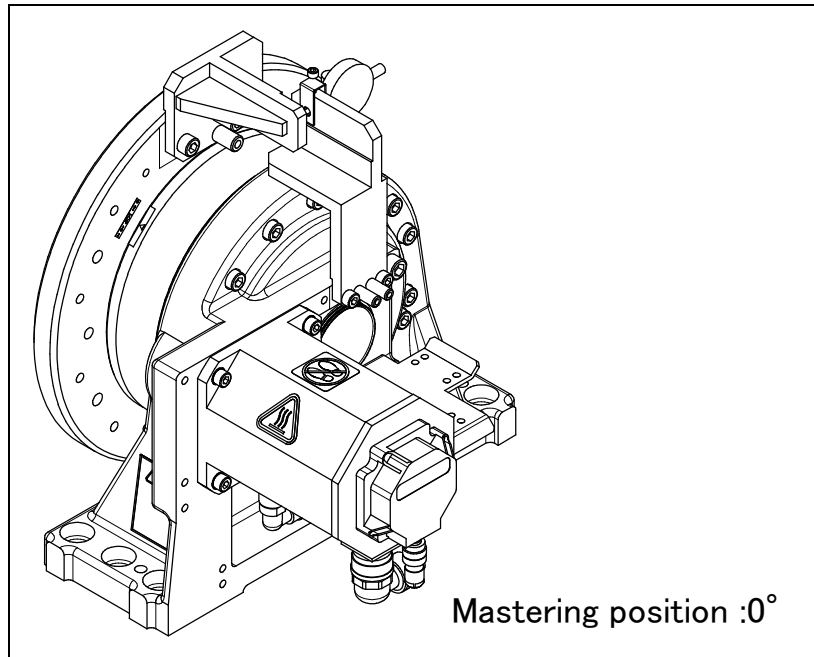

**Fig. 5.2.2 (i) Mastering position
(300kg payload (Hollow type)), (300kg/500kg payload (Hollow type))**

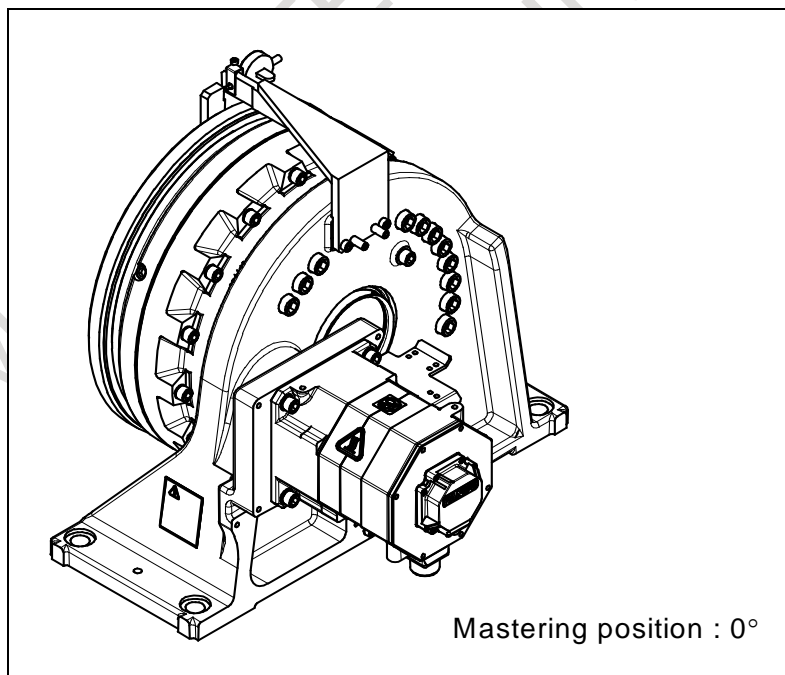

Fig. 5.2.2 (j) Mastering position (1000kg/1500kg payload (Hollow type))

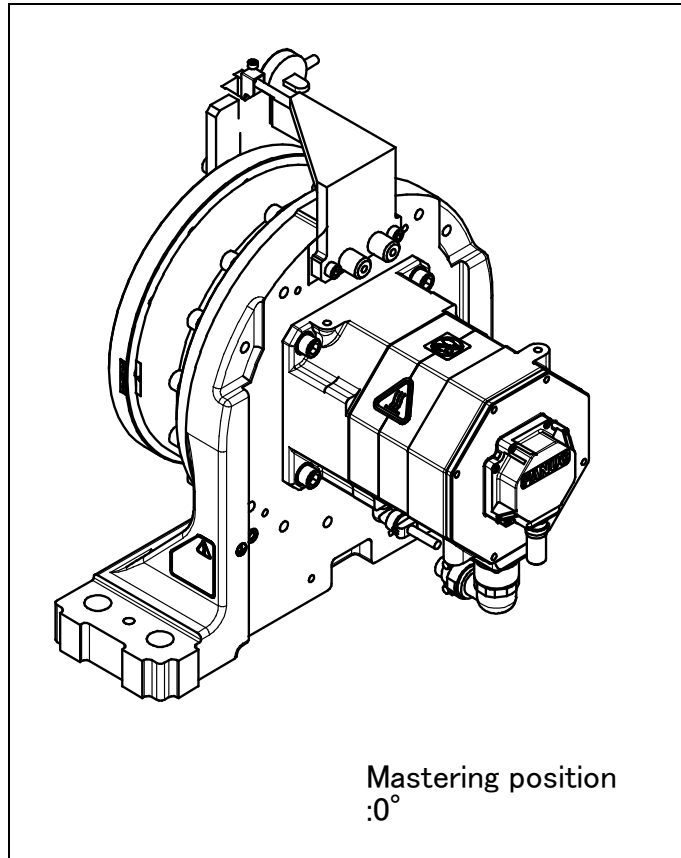

Fig. 5.2.2 (k) Mastering position (1000kg/1500kg payload (Compact type))

5.2.3 Zero Position Mastering

Zero-position mastering is performed with axes set at the 0-degree position. A zero-position mark (witness mark) is attached to each positioner axis. This mastering is performed with all axes set at the 0-degree position using their respective witness marks.

Zero-position mastering involves a visual check. It cannot be so accurate. It should be used only as a quick-fix method.

Zero-position Mastering Procedure

- 1 Press the [MENU] key to display the screen menu.
- 2 Select [0 NEXT] and press [6 SYSTEM].
- 3 Press F1 [TYPE], display the screen change menu.
- 4 Select [Master/Cal]. The positioning screen will be displayed.

```

SYSTEM Master/Cal  AUTO  JOINT 10 %
                    TORQUE = [ON ]
1 FIXTURE POSITION MASTER
2 ZERO POSITION MASTER
3 QUICK MASTER
4 QUICK MASTER FOR SINGLE AXIS
5 SINGLE AXIS MASTER
6 SET QUICK MASTER REF
7 CALIBRATE
  Press 'ENTER' or number key to select.

[ TYPE ]  LOAD  RES_PCA          DONE
  
```

- 5 Release brake control, and jog the robot into a posture for mastering. See Fig. 5.2.3 (a) to (c) for the mastering posture.

NOTE

Brake control can be released by setting the system variables as follows:

\$PARAM_GROUP.SSV_OFF_ALL : FALSE

\$PARAM_GROUP.SSV_OFF_ENB[*] : FALSE

After changing the system variables, turn off the controller power and on again.

([*] is the axis number of the positioner.)

- 6 Select "2 Zero Position Master".

```

SYSTEM Master/Cal  AUTO  JOINT 10 %
                    TORQUE = [ON ]
1 FIXTURE POSITION MASTER
2 ZERO POSITION MASTER
3 QUICK MASTER
4 QUICK MASTER FOR SINGLE AXIS
5 SINGLE AXIS MASTER
6 SET QUICK MASTER REF
7 CALIBRATE
Robot Mastered! Mastering Data:
  <0>

[ TYPE ]  LOAD  RES_PCA          DONE
  
```

- 7 Select [7 CALIBRATE] and press F4, YES. Mastering will be performed automatically. Alternatively, turn the power off and then back on. Mastering is performed. When the power is turned off and then back on, mastering is always performed.

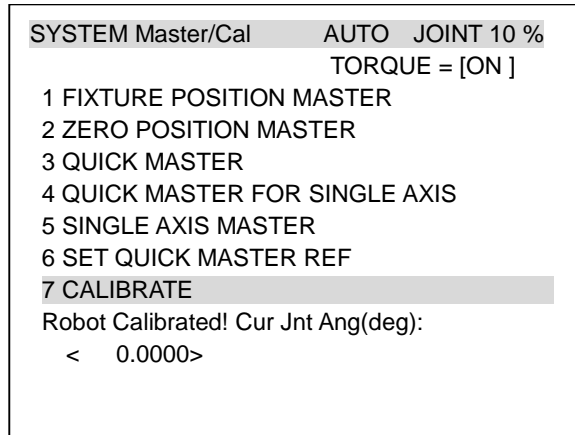

- 8 After calibration is completed, press F5 [DONE].

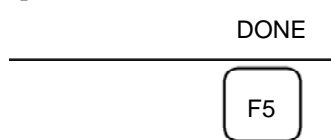

- 9 Reset the brake control release settings to the original state. Set system variables \$PARAM_GROUP, \$SV_OFF_ALL, and \$SV_OFF_ENB to their original values, then turn off then back on the power.

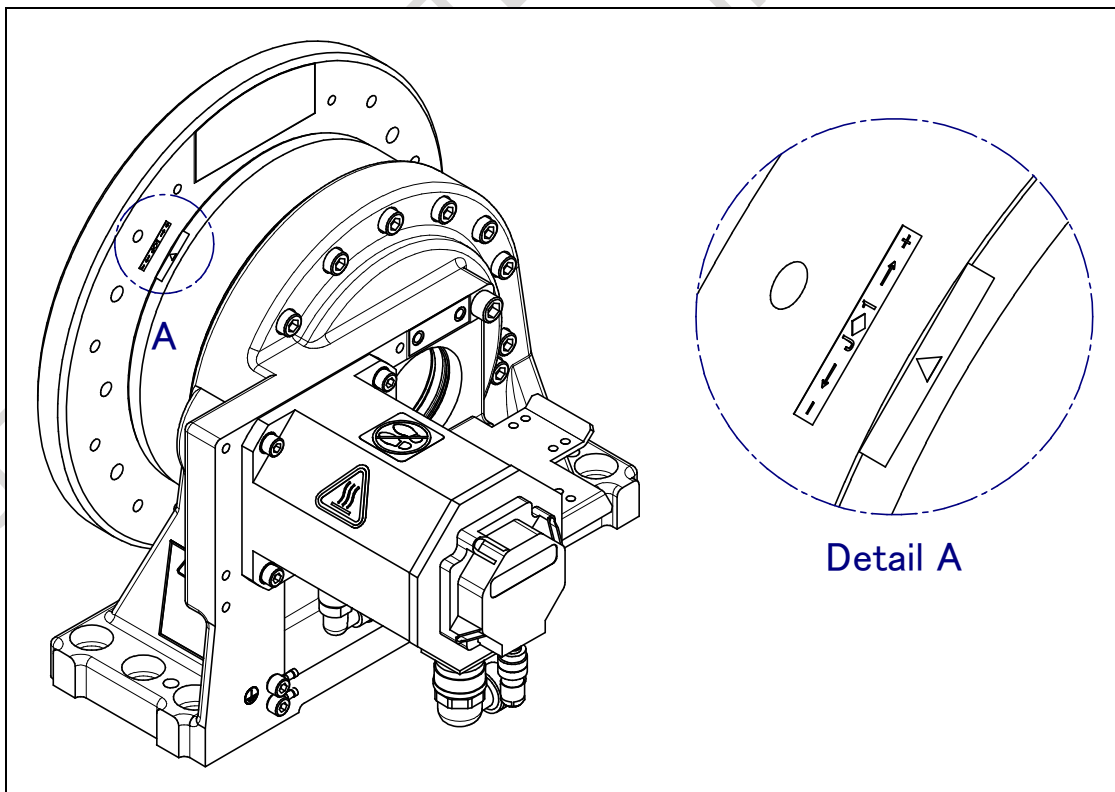

Fig. 5.2.3 (a) Marking of the zero-degree for each axis (witness mark) (300kg payload (Hollow type)), (300kg/500kg payload (Hollow type))

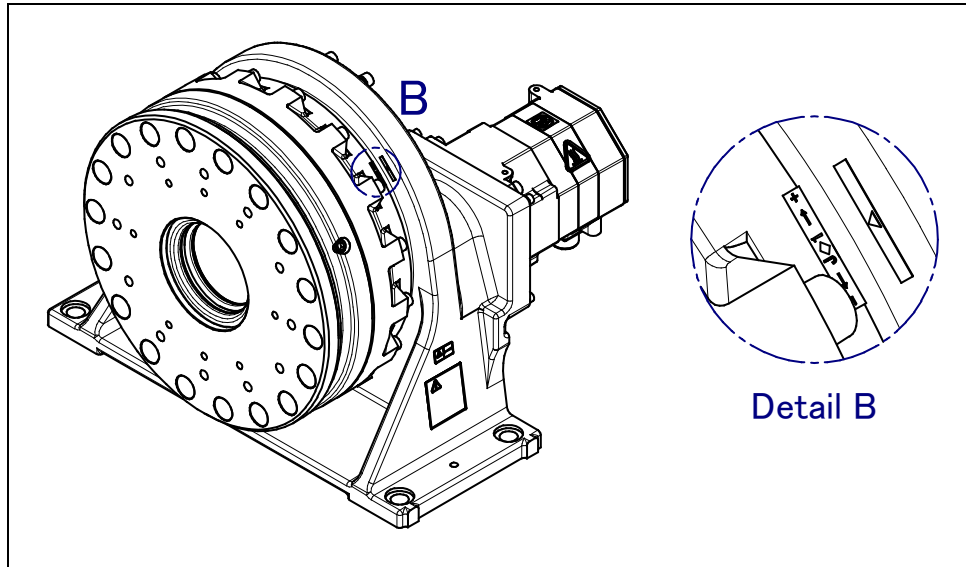

Fig. 5.2.3 (b) Marking of the zero-degree for each axis (witness mark) (1000kg/1500kg payload (Hollow type))

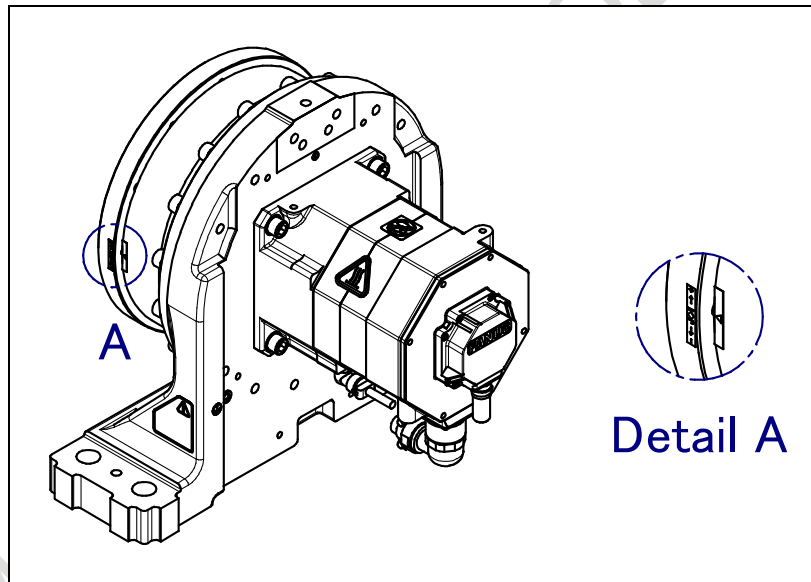

Fig. 5.2.3 (c) Marking of the zero-degree for each axis (witness mark) (1000kg/1500kg payload (Compact type))

5.2.4 Quick Mastering

Quick mastering is performed at a user-specified position for each axis. The pulse count value is obtained from the rotation times of the Pulsecoder connected to the relevant motor and the rotation angle within one rotation. Quick mastering uses the fact that the absolute value of a rotation angle within one rotation will not be lost.

Quick mastering is factory-performed at the zero-degree position. Do not change the setting unless there is a problem.

If it is impossible to set the positioner at the position mentioned above, it is necessary to re-set the quick mastering reference position using the following method. (It would be convenient to set up a marker that can work in place of the position mark.)

⚠ CAUTION

- 1 Quick mastering can be used, if the pulse count value is lost, for example, because a low voltage has been detected on the backup battery for the pulse counter.
- 2 Quick mastering cannot be used, after the Pulsecoder is replaced or after the mastering data is lost from the robot controller.
- 3 This operation cannot be performed if mastering data is lost as a result of mechanical disassembly or maintenance. In this case, perform zero position mastering or fixture position mastering to recover the mastering data.

Procedure for Recording the Quick Master Reference Position

- 1 Select [6 SYSTEM].
- 2 Select [Master/Cal]. The positioning screen will be displayed.

```

SYSTEM Master/Cal  AUTO  JOINT 10 %
                    TORQUE = [ON ]
1 FIXTURE POSITION MASTER
2 ZERO POSITION MASTER
3 QUICK MASTER
4 QUICK MASTER FOR SINGLE AXIS
5 SINGLE AXIS MASTER
6 SET QUICK MASTER REF
7 CALIBRATE
  Press 'ENTER' or number key to select.

[ TYPE ]  LOAD  RES_PCA          DONE
  
```

- 3 Release brake control, and jog the robot to the quick mastering reference position.
- 4 Select "5 SET QUICK MASTER REF" and press F4 [YES]. Quick mastering reference position is saved.

```

5 SINGLE AXIS MASTER
6 SET QUICK MASTER REF
7 CALIBRATE
  
```

F4

⚠ CAUTION

If the robot has lost mastering data due to mechanical disassembly or repair, you cannot perform this procedure. In this case, perform Fixture position mastering or zero –position mastering to restore mastering data.

Procedure Quick Mastering

- 1 Display the Master/Cal screen

```

SYSTEM Master/Cal  AUTO  JOINT 10 %
                    TORQUE = [ON ]
1 FIXTURE POSITION MASTER
2 ZERO POSITION MASTER
3 QUICK MASTER
4 QUICK MASTER FOR SINGLE AXIS
5 SINGLE AXIS MASTER
6 SET QUICK MASTER REF
7 CALIBRATE
  Press 'ENTER' or number key to select.

[ TYPE ]  LOAD  RES_PCA          DONE
  
```

- 2 Release brake control, and jog the robot to the quick mastering reference position.
- 3 Move the cursor to “3 QUICK MASTER” and press the [ENTER] key. Press F4 [YES]. Quick mastering data is memorized.

```

2 ZERO POSITION MASTER
3 QUICK MASTER
4 QUICK MASTER FOR SINGLE AXIS
  
```

F4

- 4 Move the cursor to [7 CALIBRATE] and press the [ENTER] key. Calibration is executed. Calibration can also be executed by cycling power.
- 5 After completing the calibration, press F5 Done.

DONE

F5

- 6 Restore brake control. Reset system variables \$PARAM_GROUP.\$SV_OFF_ALL and \$PARAM_GROUP.\$SV_OFF_ENB to their original values, and turn the power off and then back on.
- 7 After mastering, update the mastering data listed in the factory-supplied data sheet with new mastering data (\$DMR_GROUP [*].\$MASTER_COUN).
([*] is the group number of the positioner.)

5.2.5 QUICK MASTERING FOR SINGLE AXIS

Quick mastering for a single axis is performed at a user-specified position for one axis. The pulse count value is obtained from the rotation times of the Pulsecoder connected to the relevant motor and the rotation angle within one rotation. Quick mastering uses the fact that the absolute value of a rotation angle within one rotation will not be lost.

Quick mastering is factory-performed at the zero-position. Do not change the setting unless there is any problem.

If setting the robot at the position mentioned above is impossible, you must re-set the quick mastering reference position using the following method. (It would be convenient to set up a marker that can work in place of the witness mark.)

⚠ CAUTION

- 1 Quick mastering can be used, if the pulse count value is lost, for example, because a low voltage has been detected on the backup battery for the pulse counter.
- 2 Quick mastering cannot be used, after the Pulsecoder is replaced or after the mastering data is lost from the robot controller.

Procedure for Recording the Quick Mastering Reference Position

- 1 Select [6 SYSTEM].
- 2 Select [Master/Cal]. The positioning screen will be displayed.

```

SYSTEM Master/Cal  AUTO  JOINT 10 %
                TORQUE = [ON ]
1 FIXTURE POSITION MASTER
2 ZERO POSITION MASTER
3 QUICK MASTER
4 QUICK MASTER FOR SINGLE AXIS
5 SINGLE AXIS MASTER
6 SET QUICK MASTER REF
7 CALIBRATE
  Press 'ENTER' or number key to select.

[ TYPE ]  LOAD  RES_PCA          DONE
  
```

- 3 Release brake control, and jog the robot to the quick mastering reference position.
- 4 Select "6 SET QUICK MASTER REF" and press F4 [YES]. Quick mastering reference position will be set.

```

5 SINGLE AXIS MASTER
6 SET QUICK MASTER REF
7 CALIBRATE
  
```

F4

⚠ CAUTION

If the robot has lost mastering data due to mechanical disassembly or repair, you cannot perform this procedure. In this case, perform Fixture position mastering or zero –position mastering to restore mastering data.

Procedure of Quick Mastering for single axis

- 1 Display the Master/Cal screen.

SYSTEM Master/Cal	AUTO	JOINT 10 %
TORQUE = [ON]		
1 FIXTURE POSITION MASTER		
2 ZERO POSITION MASTER		
3 QUICK MASTER		
4 QUICK MASTER FOR SINGLE AXIS		
5 SINGLE AXIS MASTER		
6 SET QUICK MASTER REF		
7 CALIBRATE		
Robot Not Mastered!		
Quick master? [NO]		

- 2 Select "4 QUICK MASTER FOR SINGLE AXIS". You will see the quick master for single axis screen.

SINGLE AXIS MASTER		AUTO	JOINT 10%
			1/9
	ACTUAL POS	(MSTR POS)	(SEL) [ST]
J1	0.000	(0.000)	(0) [2]
J2	0.000	(0.000)	(0) [2]
J3	0.000	(0.000)	(0) [2]
J4	0.000	(0.000)	(0) [2]
J5	0.000	(0.000)	(0) [2]
J6	0.000	(0.000)	(0) [0]
E1	0.000	(0.000)	(0) [0]
E2	0.000	(0.000)	(0) [0]
E3	0.000	(0.000)	(0) [0]
EXEC			

- 3 Move the cursor to the [SEL] column for the unmastered axis and press the numeric key [1]. Setting of [SEL] is available for one or more axes.

SINGLE AXIS MASTER		AUTO	JOINT 10%
			1/9
	ACTUAL POS	(MSTR POS)	(SEL) [ST]
J1	0.000	(0.000)	(0) [2]
J2	0.000	(0.000)	(0) [2]
EXEC			

- 4 Turn off brake control, then jog the robot to the quick mastering reference position.
- 5 Press F5 [EXEC]. Mastering is performed. So, [SEL] is reset to 0, and [ST] is re-set to 2.
- 6 Move the cursor to "7 CALIBRATE" and press the [ENTER] key. Calibration is executed. Calibration may also be executed by cycling power.
- 7 After completing the calibration, press F5 Done.

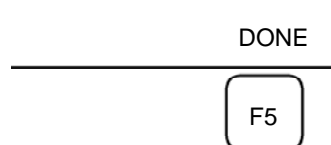

- 8 Return brake control to original setting, and cycle power of the controller.

5.2.6 Single Axis Mastering

Single axis mastering is performed for one axis at a time. The mastering position for each axis can be specified by the user.

Single axis mastering can be used, if mastering data for a specific axis is lost, for example, because a low voltage has been detected on the pulse counter backup battery or because the Pulsecoder has been replaced.

SINGLE AXIS MASTER		AUTO	JOINT 10%
	ACTUAL POS	(MSTR POS)	(SEL) [ST]
J1	0.000	(0.000)	(0) [2]
J2	0.000	(0.000)	(0) [2]
J3	0.000	(0.000)	(0) [2]
J4	0.000	(0.000)	(0) [2]
J5	0.000	(0.000)	(0) [2]
J6	0.000	(0.000)	(0) [0]
E1	0.000	(0.000)	(0) [0]
E2	0.000	(0.000)	(0) [0]
E3	0.000	(0.000)	(0) [0]
EXEC			

Table 5.2.6 Items set in single axis mastering

Item	Description
Current position (ACTUAL AXIS)	The current position of the robot is displayed for each axis in degree units.
Mastering position (MSTR POS)	A mastering position is specified for an axis to be subjected to single axis mastering. It would be convenient if it is set to 0 degree position.
SEL	This item is set to 1 for an axis to be subjected to single axis mastering. Usually, it is 0.
ST	This item indicates whether single axis mastering has been completed for the corresponding axis. It cannot be changed directly by the user. The value of the item is reflected in \$EACHMST_DON (1 to 9). 0 : Mastering data has been lost. Single axis mastering is necessary. 1 : Mastering data has been lost. (Mastering has been performed only for the other interactive axes.) Single axis mastering is necessary. 2 : Mastering has been completed.

Procedure of Single axis mastering

- 1 Select [6 SYSTEM].
- 2 Select [Master/Cal]. The positioning screen will be displayed.

SYSTEM Master/Cal	AUTO	JOINT 10 %
TORQUE = [ON]		
1 FIXTURE POSITION MASTER		
2 ZERO POSITION MASTER		
3 QUICK MASTER		
4 QUICK MASTER FOR SINGLE AXIS		
5 SINGLE AXIS MASTER		
6 SET QUICK MASTER REF		
7 CALIBRATE		
Press 'ENTER' or number key to select.		
[TYPE]	LOAD	RES_PCA DONE

- 3 Select “5 SINGLE AXIS MASTER”. The following screen will be displayed.

SINGLE AXIS MASTER		AUTO	JOINT 10%
			1/9
ACTUAL	POS	(MSTR POS)	(SEL) [ST]
J1	0.000	(0.000)	(0) [2]
J2	0.000	(0.000)	(0) [2]
J3	0.000	(0.000)	(0) [2]
J4	0.000	(0.000)	(0) [2]
J5	0.000	(0.000)	(0) [2]
J6	0.000	(0.000)	(0) [0]
E1	0.000	(0.000)	(0) [0]
E2	0.000	(0.000)	(0) [0]
E3	0.000	(0.000)	(0) [0]
EXEC			

- 4 For the axis to which to perform single axis mastering, set (SEL) to “1.” Setting of [SEL] is available for one or more axes.
- 5 Turn off brake control, then jog the robot to the mastering position.
- 6 Enter axis data for the mastering position.
- 7 Press F5 [EXEC]. Mastering is performed. So, [SEL] is reset to 0, and [ST] is re-set to 2 or 1.



SINGLE AXIS MASTER		AUTO	JOINT 10%
			6/9
ACTUAL	POS	(MSTR POS)	(SEL) [ST]
J1	0.000	(0.000)	(0) [2]
J2	0.000	(0.000)	(0) [2]
J3	0.000	(0.000)	(0) [2]
J4	0.000	(0.000)	(0) [2]
J5	0.000	(0.000)	(0) [2]
J6	90.000	(0.000)	(1) [0]
E1	0.000	(0.000)	(0) [0]
E2	0.000	(0.000)	(0) [0]
E3	0.000	(0.000)	(0) [0]
EXEC			

5.2.7 Mastering Data Entry

This function enables mastering data values to be assigned directly to a system variable. It can be used if mastering data has been lost but the pulse count is preserved.

Mastering data entry method

- 1 Press the [MENU] key, then select the [6 SYSTEM].
- 2 Press F1 [TYPE]. Select [Variables]. The system variable screen will be displayed.

SYSTEM Variables		AUTO	JOINT 10%
			1/669
1	\$AAVM_GRP	AAVM_GRP_T	
2	\$AAVM_WRK	AAVM_WRK_T	
3	\$ABSPOS_GRP	ABSPOS_GRP_T	
4	\$ACC_MAXLMT	0	
5	\$ACC_MINLMT	0	
6	\$ACC_PRE_EXE	0	
[TYPE] DETAIL			

- 3 Change the mastering data.
The mastering data is saved to the \$DMR_GRP.\$MASTER_COUN system variable.

SYSTEM Variables		AUTO	JOINT 10%
			1/669
135	\$DMR_GRP	DMR_GRP_T	
136	\$DMSW_CFG	DMSW_CFG_T	
[TYPE]			

- 4 Select \$DMR_GRP.

SYSTEM Variables		AUTO	JOINT 10%
\$DMR_GRP			1/1
1	[1]	DMR_GRP_T	
[TYPE] DETAIL			

SYSTEM Variables		AUTO	JOINT 10%
\$DMR_GRP			1/29
1	\$MASTER_DONE	FALSE	
2	\$OT_MINUS	[9] of BOOLEAN	
3	\$OT_PLUS	[9] of BOOLEAN	
4	\$MASTER_COUN	[9] of INTEGER	
5	\$REF_DONE	FALSE	
6	\$REF_POS	[9] of REAL	
[TYPE]		TRUE	FALSE

- 5 Select \$MASTER_COUN, and enter the mastering data you have recorded.

SYSTEM Variables		AUTO	JOINT 10%
\$DMR_GRP[1].\$MASTER_COUN			1/9
1	[1]	95678329	
2	[2]	10223045	
3	[3]	3020442	
4	[4]	30405503	
5	[5]	20497709	
6	[6]	2039490	
7	[7]	0	
8	[8]	0	
9	[9]	0	
[TYPE]			

- 6 Press the [PREV] key.
- 7 Set \$MASTER_DONE to TRUE.

SYSTEM Variables		AUTO	JOINT 10%
\$DMR_GRP			1/29
1	\$MASTER_DONE	TRUE	
2	\$OT_MINUS	[9] of BOOLEAN	
[TYPE]		TRUE	FALSE

- 8 Display the positioning screen, and select "7 CALIBRATE", then press F4 [YES].
- 9 After completing positioning, press F5 [DONE].

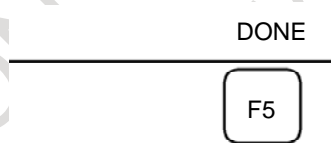

5.2.8 VERIFYING MASTERING

1 How to verify that the robot is mastered properly:

Usually, positioning is performed automatically when the power is turned on. To check whether mastering has been performed correctly, examine if the current displayed position matches the actual robot position by using one or more of the procedures described below:

- (1) Reproduce a particular point in a program. Check whether the point agrees with the specified position.
- (2) Set all axes of the robot to their 0-degree (0 rad) positions. Check that the zero-degree position marks indicated in Subsection 5.2.3 is aligned. There is no need to use a visual aid.
- (3) Using fixtures, set the robot to the mastering position in the same way as when performing mastering. Check that the displayed current position agrees with the actual mastering position.

If the displayed and actual positions do not match, the counter value for a Pulsecoder may have been invalidated as a result of an alarm described in 2. Alternatively, the mastering data in system variable \$DMR_GRP.\$MASTER_COUN may have been overwritten as a result of an operation error or some other reason.

Compare the data with the values indicated on the supplied data sheet. This system variable is overwritten whenever mastering is performed. Whenever mastering is performed, record the value of the system variable on the data sheet.

2 Alarm types displayed during mastering and their solution method:

(1) BZAL alarm

This alarm is displayed if the Pulsecoder's backup battery voltage decreases to 0 V while the power to the controller is disconnected. Furthermore, if the Pulsecoder connector is removed for cable replacement, etc. this alarm is displayed as the voltage decreases to 0. Check to see if the alarm will disappear by performing a pulse reset (See Subsection 5.2.2). Then, cycle controller power and check if the alarm disappears or not.

The battery may be drained if the alarm is still displayed. Perform a pulse reset, and turn off and on the controller power after replacing the battery. Note that, if this alarm is displayed, all the original data held by the Pulsecoder will be lost. Mastering is required.

(2) BLAL alarm

This alarm is displayed if the voltage of the Pulsecoder's backup battery has fallen to a level where backup is no longer possible. If this alarm is displayed, replace the battery with a new one immediately while keeping the power turned on. Check whether the current position data is valid, using the procedure described in 1.

(3) Alarm notification like CKAL, RCAL, PHAL, CSAL, DTERR, CRCERR, STBERR, and SPHAL may have trouble with Pulsecoder, contact your local FANUC representative.

6 REPLACING PARTS

Once motors, reducers, and gears are replaced, mastering becomes necessary, Perform mastering according to Chapter 5 of MAINTENANCE after any of these components is replaced.

NOTE

Be very careful when dismantling and mounting the heavy components that are listed below.

Component	Weight (about)	Load capacity
Motor	10kg	300kg payload (Hollow type) 300kg/500kg payload (Hollow type)
Motor	22kg	1000kg/1500kg payload (Hollow type) 1000kg/1500kg payload (Compact type)
Reducer	20kg	300kg payload (Hollow type) 300kg/500kg payload (Hollow type)
Reducer	91kg	1000kg/1500kg payload (Hollow type)
Reducer	45kg	1000kg/1500kg payload (Compact type)
Flange	16kg	300kg payload (Hollow type) 300kg/500kg payload (Hollow type)
Flange	28kg	1000kg/1500kg payload (Hollow type)
Flange	9kg	1000kg/1500kg payload (Compact type)
Ground brush	5kg	300kg/500kg payload (Hollow type) For Infinite continuous turn mechanical option (A05B-1220-J117)

NOTE

When applying LOCTITE to a part, spread the LOCTITE on the entire length area of the engaging part of the female thread. If applied to the male threads, poor adhesion can occur potentially loosening the bolt. Clean the bolts and the threaded holes and wipe off the oil on the engaging section. Make sure that there is no solvent left in the threaded holes. In this case, remove all the excess LOCTITE when you are finished screwing the bolts into the threaded holes.

6.1 REPLACING THE MOTOR

6.1.1 In the case of 300kg payload (Hollow type), 300kg/500kg payload (Hollow type)

- 1 Set dial gauges, and prepare for single axis mastering after replacement.
- 2 Turn off controller power.
- 3 Remove the bolts (1) and remove the motor cover (2). (When the HARTING connector option or motor cover options is specified.)
- 4 After removing the battery box fixing plate while referencing Fig. 6.1.1 (b), remove the four M6 x 10 bolts and remove the connector box.
(Only when the HARTING connector option is selected)
- 5 Remove the motor connector.
- 6 Remove the bolts (3), washers (4), and remove the motor (5).
- 7 Attach the gear (9) to a new motor, and reverse the removal steps to mount the motor. Replace the O-ring (6) with new ones, and put the new O-rings in place. See Fig. 6.1.1 (a) below table for the tightening torque and LOCTITE application.
- 8 Supply the reducer with the specified grease as described in Section 3.1.
- 9 Perform single axis mastering as described in Subsection 5.2.5 of MAINTENANCE.

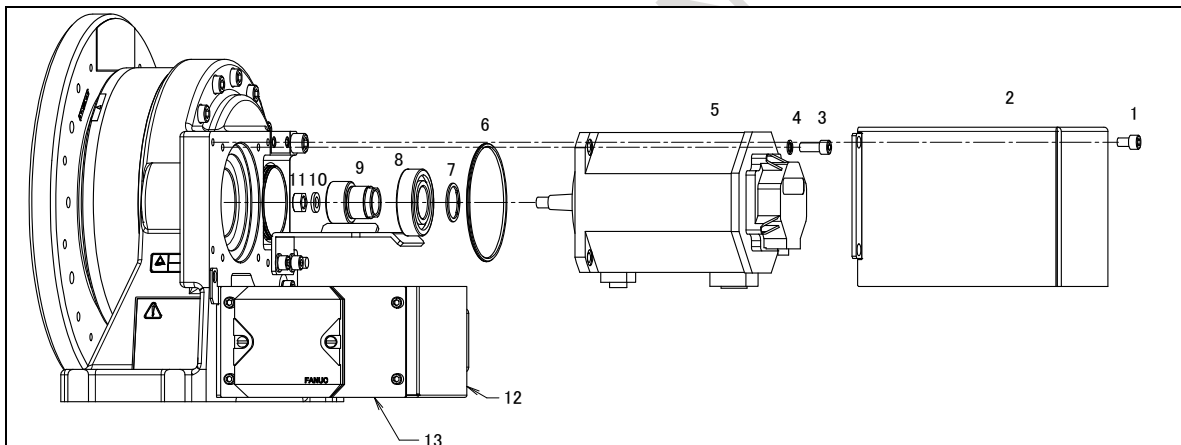

Fig. 6.1.1 (a) Replacing the motor
(300kg payload (Hollow type)), (300kg/500kg payload (Hollow type))

	Parts name	Specifications	Q'ty	Locking	Torque N-m
1	BOLT (*1)(*2)	A6-BA-8X12	4		
2	COVER (*1)(*2)	A290-7220-X121	1		
3	BOLT	A6-BA-8X20	4		
4	WASHER	A97L-0001-0823#M8H	4		
5	MOTOR (NOTE 1)	A06B-0235-B605#S000 (*5) A06B-2235-B605 (*6)	1		
6	O-RING	JB-OR1A-G105	1		
7	C RING	A97L-0118-0520#GV-30	1		
8	BEARING	A97L-0001-0195#0600000 (*3) A97L-0218-0903#6306R (*4)	1		
9	GEAR	A290-7220-X111 (*3) A290-7220-Z111 (*4)	1		
10	WASHER	Motor appendix	1		
11	NUT	Motor appendix	1	LT243	16.7
12	CONNECTOR BOX (*1)	A290-7220-X122	1		
13	PLATE (*1)	A290-7220-X123	1		

(*1) When the HARTING connector option is specified

(*2) When the motor cover option is specified

(*3) 300kg payload (Hollow type)

(*4) 300kg/500kg payload (Hollow type)

NOTE

- 1 Both motors (*5) (*6) can be used. However, we recommend (*6) when ordering motors.
- 2 Replace the oil seal only when it is broken.

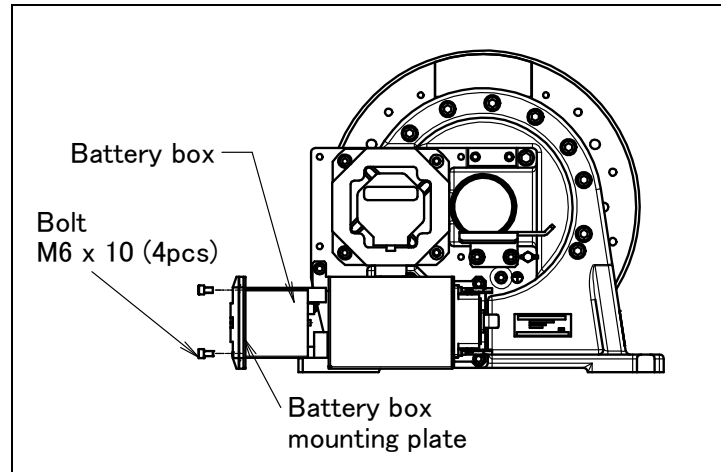

Fig. 6.1.1 (b) Removing the connector box (when the HARTING connector option is selected)

6.1.2 In the case of 1000kg/1500kg payload (Hollow type)

- 1 Set dial gauges, and prepare for single axis mastering after replacement.
- 2 Turn off controller power.
- 3 Remove the bolts (1) and remove the motor cover (2). (When the HARTING connector option or motor cover options is specified.)
- 4 After removing the battery box fixing plate while referencing Fig. 6.1.1 (b), remove the four M6 x 10 bolts and remove the connector box.
(Only when the HARTING connector option is selected)
- 5 Remove the motor connector.
- 6 Remove the motor mounting bolts (3) and washers (4), and remove the motor (5).
- 7 Attach the gear to a new motor, and reverse the removal steps to mount the motor. Replace the O-rings with new ones, and put the new O-ring (6) in place. See Fig. 6.1.2 below table for the tightening torque and LOCTITE application.
- 8 Supply the reducer with the specified grease as described in Section 3.1.
- 9 Perform single axis mastering as described in Subsection 5.2.5 of MAINTENANCE.

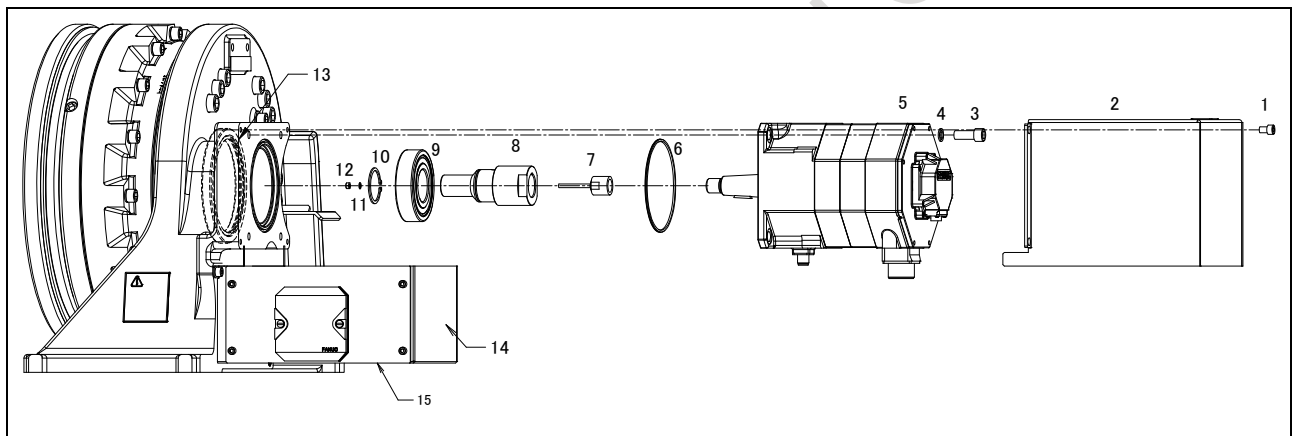

Fig. 6.1.2 Replacing the motor (1000kg/1500kg payload (Hollow type))

	Parts name	Specifications	Q'ty	Locking	Torque N-m
1	BOLT (*1)(*2)	A6-BA-8X12	4		
2	COVER (*1)(*2)	A290-7220-X124	1		
3	BOLT	A6-BA-12X30	4		
4	WASHER	A97L-0001-0823#M12H	4		
5	MOTOR	A06B-0265-B605#S000	1		
6	O-RING	JB-OR1A-G125	1		
7	DRAW BOLT	Reducer appendix	1	LT243	118Nm
8	GEAR	Reducer appendix	1		
9	BEARING	A97L-0001-0196#09Z000A	1		
10	C RING	A6-CJR-45	1		
11	WASHER	A97L-0001-0823#M5H	1		
12	NUT	A6-N1-5S	1	LT243	3.2
13	OIL SEAL	A98L-0040-0047#13016014	1		
14	CONNECTOR BOX (*1)	A290-7220-X122	1		
15	PLATE (*1)	A290-7220-X123	1		

(*1) When the HARTING connector option is specified

(*2) When the motor cover option is specified

NOTE

Replace the bearing or the oil seal only when it is broken.

6.1.3 In the case of 1000 kg/1500kg payload (Compact type)

- 1 Set dial gauges, and prepare for single axis mastering after replacement.
- 2 Turn off controller power.
- 3 Remove the bolts (1) and remove the motor cover (2). (When the HARTING connector option or motor cover options is specified.)
- 4 Remove the motor connector.
- 5 Remove the bolts (4), washers (5), and remove the motor (6).
- 6 Attach the gear (8) to a new motor, and reverse the removal steps to mount the motor. Replace the O-rings (10) with new ones, and put the new O-rings in place. See Table below the Fig. 6.1.3 for the tightening torque and LOCTITE application.
- 7 Supply the reducer with the specified grease as described in Section 3.1.
- 8 Perform single axis mastering as described in Subsection 5.2.6 of MAINTENANCE.

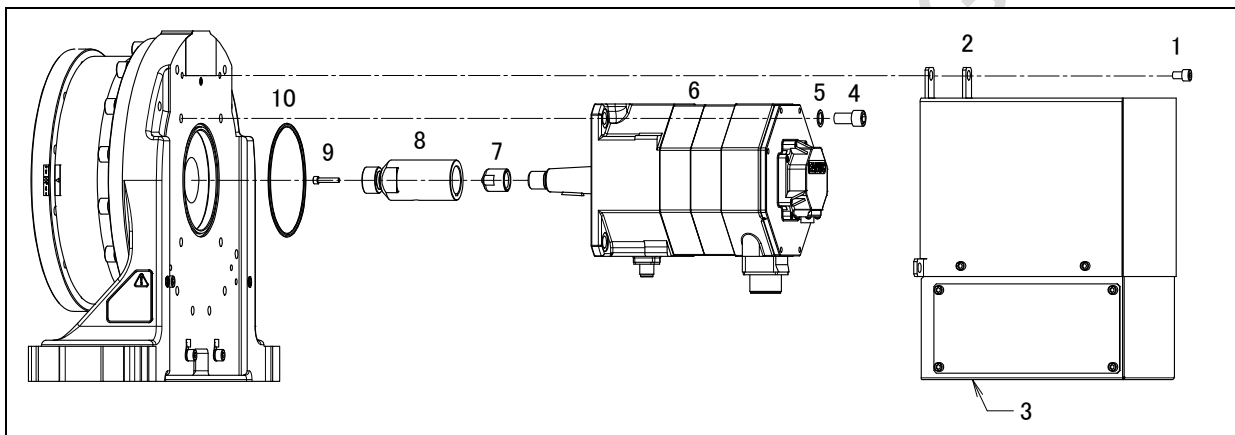

Fig. 6.1.3 Replacing the motor (1000kg/1500kg payload (Compact type))

	Parts name	Specifications	Q'ty	Locking	Torque N-m
1	BOLT (*1) (*2)	A6-BA-8X12	4		
2	COVER (*1) (*2)	A290-7220-X127	1		
3	CONNECTOR BOX (*1)	A290-7220-X128	1		
4	SEAL BOLT	A97L-0218-0423#122210	4		
5	WASHER	A290-7220-X155	4		
6	MOTOR	A06B-0265-B605#S000	1		
7	DRAW NUT	A290-7220-X153	1	LT243	118
8	GEAR	A290-7220-X151	1		
9	BOLT	A6-BA-5X25	1	LT243	3.2
10	O-RING	JB-OR1A-125	1		

(*1) When the HARTING connector option is specified

(*2) When the motor cover option is specified

6.2 REPLACING THE REDUCER

6.2.1 In the case of 300kg payload (Hollow type), 300kg/500kg payload (Hollow type)

- 1 Set dial gauges, and prepare for single axis mastering after replacement.
- 2 Remove the motor as Section 6.1.
- 3 Remove the covers (1), bolts (2), washer plates (3), insulators A (5) and B (6), collar (4), flange (7), and insulator (6) in that order.
- 4 Pull the pipe (9) out of the reducer (11).
- 5 Remove the bolts (15) and washers (14) that fasten the reducer on the base, and remove the reducer (11).
- 6 Remove the gear.
- 7 Reverse the removal steps to mount a new reducer. Replace the O rings (8) with new ones, and put the new O rings in place. Be careful not to damage the oil seal. Install the collar (4) after installing the insulator A (5) See Fig. 6.2.1 below table for the tightening torque and LOCTITE application.
- 8 Mount the motor as Section 6.1.
- 9 Supply the reducer with the specified grease as described in Section 3.1.
- 10 Perform single axis mastering as described in Subsection 5.2.5 of MAINTENANCE.

NOTE

When the influence of the damaged pieces generated from broken reducer is concerned about, exchange gear of the J1-axis motor shaft and center gear of the reducer.

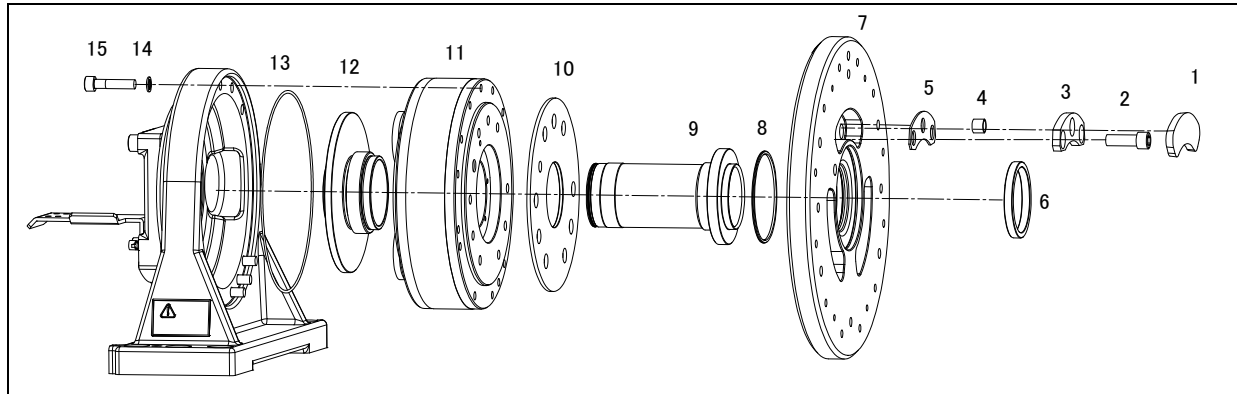

Fig. 6.2.1 Replacing the reducer (300kg payload (Hollow type)), (300kg/500kg payload (Hollow type))

300kg payload (Hollow type)

	Parts name	Specifications	Q'ty	Locking	Torque N-m
1	COVER	A290-7220-X326	3		
2	BOLT	A6-BA-12X35	9	LT263	128.4
3	WASHER PLATE	A290-7220-X324	3		
4	COLLAR	A98L-0040-0211#121512	9		
5	INSULATOR A	A290-7220-X325	3		
6	INSULATOR B	A290-7220-X328	1		
7	FLANGE	A290-7220-X112	1		
8	O-RING	JB-OR1A-G95	1		
9	PIPE	A290-7220-X321	1		
10	INSULATOR C	A290-7220-X323	1		
11	REDUCER	A97L-0218-0805#37	1		
12	GEAR	A290-7216-X212	1		
13	O-RING	A98L-0040-0041#173	1		
14	WASHER	A97L-0001-0823#M8H	11		
15	BOLT	A6-BA-10X45	11	LT263	73.5

300kg/500kg payload (Hollow type)

	Parts name	Specifications	Q'ty	Locking	Torque N-m
1	COVER	A290-7220-Z326	3		
2	BOLT	A6-BA-12X35	12	LT263	128.4
3	WASHER PLATE	A290-7220-Z324	3		
4	COLLAR	A98L-0040-0211#121512	12		
5	INSULATOR A	A290-7220-X325	3		
6	INSULATOR B	A290-7220-X328	1		
7	FLANGE	A290-7220-Z112	1		
8	O-RING	JB-OR1A-G95	1		
9	PIPE	A290-7220-X321	1		
10	INSULATOR C	A290-7220-Z323	1		
11	REDUCER	A97L-0218-0891#37	1		
12	GEAR	A290-7216-X212	1		
13	O-RING	A98L-0040-0041#173	1		
14	WASHER	A97L-0001-0823#M8H	11		
15	BOLT	A6-BA-10X45	11	LT263	73.5

6.2.2 In the case of 1000 kg/1500kg payload (Hollow type)

- 1 Set dial gauges, and prepare for single axis mastering after replacement.
- 2 Remove the motor as described in Section 6.1.
- 3 Remove the covers (1), bolts (2), washers (3), insulators A (5) and B (4), flanges (6) , insulators C (7) in that order.
- 4 Remove the bolts (16) and washers (15) that fix the reducer (11) and base and then remove the reducer (11) and the components ahead of it.
- 5 Remove the bolts (13) and washers (12) that secure the reducer and adapter and remove the reducer (11) from the adapter (8).
- 6 Apply sealant to a new reducer as described in Section 6.3 and assemble these components in the reverse order. Install the insulator B (4) after installing the insulator A (5). Replace the O-ring (10) with new ones and put them in place. Be careful not to damage the oil seal. For the tightening torque and the application of LOCTITE, see Fig. 6.2.2 below table.
- 7 Mount the motor as described in Section 6.1.2.
- 8 Supply the reducer with the specified grease as described in Section 3.1.
- 9 Perform single axis mastering as described in Subsection 5.2.5 of MAINTENANCE.

NOTE

When the influence of the damaged pieces generated from broken reducer is concerned about, exchange gear of the J1-axis motor.

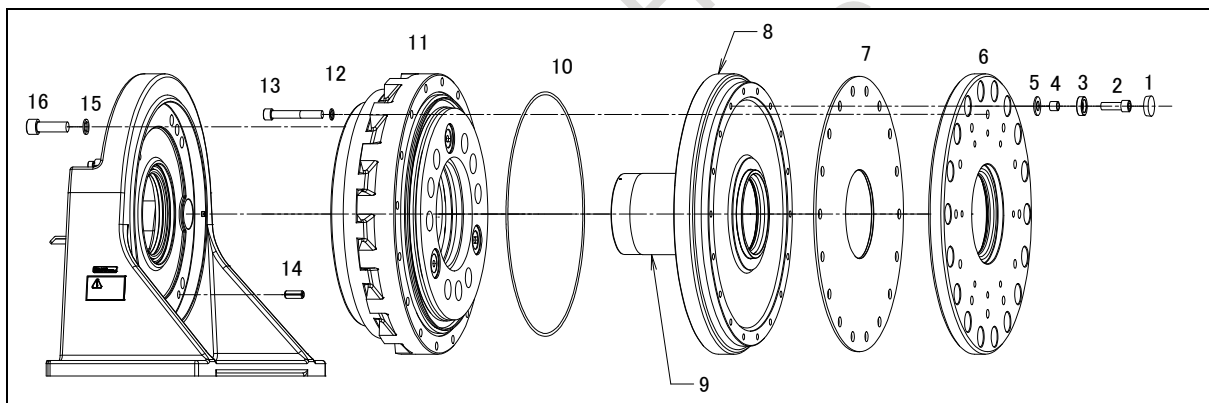

Fig. 6.2.2 Replacing the reducer (1000kg/1500kg payload (Hollow type))

	Parts name	Specifications	Q'ty	Locking	Torque N-m
1	COVER	A290-7220-Z326	18		
2	BOLT	A6-BA-12X35	18	LT263	128.4
3	WASHER	A290-7220-Z324	18		
4	INSULATOR B	A98L-0040-0211#121512	18		
5	INSULATOR A	A98L-0040-0222#30152	18		
6	FLANGE	A290-7220-X105	1		
7	INSULATOR C	A290-7220-X142	1		
8	ADAPTER	A290-7220-X104	1		
9	PIPE	A290-7220-X141	1		
10	O-RING	A98L-0040-0041#281	1		
11	REDUCER	A97L-0218-0819	1		
12	WASHER	A97L-0001-0823#M12H	16		
13	BOLT	A6-BA-12X85	16	LT263	128.4
14	PIN	A6-PS-12X30	1		
15	WASHER	A97L-0001-0823#M16H	15		
16	BOLT	A6-BA-16X50	15	LT263	318.5

6.2.3 In the case of 1000 kg/1500kg payload (Compact type)

- 1 Set dial gauges, and prepare for single axis mastering after replacement.
- 2 Remove flange mounting bolts (1), (2) to flange (3) and remove the flange (3).
- 3 Remove reducer mounting bolts (4) and washers (5) to base and remove reducer (6).
- 4 Apply sealant to a new reducer as described in Section 6.3 and assemble these components in the reverse order. Replace the O ring (7) with new ones and put them in place. Be careful not to damage the oil seal. For the tightening torque and the application of LOCTITE, see Fig. 6.2.3 below table.
- 5 Supply the reducer with the specified grease as described in Section 3.1.
- 6 Perform single axis mastering as described in Subsection 5.2.5 of MAINTENANCE.

NOTE

When the influence of the damaged pieces generated from broken reducer is concerned about, exchange gear of the J1-axis motor.

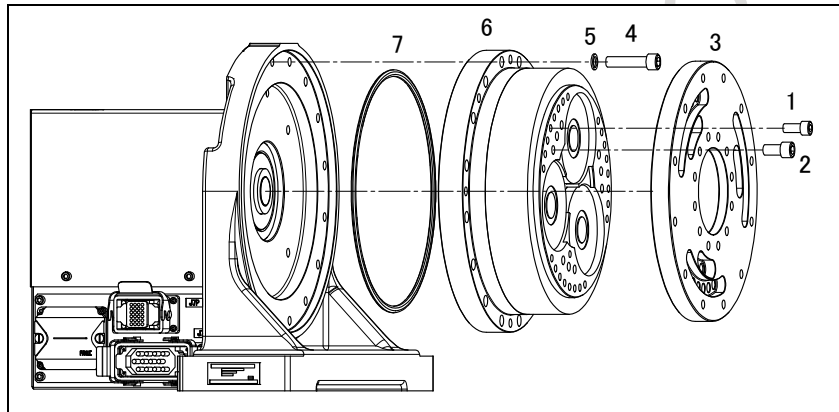

Fig. 6.2.3 Replacing the reducer (1000kg/1500kg payload (Compact type))

	Parts name	Specifications	Q'ty	Locking	Torque N-m
1	BOLT	A6-BA-10X22	24	LT263	73.5
2	BOLT	A6-BA-12X22	9	LT263	128.4
3	FLANGE	A290-7220-X152	1		
4	BOLT	A6-BA-12X50	16	LT263	128.4
5	WASHER	A97L-0001-0823#M12H	16		
6	REDUCER	A97L-0218-0889#171	1		
7	O-RING	JB-OR1A-G270	1		

6.3 SEALANT APPLICATION (1000kg/1500kg payload (Hollow type)) (1000kg/1500kg payload (Compact type))

Washing and degreasing the surfaces to be sealed

- 1 After removing the reducer, the surfaces that were sealed with LOCTITE 518 must be cleaned and all old LOCTITE 518 must be removed. Apply LOCTITE Gasket Remover to the surface to be cleaned. Allow 10 minutes to soften the old LOCTITE 518. After the LOCTITE has softened it can be removed using a scraper.
- 2 Blow air onto the surface to be sealed to remove dust from the tapped holes.
- 3 Sufficiently degrease the reducer's surface to be sealed and the arm's surface to be sealed, using a cloth dampened with solvent. Do not spray solvent directly onto the surface.
- 4 Polish the surfaces of the reducer to be sealed with an oil stone, and degrease them with removal and cleaner again.

⚠ CAUTION

Oil may drip from inside of the reducer. Check that there are no oil drips thoroughly after you have finished degreasing.

Applying sealant

- 5 Make sure that the reducer and surfaces of the items to be sealed are dry (with no oil and grease remover remaining). If they are still wet with oil and grease remover, wipe them dry. Always use a new surface of a cloth so that the grease, once wiped up with the cloth, will not get on the degreased surface. Make sure that no wet solvent exists in the threaded holes or on any sealing surfaces. If solvent is still present, it can prevent the LOCTITE from curing.
- 6 Apply sealant (LOCTITE 518) to the surfaces.

⚠ CAUTION

See descriptions of reducer replacement, and check the areas to which sealant is to be applied to be sure they are clean and dry. Otherwise, the sealant will not adhere properly.

Assembly

- 7 To prevent dust from sticking to the areas to which sealant was applied, mount the reducer as quickly as possible after sealant application. Be careful not to touch the applied sealant. If sealant was wiped off, apply again.
- 8 After installing the reducer, fasten it with bolts and washers quickly so that the mated surfaces are pressed together.
- 9 After attaching the reducer, wipe off any excessive sealant that comes out from the sealed section with a cloth or spatula. Do not use oil and grease remover.

⚠ CAUTION

Do not grease or move the reducer before the sealant sets, as it may allow grease to leak. Before performing greasing, wait one four hours or more after the reducer is mounted.

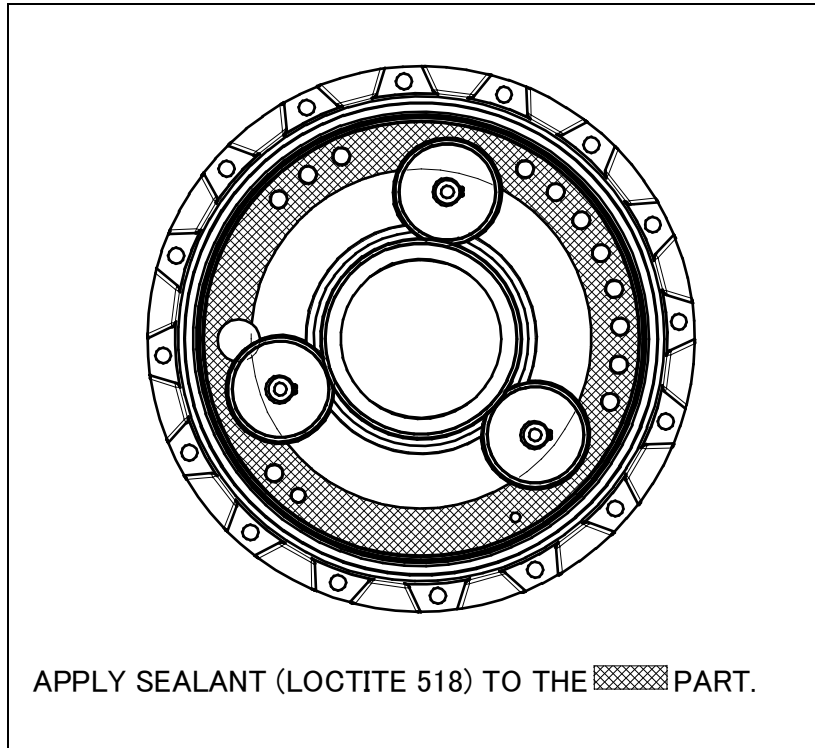

Fig. 6.3 (a) Applying sealant to the reducer (1000kg/1500kg payload (Hollow type))

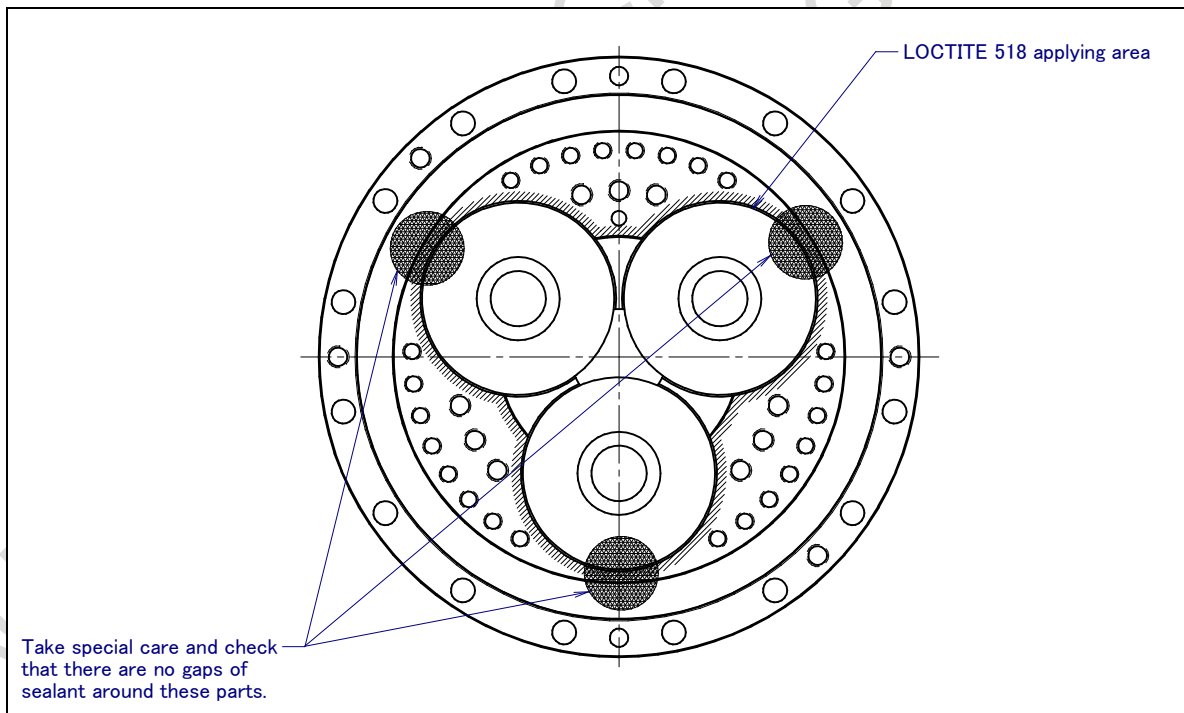

Fig. 6.3 (b) Applying sealant to the reducer (1000kg/1500kg payload (Compact type))

6.4 REPLACING THE GROUND BRUSH (for 300kg/500kg payload (Hollow type) Infinite continuous turn mechanical option)

- 1 Remove bolts M4 x 6 (2 pcs), then remove the plate.
- 2 Remove the bolts M6 x 8 (4 pcs), then remove the cover.
- 3 Remove the auto grease cup.
- 4 Remove the bolts M8 x 12 (2 pcs), then remove the cable.
- 5 Remove the bolts M8 x 40 (2 pcs), then remove the ground brush. The ground brush inside has a spring, load is applied to the axial direction, please be careful.
- 6 Remove the ground brush, then assemble it. For its assembly, please apply the steps above in reversed sequence.

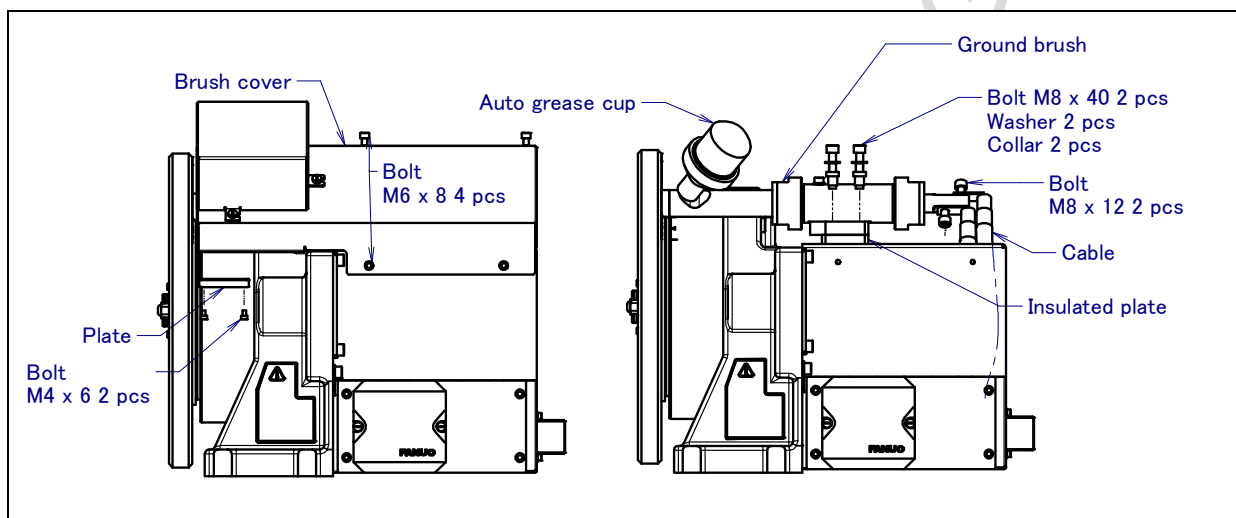

Fig. 6.4 Replacing the ground brush

Replacing parts

Parts name	Specification
Ground brush	A290-7220-V825

6.5 REPLACING THE ROTARY JOINT (for 300kg/500kg payload (Hollow type) Infinite continuous turn mechanical option)

- 1 Remove the brush cover and the ground brush referring to Section 6.4. It is not necessary to remove the auto grease cup from the ground brush.
- 2 Remove bolts M8 x 12 (3 pcs), then remove the motor cover.
- 3 Remove the bolts M3 x 6 (4 pcs), then remove the AS connector.
- 4 Remove the air tubes which are connected to the rotary joint.
- 5 Remove the flange side wiring.
- 6 Remove the low head bolts M8 x 12 (6 pcs), Pull out the rotary joint to the flange side.
- 7 Remove the rotary joint, then assemble it. For its assembly, please apply the steps above in reversed sequence. Refer to Fig. 6.5 (b) about the air tube connection position. Fix the AS cable and the air tubes on the clamp with cable ties.

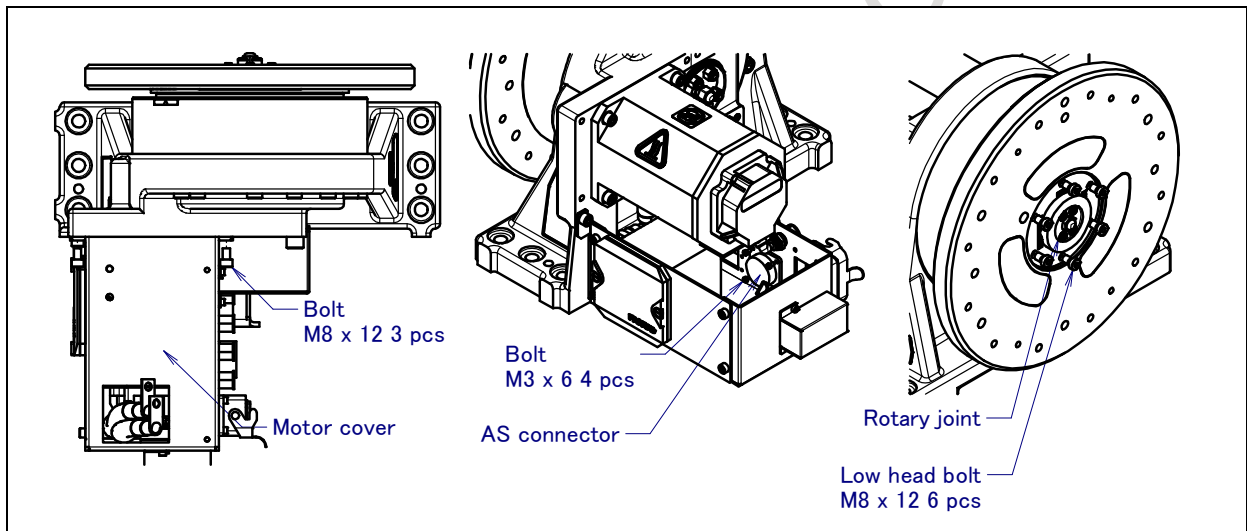

Fig. 6.5 (a) Replacing the rotary joint

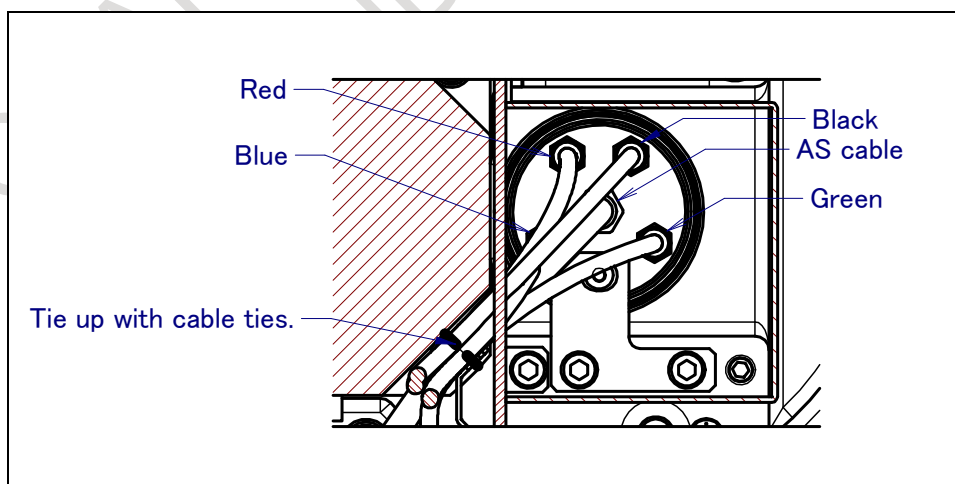

Fig. 6.5 (b) Air tube connection position

Replacing parts

Parts name	Specification
Rotary joint	A290-7220-V824

7 PIPING AND WIRING

7.1 CABLING (WHEN THE HARTING CONNECTOR OPTION IS SELECTED)

Fig. 7.1 shows the cabling in the mechanical unit when the HARTING connector option is selected. (There are no cables in the mechanical unit when the HARTING connector option is not selected.)

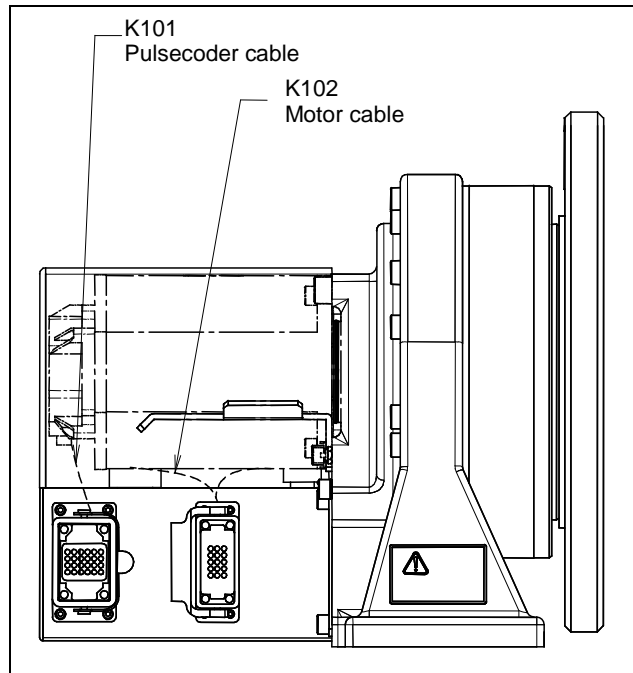

Fig. 7.1 Wiring in the mechanical unit

8 CABLE REPLACEMENT

If a cable is broken or damaged, replace it according to the procedure described in this chapter.

Cautions in handling the Pulsecoder cable

When transporting, installing, or maintaining the positioner, do not detach the Pulsecoder cables carelessly. The cables are provided with the marking tie shown below. If you detached any cable with the marking tie, you need to perform mastering for the robot.

Do not detach any connector unless you replace a motor, Pulsecoder, reducer, or cable.



Fig. 8 Wire mark

If there is a break in or any other damage to a cable, replace the cable according to the procedure described in this chapter. If the connector of a Pulsecoder cable (K101) is detached, the data about the absolute position of the positioner is lost. Once any of these cables is replaced, perform quick mastering while referencing Section 5.2. If the data is lost because of a break in a cable, also perform quick mastering to calibrate the positioner into the previous absolute position.

8.1 REPLACING CABLES

When the HARTING connector option is not selected, turn off the power to the controller, directly remove the motor connector, and replace the cables. When the HARTING connector option is selected, use the procedure below to replace the cables.

In the case of 300kg payload (Hollow type), 300kg/500kg payload (Hollow type), 1000kg/1500kg payload (Hollow type)

- 1 Make sure that the quick mastering reference point is set with reference to Subsection 5.2.4.
- 2 Turn off the controller power.
- 3 Remove the motor cover while referencing Chapter 6.
- 4 Remove the four M6 x 10 bolts from the battery box fixing plate, and remove the plate together with the battery. Take care not to break the battery connection cable by excessively pulling it.
- 5 Remove the three M8 x 12 bolts that fasten the connector box, and remove the connector box.
- 6 Remove the motor connector and the cable.
- 7 Detach the cables from the connector box. The K101 cable can be detached from the connector box by removing the four M4 x 8 bolts, and the K102 cable can be detached by removing the four M3X8 bolts, housing, and insert.
- 8 Remove the battery connection cable.
- 9 Remove the ground wire.
- 10 Reverse the removal steps to install new cables. Take care not to cause the cables to be caught and cut in metal plates while installing them. Also, take care not to break the cables by pulling them.
- 11 Perform quick mastering. (See Chapter 5).

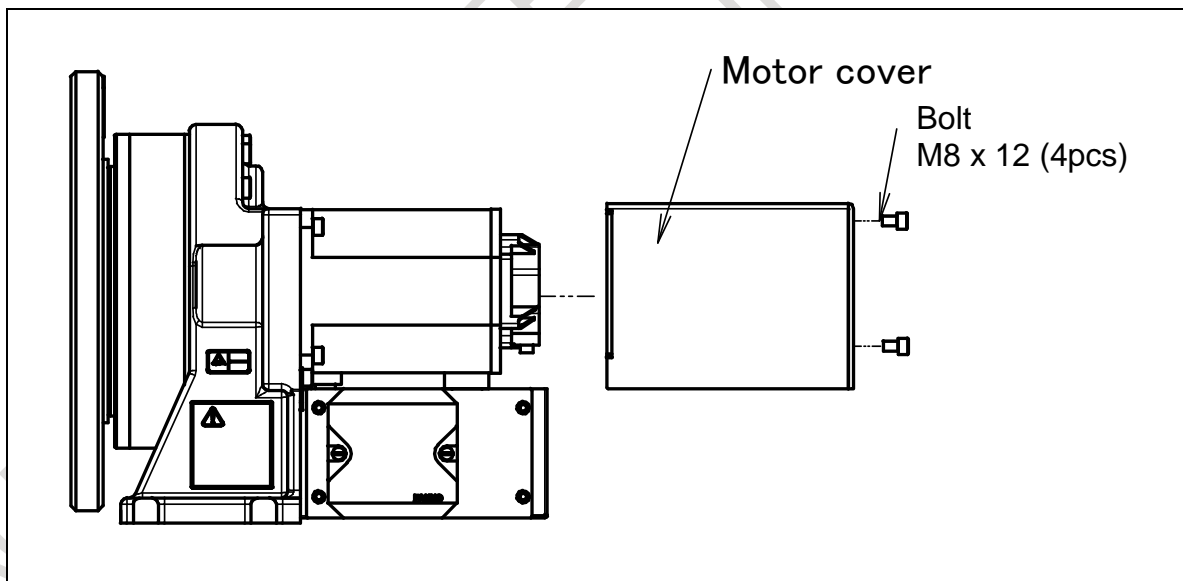

Fig. 8.1 (a) Replacing cables 1
300kg payload (Hollow type), 300kg/500kg payload (Hollow type), 1000kg/1500kg payload (Hollow type)

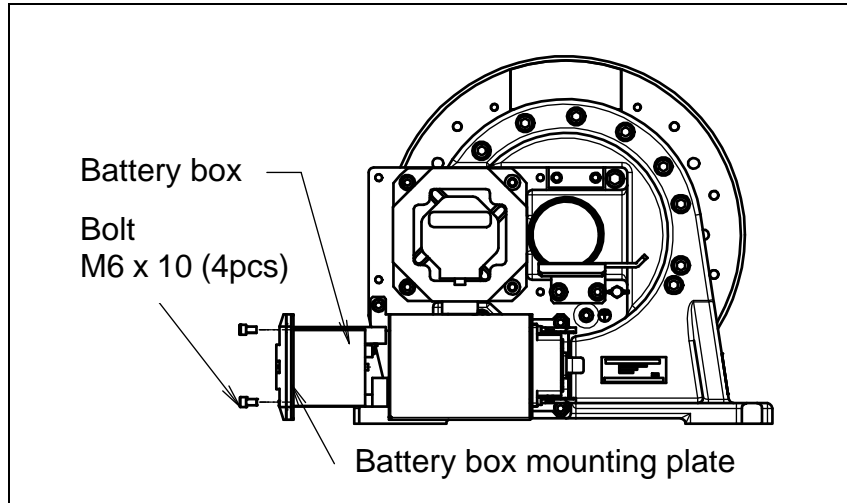

Fig. 8.1 (b) Replacing cables 2
300kg payload (Hollow type), 300kg/500kg payload (Hollow type), 1000kg/1500kg payload (Hollow type)

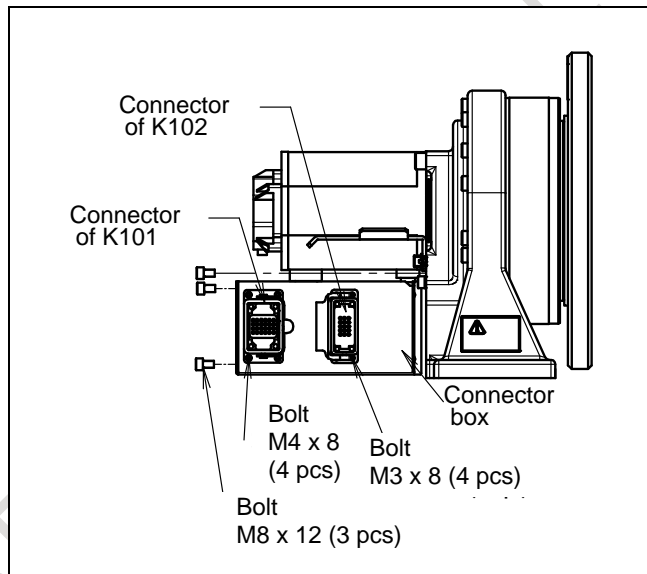
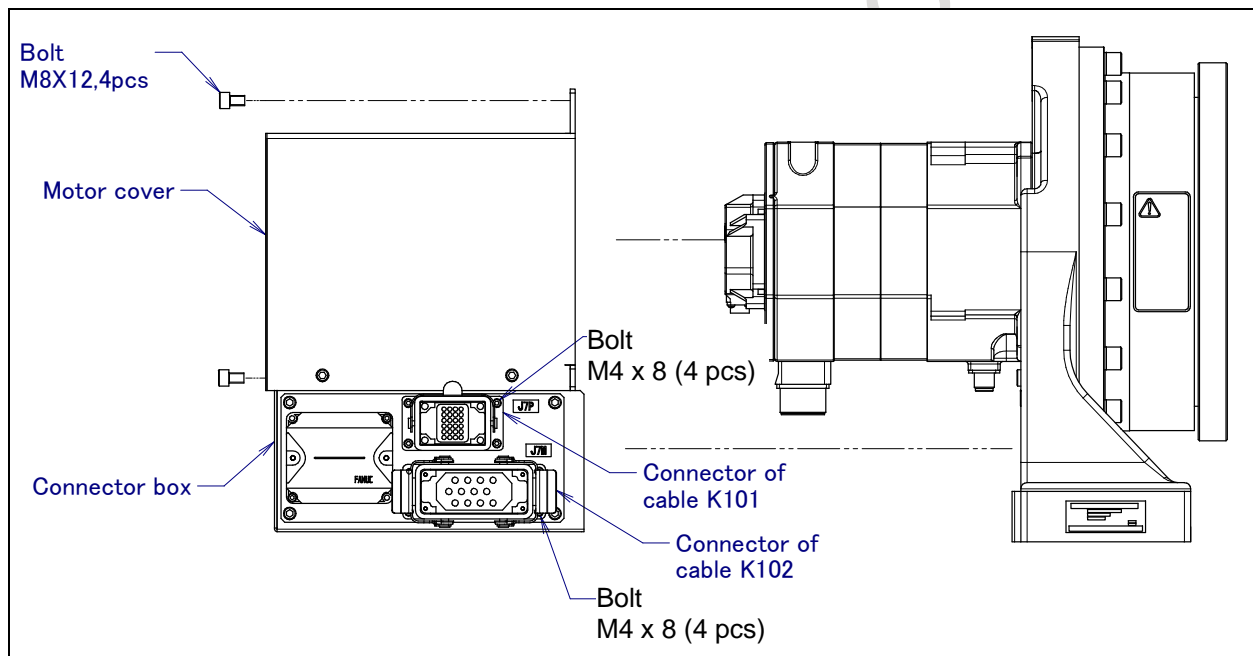

Fig. 8.1 (c) Replacing cables 3
300kg payload (Hollow type), 300kg/500kg payload (Hollow type), 1000kg/1500kg payload (Hollow type)

In the case of 1000kg/1500kg payload (Compact type)

- 1 Make sure that the quick mastering reference point is set with reference to Subsection 5.2.4.
- 2 Turn off the controller power.
- 3 Remove the motor cover while referencing Chapter 6.
- 4 Remove the for M8 x 12 bolts from the battery box fixing plate, and remove the plate together with the battery. Take care not to break the battery connection cable by excessively pulling it.
- 5 Remove the motor connector and the cable.
- 6 Detach the cables from the connector box. The K101 cable can be detached from the connector box by removing the four M4 x 8 bolts, and the K102 cable can be detached by removing the four M4 x 8 bolts, housing, and insert.
- 7 Remove the battery connection cable.
- 8 Remove the ground wire.
- 9 Reverse the removal steps to install new cables. Take care not to cause the cables to be caught and cut in metal plates while installing them. Also, take care not to break the cables by pulling them.
- 10 Perform quick mastering. (See Chapter 5).



**Fig. 8.1 (d) Replacing cables 1
1000kg/1500kg payload (Compact type)**

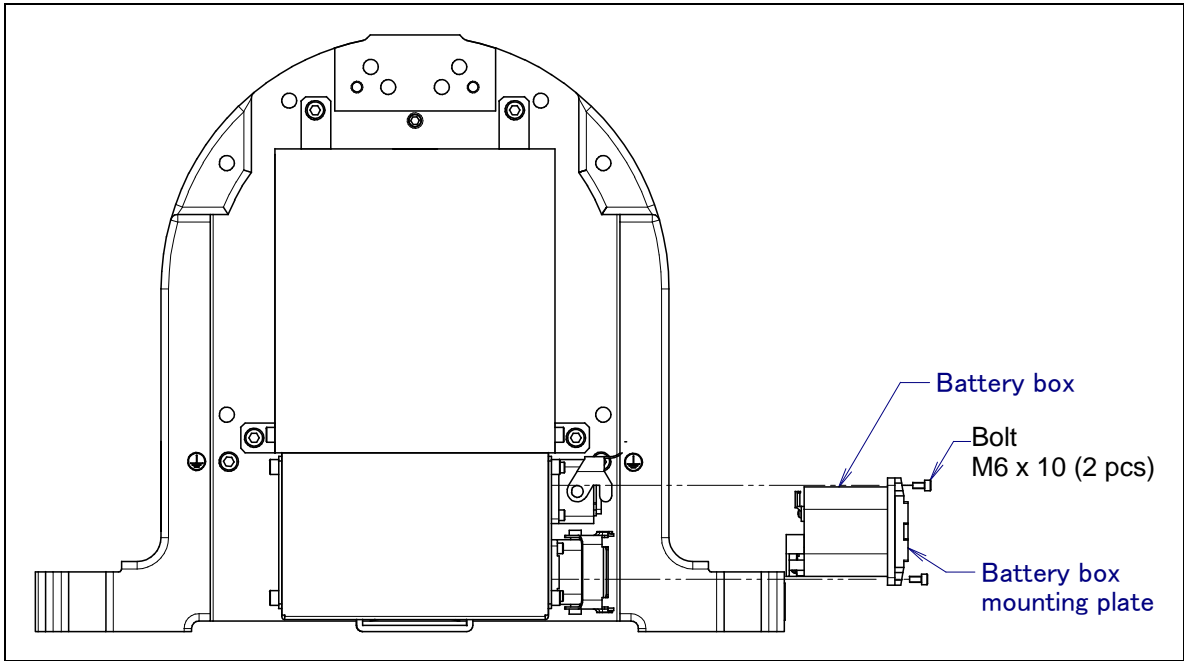

**Fig. 8.1 (e) Replacing cables 2
1000kg/1500kg payload (Compact type)**

JR AUTOMATION TECHNOLOGY
JDOWLING

JR AUTOMATION TECHNOLOGIES INC*
JDOWLING

II. CONNECTION

JR AUTOMATION TECHNOLOGIES INC*
JDOWLING

JR AUTOMATION TECHNOLOGIES INC*
JDOWLING

1 POSITIONER OUTLINE DRAWING

When installing peripheral equipment, be careful not to cause interference with the positioner body. For installation, see Section 3.3 of CONNECTION and use through holes provided on the base.

1.1 OUTLINE DRAWING

Figs. 1.1 (a) to (e) show the outer dimensions and the operation area of the positioner and follower unit. Refer to Section 3.3 for base dimension of installation.

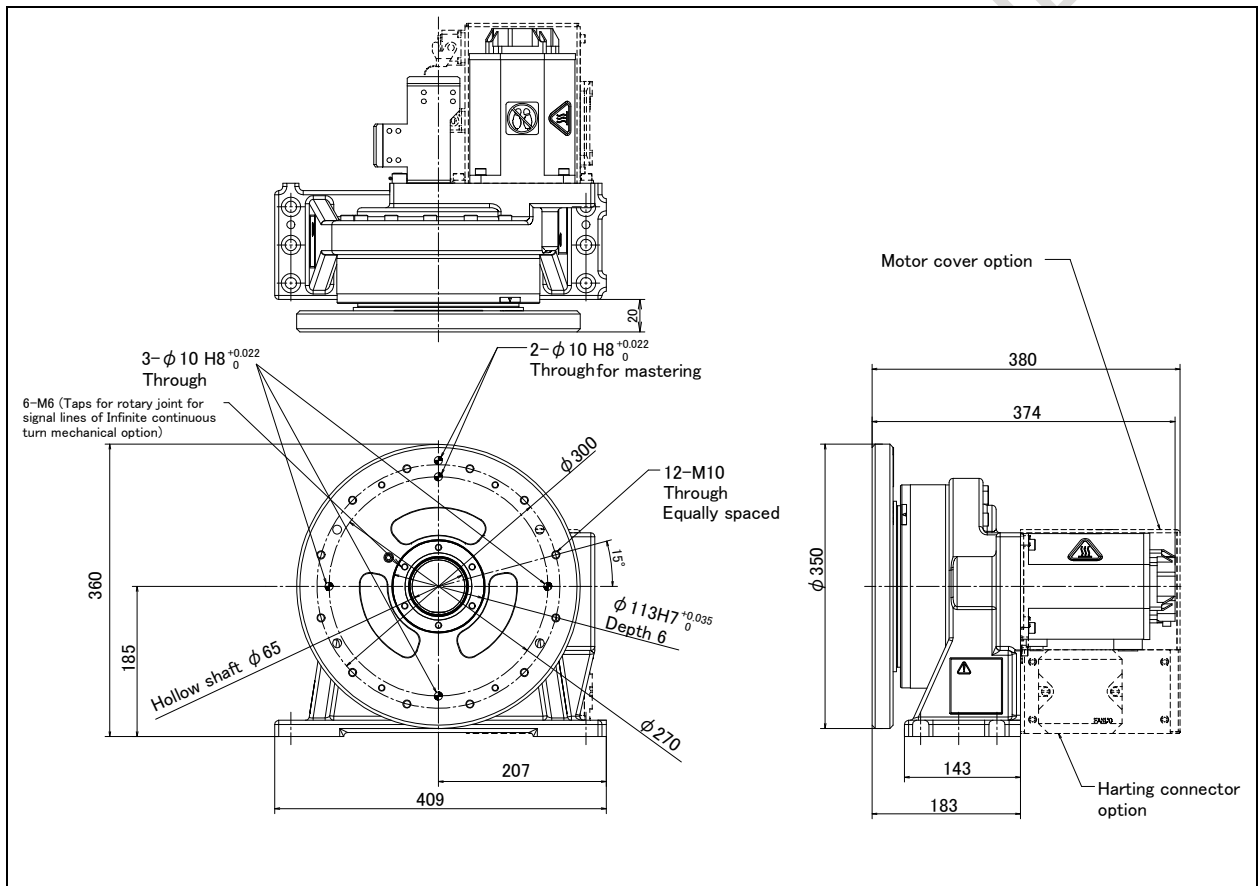

Fig. 1.1 (a) Outline of 1 axis positioner (300kg payload (Hollow type)), (300kg/500kg payload (Hollow type))

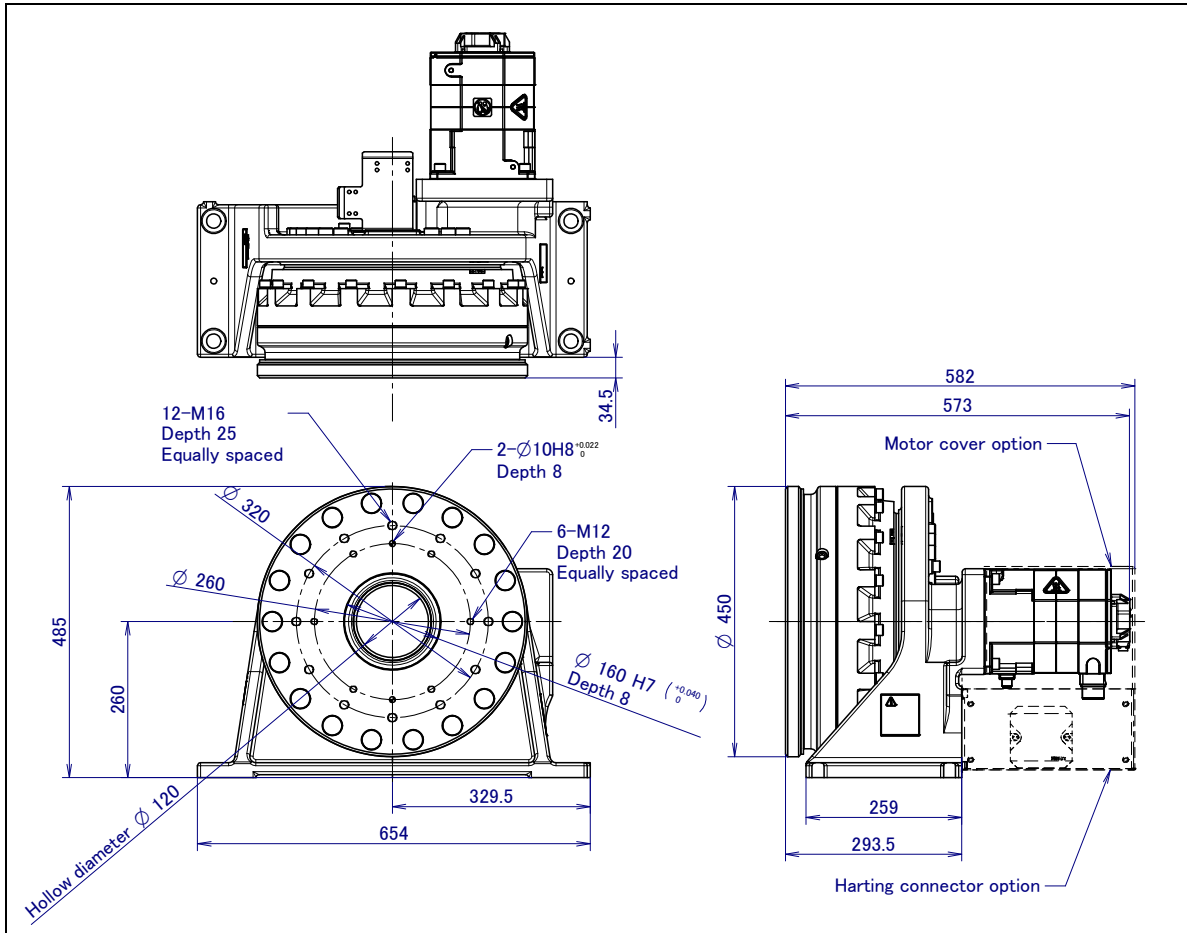

Fig. 1.1 (b) Outline of 1 axis positioner (1000kg/1500kg payload (Hollow type))

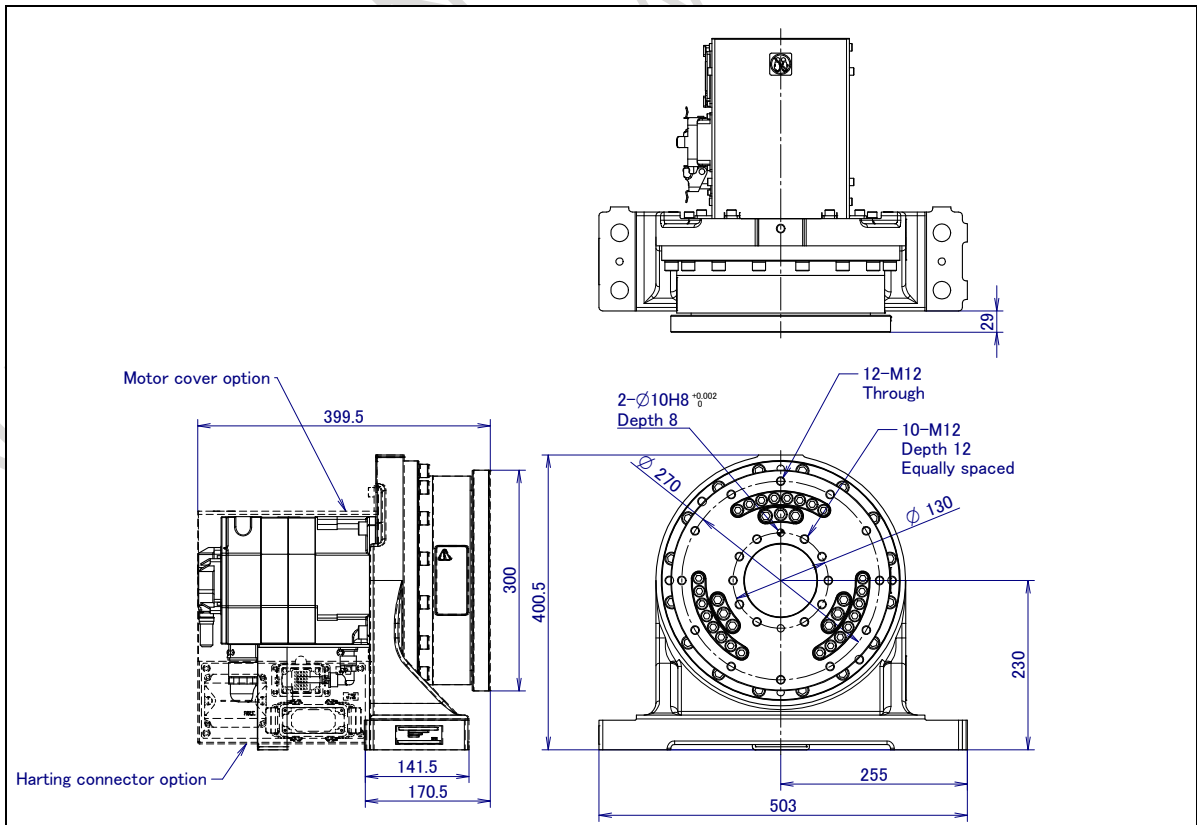

Fig. 1.1 (c) Outline of 1 axis positioner (1000kg/1500kg payload (Compact type))

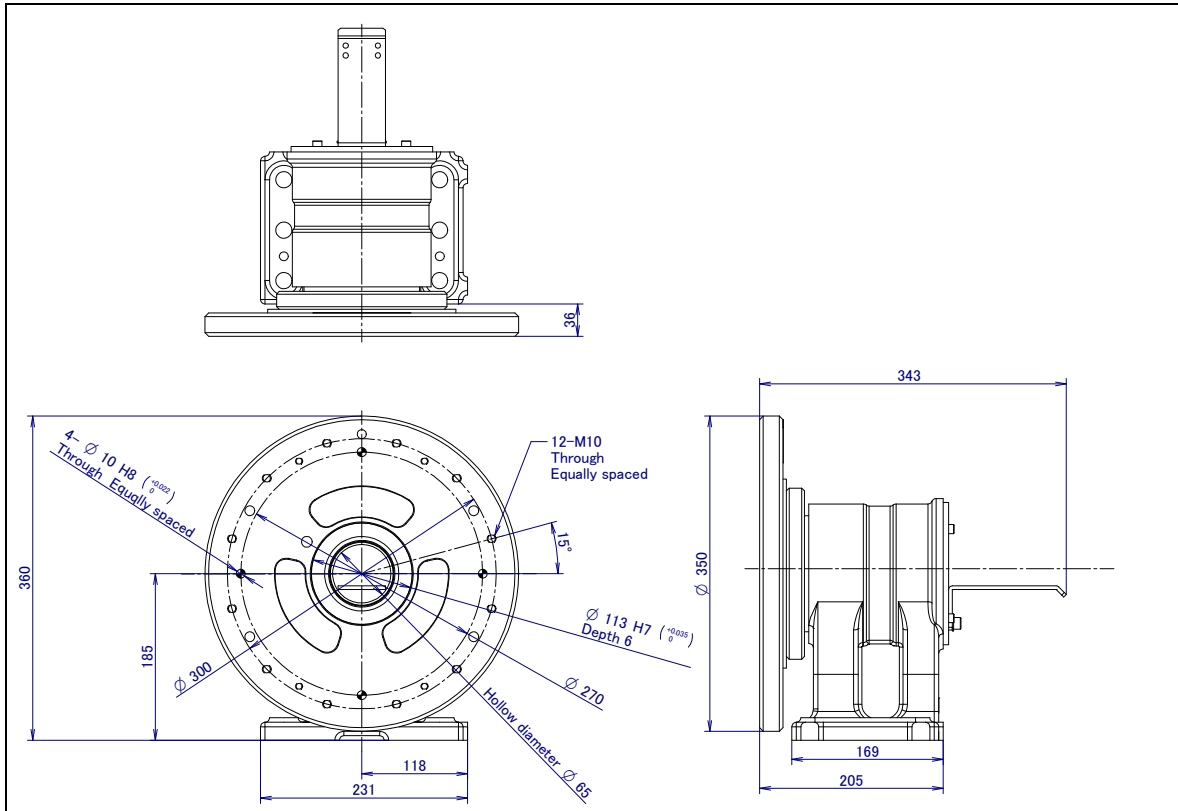

Fig. 1.1 (d) Outline of follower unit (insulated flange) (option)

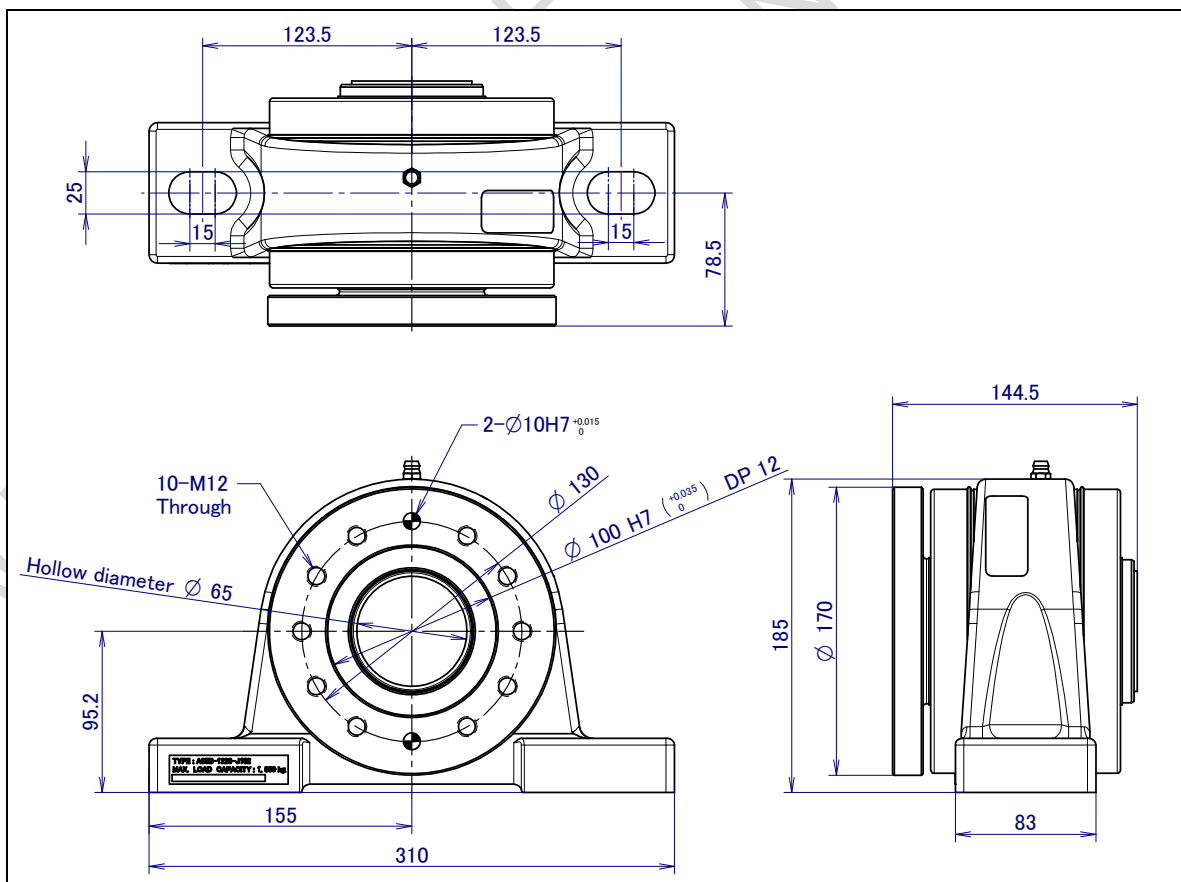

Fig. 1.1 (e) Outline of follower unit (non-insulated flange) (option)

2 MOUNTING DEVICES ON THE POSITIONER

NOTE

Wipe oil off the flange surface before mounting the unit. Otherwise, the unit may be misaligned.

2.1 POSITIONER LOAD CONDITION

Fig. 2.1 (a) to (d) show the positioner load conditions.

Use the positioner so that the load condition falls within the range in the table and the allowable load inertia and allowable load moment in the table are satisfied.

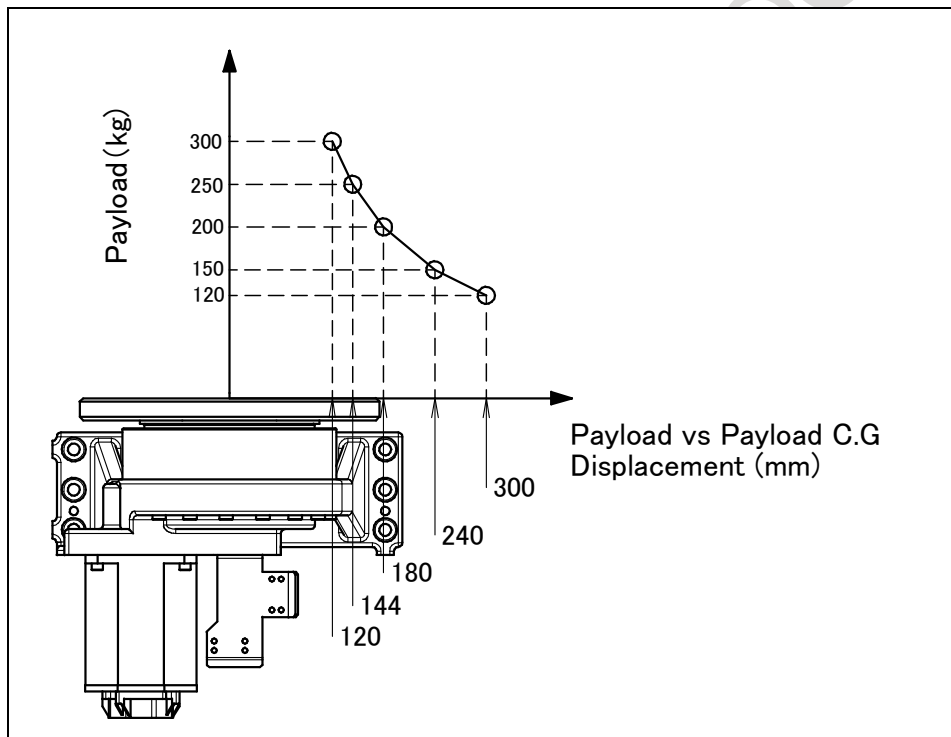

Fig. 2.1 (a) Positioner allowable load condition (300kg load capacity)
300kg payload (Hollow type), 300kg/500kg payload (Hollow type)

	300kg pay load capacity
Allowable load moment (Mr)	36 kgf·m (353 N·m)
Allowable bending moment (Mb)	250kgf·m (2450 N·m)
Allowable load inertia (J)	2350 kgf·cm·s ² (240kg·m ²)

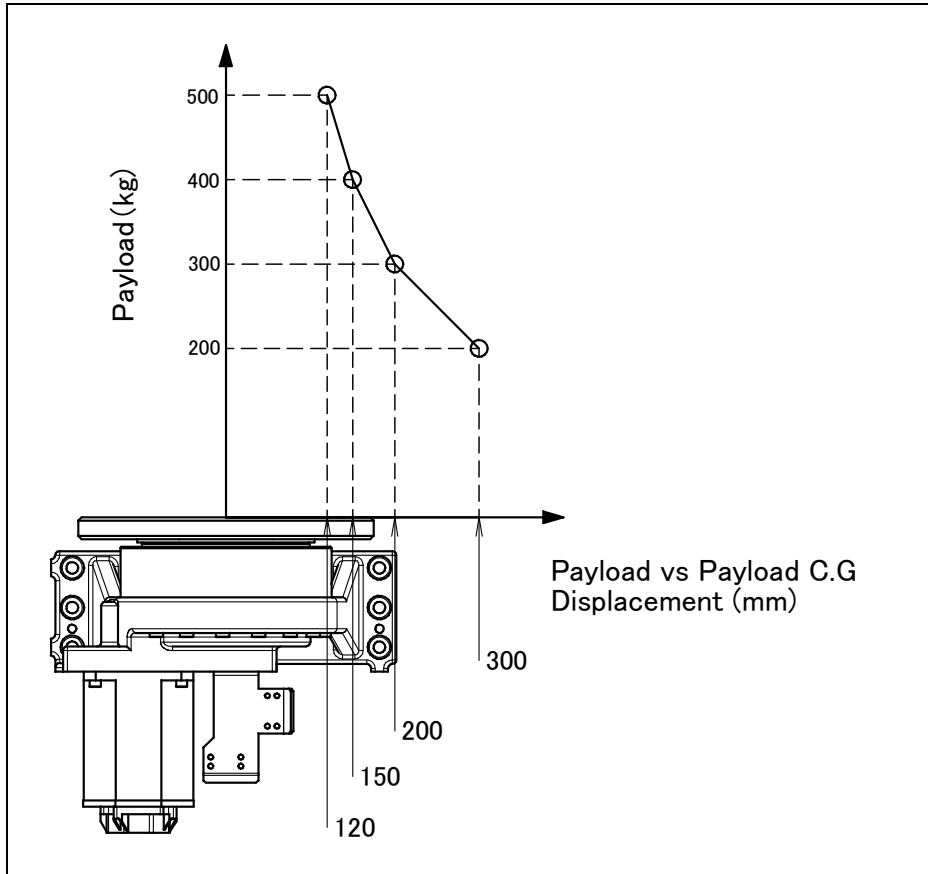

Fig. 2.1 (b) Positioner allowable load condition (500kg payload capacity)
300kg/500kg payload (Hollow type)

	500kg payload capacity
Allowable load moment (Mr)	60 kgf·m (588 N·m)
Allowable bending moment (Mb)	400kgf·m (3920 N·m)
Allowable load inertia (J)	3673 kgf·cm·s ² (360kg·m ²)

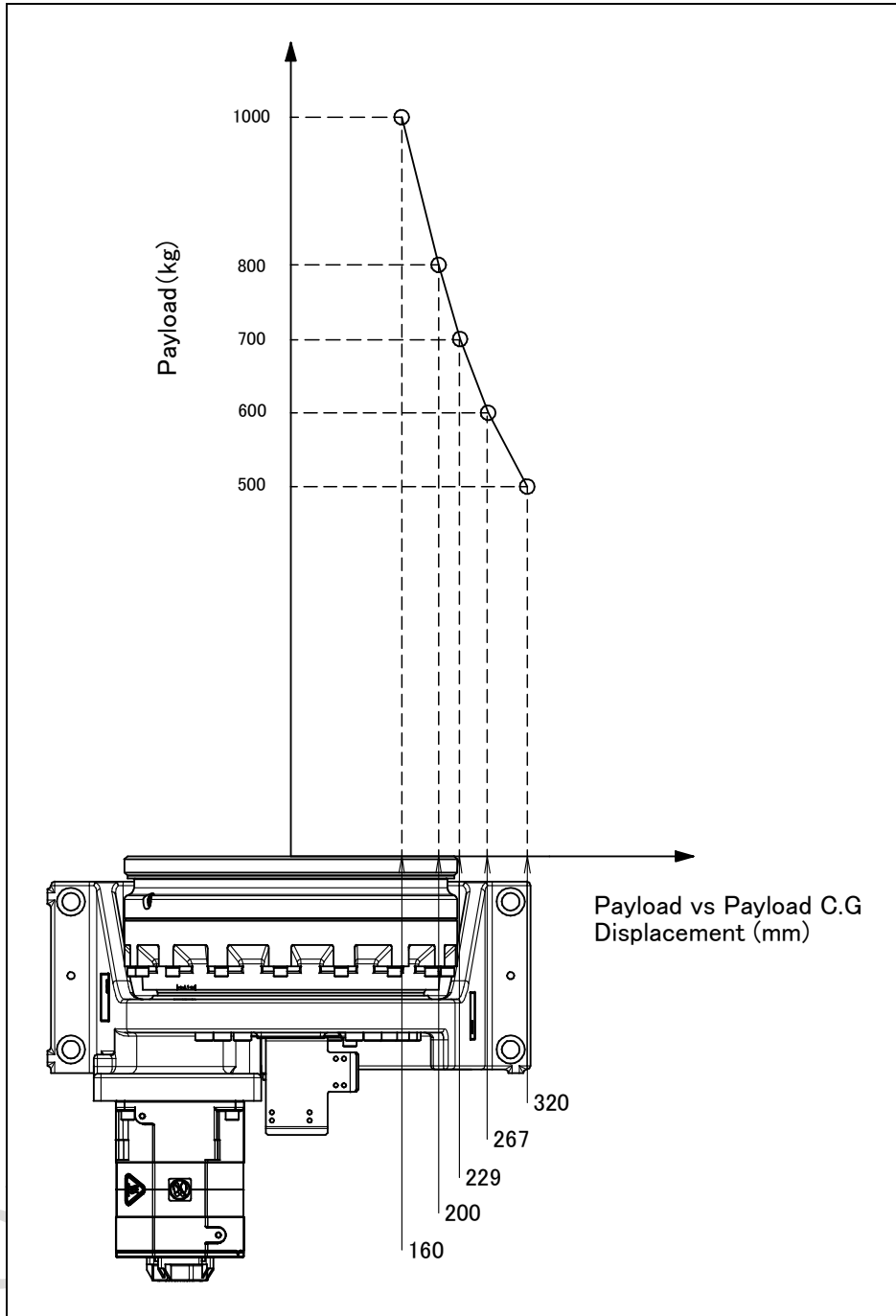

Fig. 2.1 (c) Positioner allowable load condition (1000kg payload capacity)
1000kg/1500kg payload (Hollow type), 1000kg/1500kg payload (Compact type)

	1000kg payload capacity
Allowable load moment (Mr)	160 kgf·m (1568 N·m)
Allowable bending moment (Mb)	2100kgf·m (20580 N·m)
Allowable load inertia (J)	4700 kgf·cm·s ² (460kg·m ²)

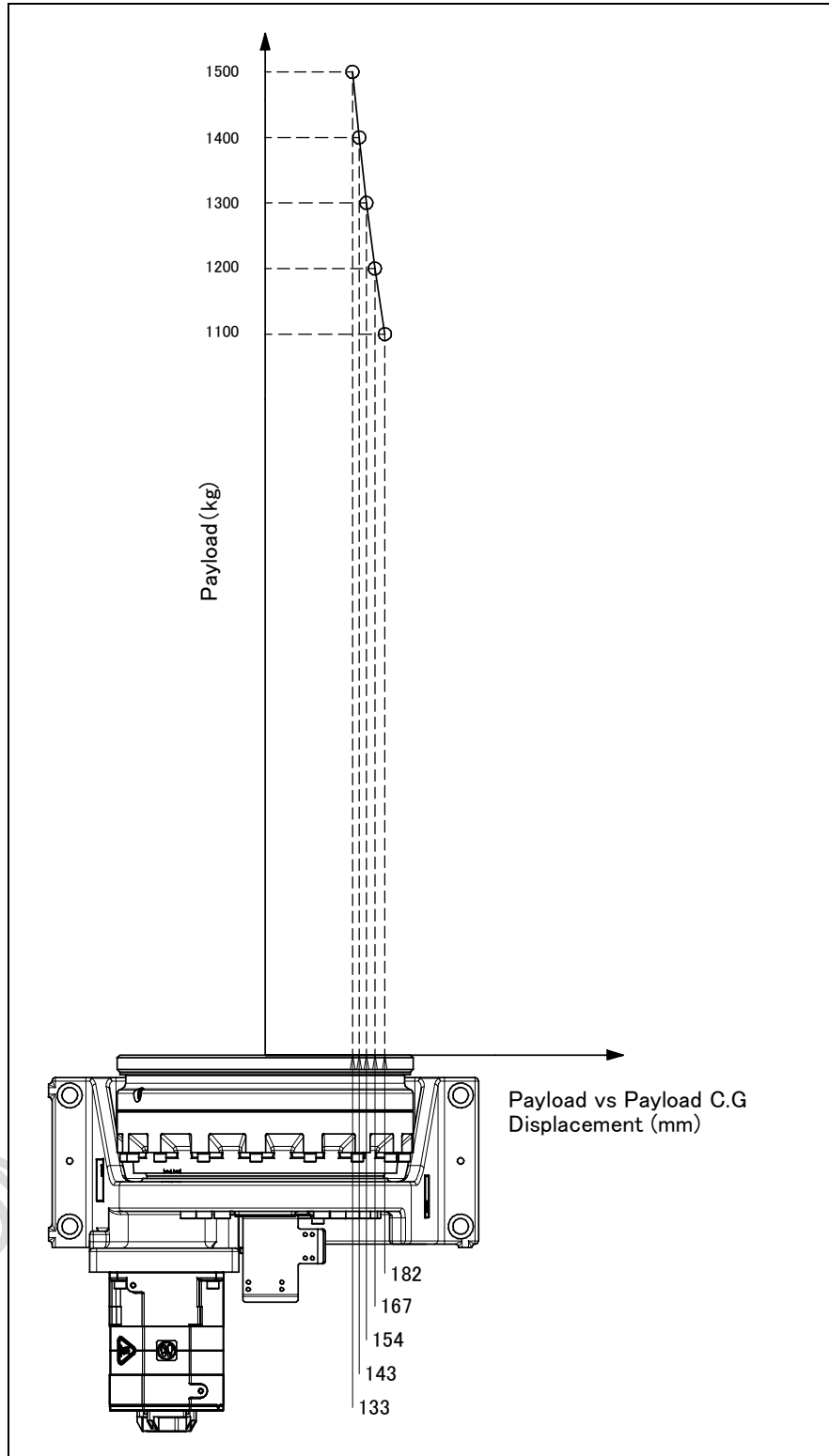

Fig. 2.1 (d) Positioner allowable load condition (1500kg payload capacity)
 1000kg/1500kg payload (Hollow type), 1000kg/1500kg payload (Compact type)

	1500kg payload capacity
Allowable load moment (Mr)	200 kgf·m (1960 N·m)
Allowable bending moment (Mb)	2100kgf·m (20580 N·m)
Allowable load inertia (J)	7000 kgf·cm·s ² (686kg·m ²)

2.2 CHANGING METHOD OF PAYLOAD SPECIFICATION

About Max payload shift function

In Positioner, the best two servo motion parameters are prepared. The best acceleration and deceleration operation operation can be achieved by setting the parameter matched to the payload specification. The parameter is changed by executing the following KAREL programs (It is abbreviated as KAREL for Changing method of payload specification thereafter.)

1000kg/1500kg payload (Hollow type) (A05B-1220-J102)

P1HSET10.PC: 1000kg payload specification
P1HSET15.PC: 1500kg payload specification

300kg/500kg payload (Hollow type) (A05B-1220-J103)

P1HSET03.PC: 300kg payload specification
P1HSET05.PC: 500kg payload specification

1000kg/1500kg payload (Compact type) (A05B-1220-J104)

P1CSET10.PC: 1000kg payload specification
P1CSET15.PC: 1500kg payload specification

The following procedure is based on an example of 1000kg/1500kg payload (Hollow type) (A05B-1220-J102).

Positioner is set to specified payload specification by customer when it is shipped.

⚠ CAUTION

When positioner over payload specification of set, (Refer to specification table in PREFACE and Section 2.1.of CONNECTION), set in appropriate payload specification. If the positioner is operated with wrong setting, the function and the lifetime of the robot would deteriorate.

Method of shifting

There are the following two in the method of executing KAREL for changing method of payload specification. Please use it properly according to the purpose.

- 1) Method of executing KAREL program by using "Call program" → Refer to Subsection 2.2.1.
 - The KAREL program is set in the program call instruction of the TP program and the parameter is set by specifying with the argument that shows the group number, and executing it. The parameter of 1-axis positioner of a specific group can be switched in this method.

Instruction that calls program

Example of program :

1 : CALL P1HSET10(1)

Group number specification for argument

- 2) Method of executing KAREL program directly → Refer to Subsection 2.2.2.
 - Select and execute the KAREL program in program select screen.
 - To set same load parameter to multiple 1-axis positioner the multi group system, use this method to switch the parameter at once.

⚠ CAUTION

Execute KAREL for Changing method of wrist payload specification in the state of cold start mode. Be careful that the paths and the cycle time of an existing teach program change if KAREL for changing method of wrist payload specification is executed

Below section explains the method of executing KAREL for changing wrist payload specification.

2.2.1 Method of executing KAREL program by using “Call program”

- * The following procedures assume the thing of changing 1-axis positioner of the first group to the 1000kg payload specification.

Execution procedure

- 1 Call the system variable screen.

[MENU] key ? Select “System” and press F1 key(screen) ? Select “System variables”

- 2 Set system variables \$KAREL_ENB to 1.
- 3 Open TP program edit screen.
- 4 Select “call program” from among the program instruction

F1 key (INST) ? Select “CALL” ? Select “CALL program”

Then, the following screens are displayed.

SYST-039	Operation	Mode	T2	Selected
PROGRAM list				JOINT 10 %
1	A1		5	
2	HOME_IO		6	
3	P1HSET10		7	
4	P1HSET15		8	
A1				1/2
1: CALL ...				
[End]				
Select item				
PROGRAM	MACRO	KAREL	STRINGS	

- 5 Press F3 key (KAREL). Then, select KAREL. The following screen will be displayed. Then select P1HSET10 of 1000kg payload specification from among that.

SYST-039	Operation	Mode	T2	Selected
KAREL list				JOINT 10 %
1	GEMDATA		5	MEM_PORT
2	GET_HOME		6	PSCOLD
3	P1HSET10		7	
4	P1HSET15		8	
A1				1/2
1: CALL ...				
[End]				
Select item				
PROGRAM	MACRO	KAREL	STRINGS	

- 6 Press F4 key (select). Choose "CONSTANT" from there. Then, it becomes the following screens.

```
SYST-039 Operation Mode T2 Selected
A1          LINE 0      T2 ABORTED
A1          JOINT      10%
                                     1/2

1:  CALL P1HSET10 ( Constant )
[ End ]

[ CHOICE ]
```

- 7 Enter group number (1 in this case) while the cursor is at "Constant".

```
SYST-039 Operation Mode T2 Selected
A1          LINE 0      T2 ABORTED
A1          JOINT      10%
                                     1/2

1:  CALL P1HSET10 ( 1 )
[ End ]

POINT                                TOUCHUP>
```

- 8 Execute this program.

Press the [FWD] key while pressing the [SHIFT] key.

Then, the following screens are displayed. This shows the thing that KAREL P1HSET10.PC of 1000kg payload specification is executed.

This means specification is changed to payload 1000kg specification.

Please turn off the controller power and turn it on.

```

SRVO-333 Power off to reset
A1                LINE 0          T2 ABORTED
USER              JOINT 10%
1000kg parameter set. (GP: 1)

----- WARNING -----
- Path and Cycle Time is Changed !! -
-----

Please power off
  
```

- 9 Turn on the controller power again.

This completes the parameter switching.

2.2.2 Method of executing KAREL program directly

Use scene

For instance, it is assumed that the following multi group systems exist.

1st group: 1-axis positioner

2nd group: 1-axis positioner

To set 1-axis positioner in 1st and 2nd group to 1000kg payload specification, the method explained below will allow you to do it at once.

NOTE

If you want to 1-axis positioner of 1st group to 1000kg payload specification and 1-axis positioner of 2nd group to 1500kg payload specification, Method of this chapter cannot be used.

In that case, please make two programs as follows, and do the parameter change by the method of Chapter 1.

- 1 Turn on the controller power again after executing the program 1.
- 2 Turn on the controller power again after executing the program 2.

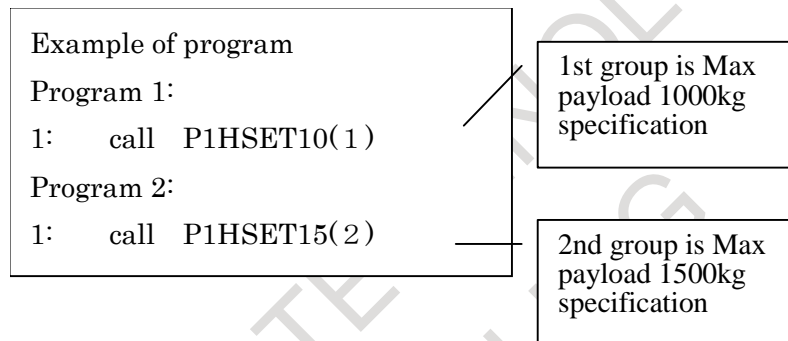

Execution procedure

- 1 Call the system variable screen.

[MENU] key ? Press F1 key (screen) after selecting "system"? Select system variables
--

- 2 Set system variables \$KAREL_ENB to 1.
- 3 Call program select screen and select "

[SELECT] key? select KAREL by F1 key (type)

Then, three KAREL programs are displayed as follows.

A1	LINE 0	T2	ABORTED
Select	G1	JOINT	10%
	710186 bytes free		1/7
No.	Program name	Comment	
1	GEMDATE	PC [GEM Vars]	
2	GET_HOME	PC [Get Home Pos]	
3	P1HSET10	PC [1000kg payload]	
4	P1HSET15	PC [1500kg payload]	
5	MEM_PORT	PC []	
6	PSCOLD	PC []	
[TYPE] CREATE DELETE MONITOR [ATTR]>			

- Place the cursor to the KAREL program of the load to be set, and press [ENTER] key. P1HSET10.PC KAREL of 1000kg payload specification is selected in below screen. The selected program name is displayed to two places as follows.

Selected program name is shown.

```

P1HSET10      LINE 0      T2  ABORTED
Select                               G1  JOINT  10%
                               710186 bytes free      3/7
No.   Program name      Comment
 1  GEMDATE      PC [ GEM Vars      ]
 2  GET_HOME     PC [ Get Home Pos   ]
 3  P1HSET10     PC [ 1000kg payload ]
 4  P1HSET15     PC [ 1500kg payload ]
 5  MEM_PORT     PC [                  ]
 6  PSCOLD       PC [                  ]

P1HSET10 is selected
[TYPE] CREATE DELETE MONITOR [ATTR]>
    
```

- Execute the program.

Press the [FWD] key while pressing the [SHIFT] key.

Then, the following screens will be displayed. This is case of executing KAREL P1HSET10.PC of Max payload 1000kg specification.

This means 1st group is changed to Max payload 1000kg specification.

This means 2nd group is changed to Max payload 1000kg specification.

Please turn off the power supply and turn it on.

```

SRVO-333 Power off to reset
P1HSET10      LINE 0      T2  ABORTED
USER                               JOINT  10%

1000kg parameter set. (GP: 1)

1000kg parameter set. (GP: 2)

----- WARNING -----
- Path and Cycle Time is Changed !! -
-----

Please power off
    
```

- Turn on the controller power again.

This completes the parameter switching.

3 TRANSPORTATION AND INSTALLATION

3.1 TRANSPORTATION

Use a crane to transport the positioner. For the 300 kg payload (Hollow type) or 300 kg/500kg payload (Hollow type), thread a rope through the M10 eyebolts. For the 1000 kg/1500kg payload (Hollow type), thread a rope through the M16 eyebolts. For the 1000 kg/1500kg payload (Compact type), thread a rope through the M12 eyebolts. (See Figs. 3.1 (a) to (c).)

After installation, remove transport equipment. In case of 1000 kg/1500kg payload (Compact type), a metal plate for prevention of fall is attached when Harting option is selected, so remove it after installation.

CAUTION

When transporting a positioner, be careful not to damage a motor connector with a sling for lifting the positioner.

WARNING

- 1 When an end effector and peripherals are installed on a positioner, the center of gravity of the positioner changes and the positioner might become unstable while being transported.
If the positioner becomes unstable, remove the tooling and place the positioner into the transportation position. This will position the unit center of gravity correctly. It is recommended to transport the end effector and peripherals separately from the positioner.
- 2 Do not pull the eyebolt horizontally.
- 3 Do not thread a chain or the like through the transport member.
- 4 Before moving the positioner by using transport equipment, check and tighten any loose bolts.

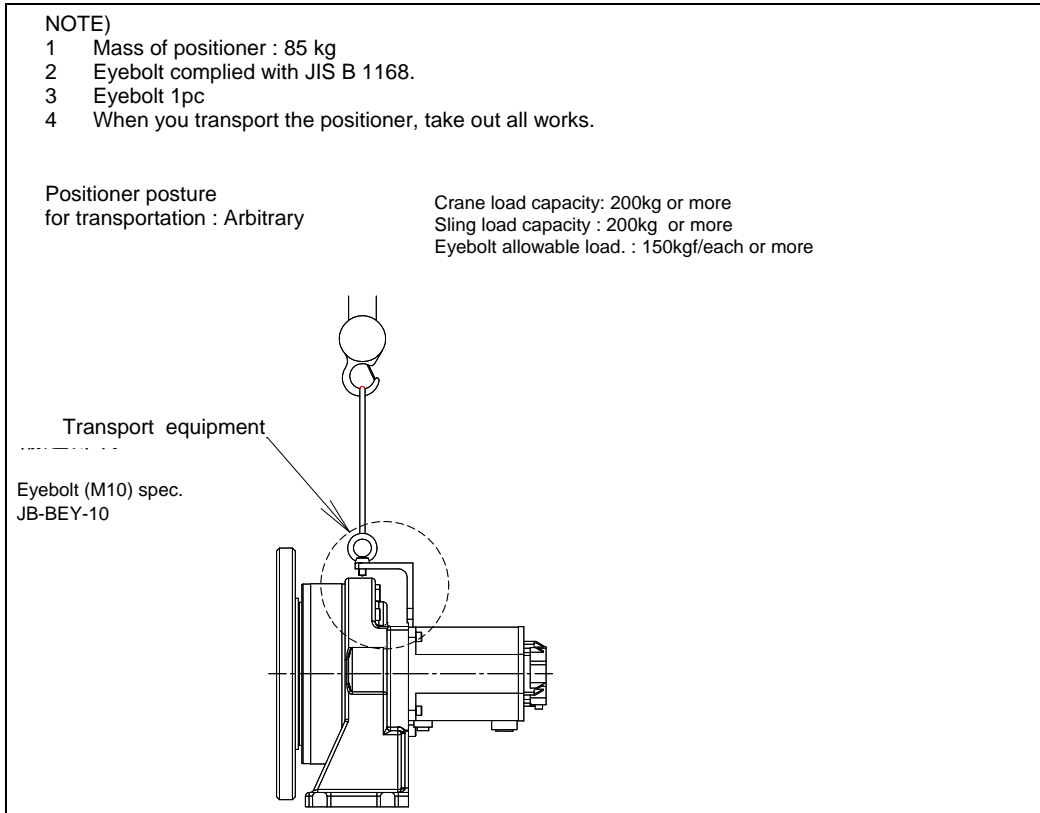

**Fig. 3.1 (a) Carrying the positioner with a crane
(300kg payload (Hollow type)), (300kg/500kg payload (Hollow type))**

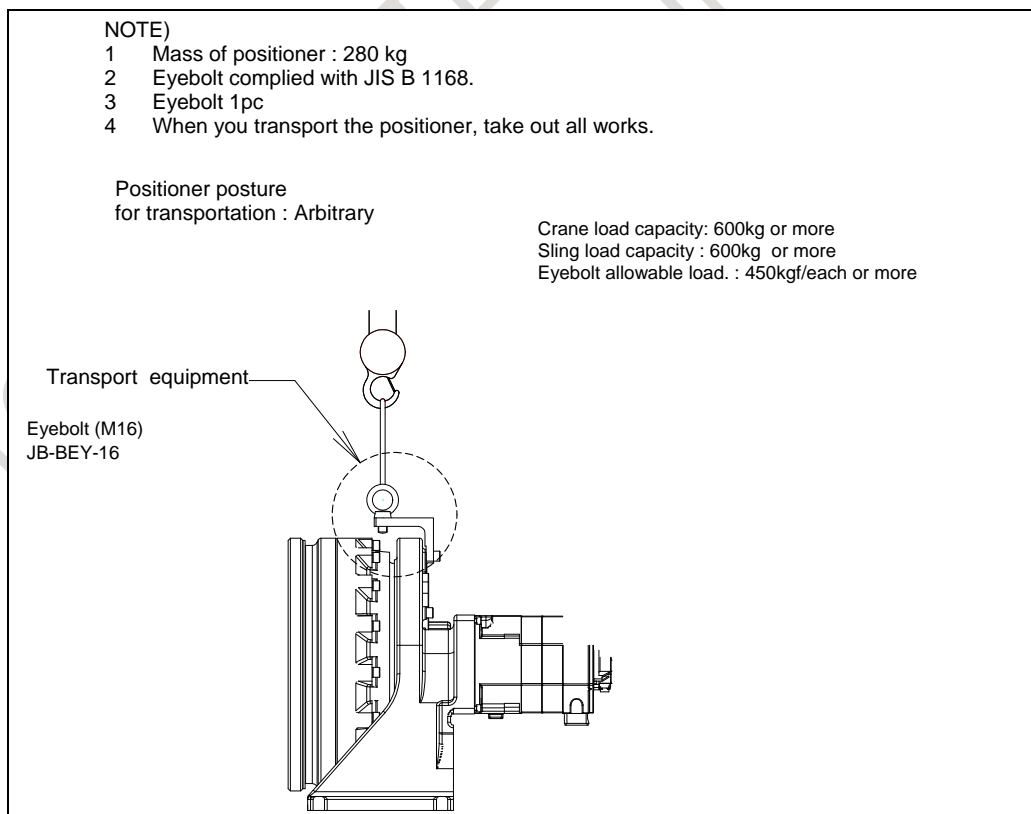

Fig. 3.1 (b) Carrying the positioner with a crane (1000kg/1500kg payload (Hollow type))

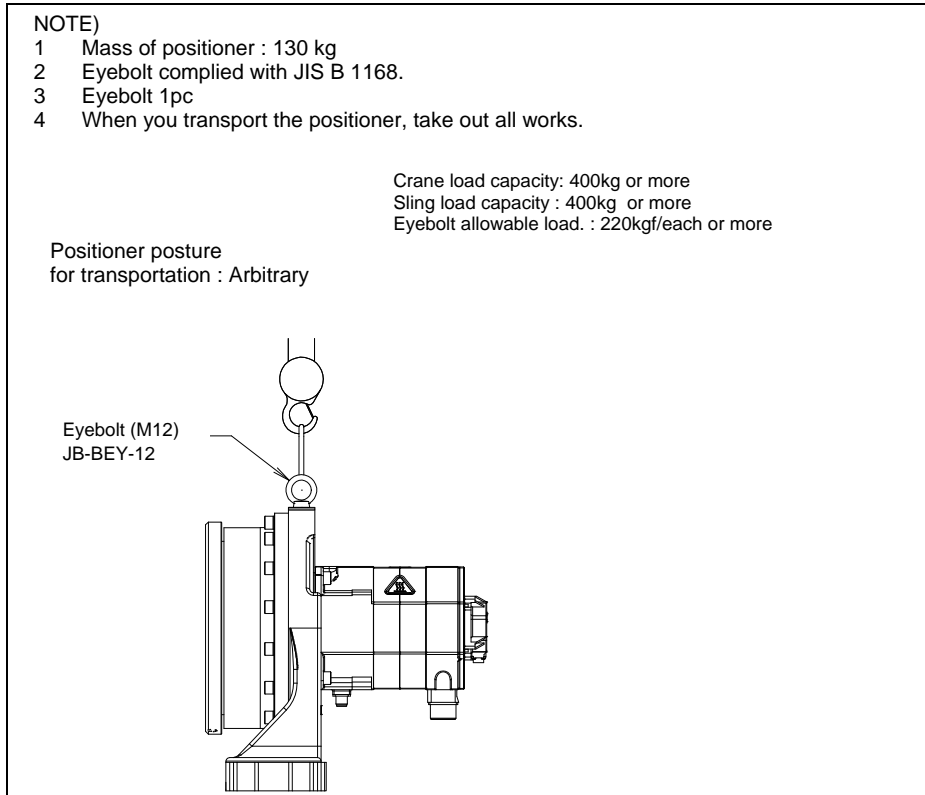

Fig. 3.1 (c) Transportation using a crane (1000kg/1500kg payload (Compact type))



WARNING

When HARTING option (A05B-1220-J116) is not selected for 1000kg/1500kg payload (Compact type) Install transport equipment option (A05B-1220-J103) to prevent positioner from overturning.

3.2 STORING THE POSITIONER

When storing the positioner, keep it in the posture with the following NOTES.

NOTE

- 1 Before storing a positioner for a long term, take measures for securing the positioner to prevent it from falling.
- 2 The flange surface is likely to rust, so apply antirust oil to the flange surface to save it for a long period of time.

3.3 INSTALLATION

- (1) Before installation
Wipe oil off the flange because it is factory-oiled.

There is no insulated flange for 1000kg/1500kg payload (Compact type) (Spec : A05B-1220-J104) and follower unit (non-insulated flange) (Spec : A05B-1220-J152), so it is necessary to prepare the structure for insulation by customer. Examine it referring to Fig.3.3 (a). Please pay attention not to do conduction with a bolt fixing an insulation plate enough.

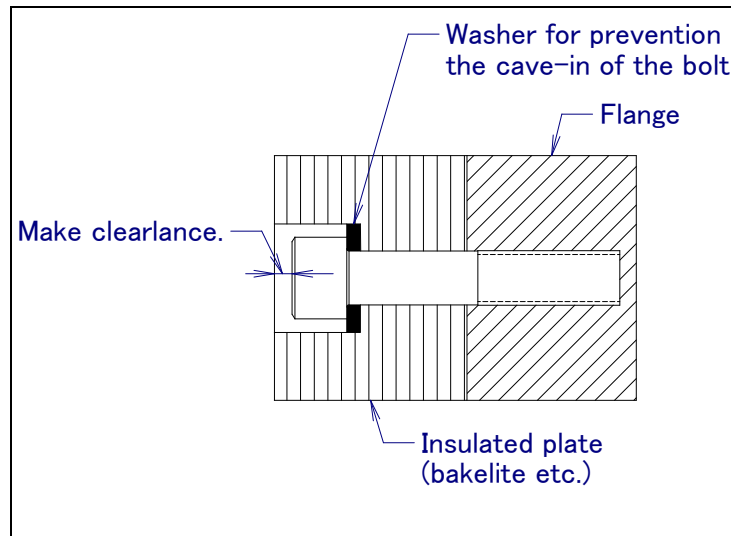

Fig. 3.3 (a) Structure for insulation

Fig. 3.3 (b) to (f) shows the dimensions of the base of the positioner main body and the follower unit.

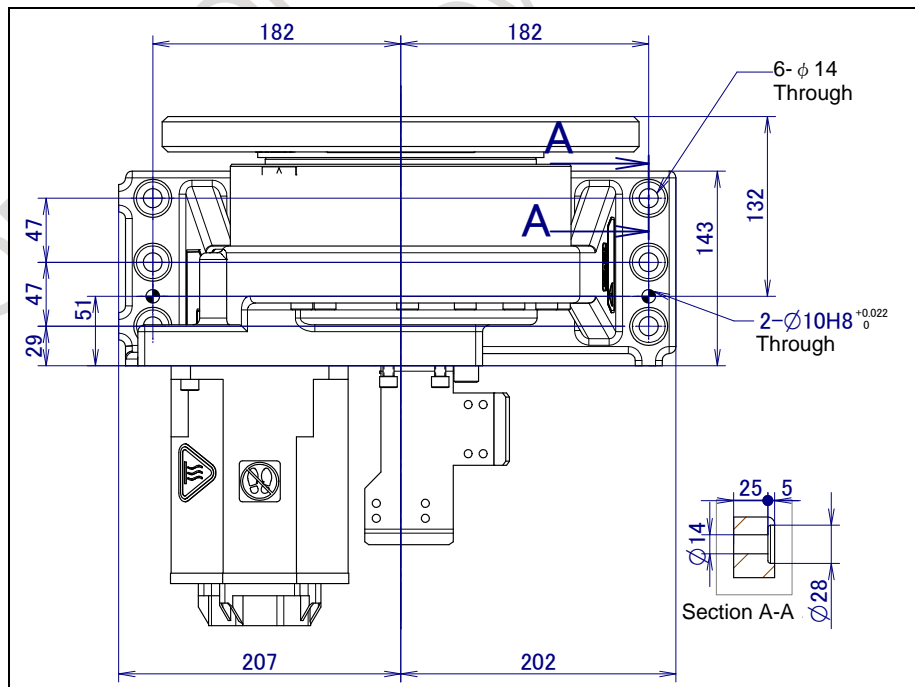

Fig. 3.3 (b) Dimensions of the base of the positioner main body
(300kg payload (Hollow type)), (300kg/500kg payload (Hollow type))

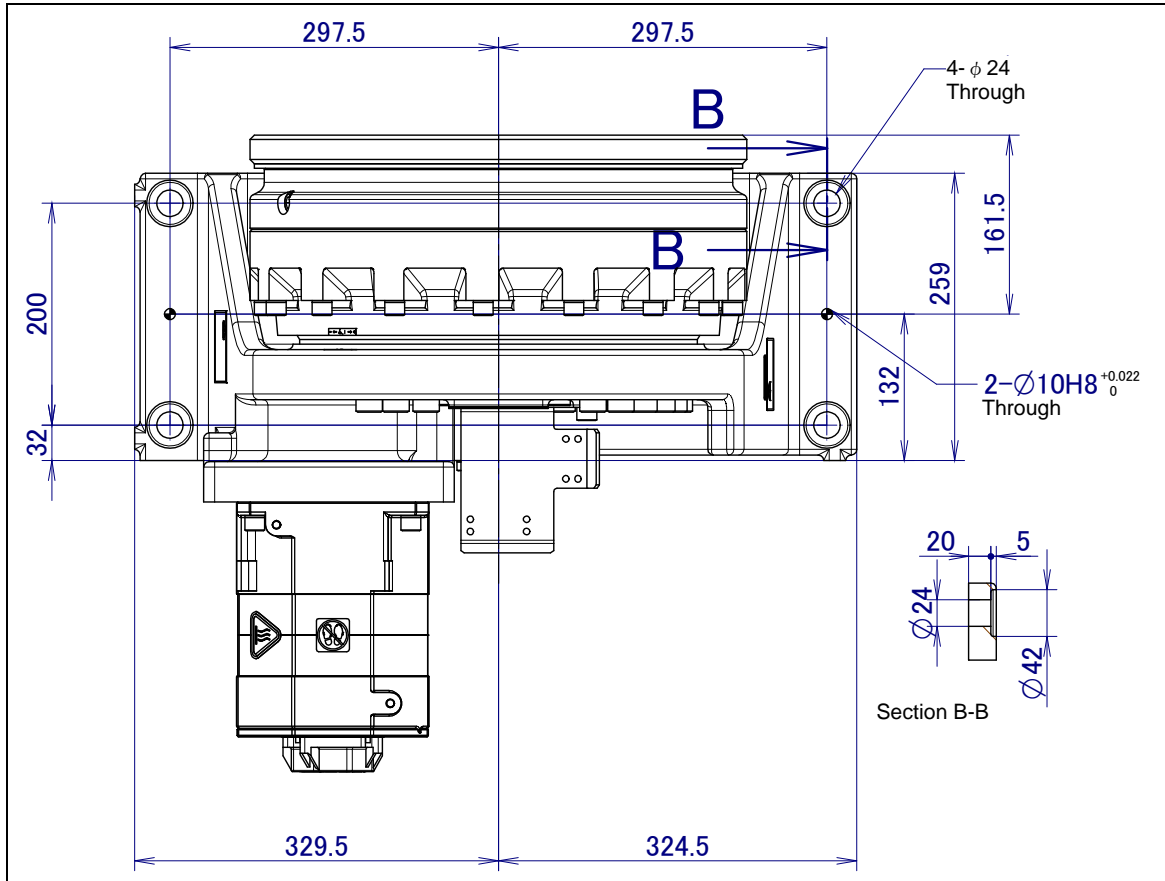

Fig. 3.3 (c) Dimensions of the base of the positioner main body (1000kg/1500kg payload (Hollow type))

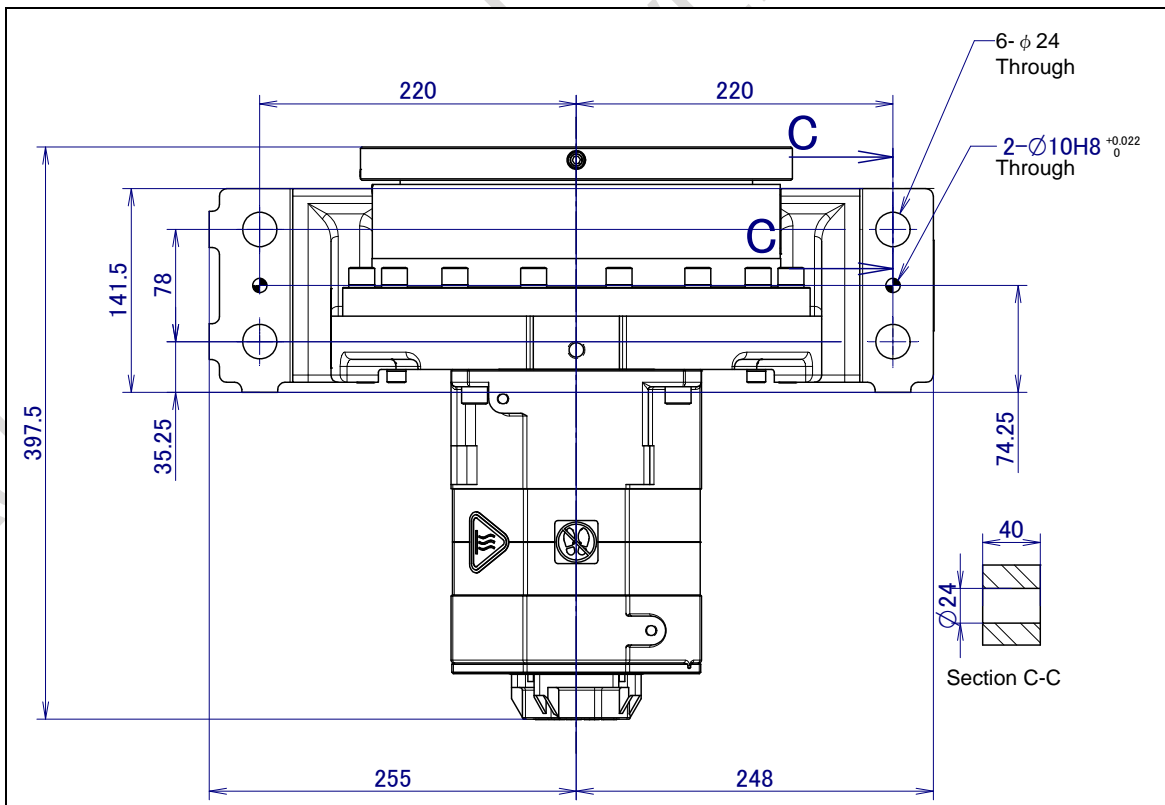

Fig. 3.3 (d) Dimensions of the base of the positioner main body (1000kg/1500kg payload (Compact type))

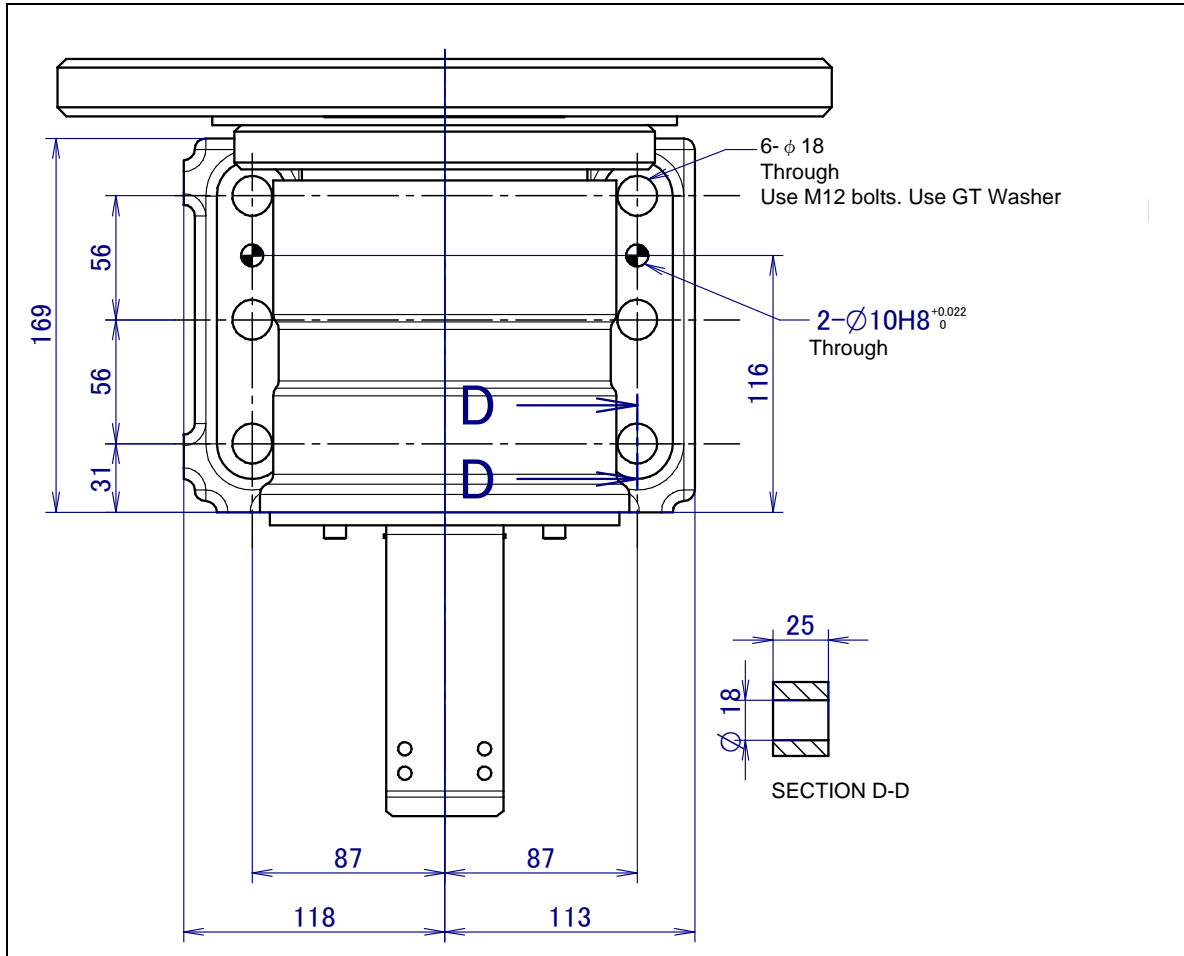

Fig. 3.3 (e) Dimensions of the base of the positioner follower unit (insulated flange)

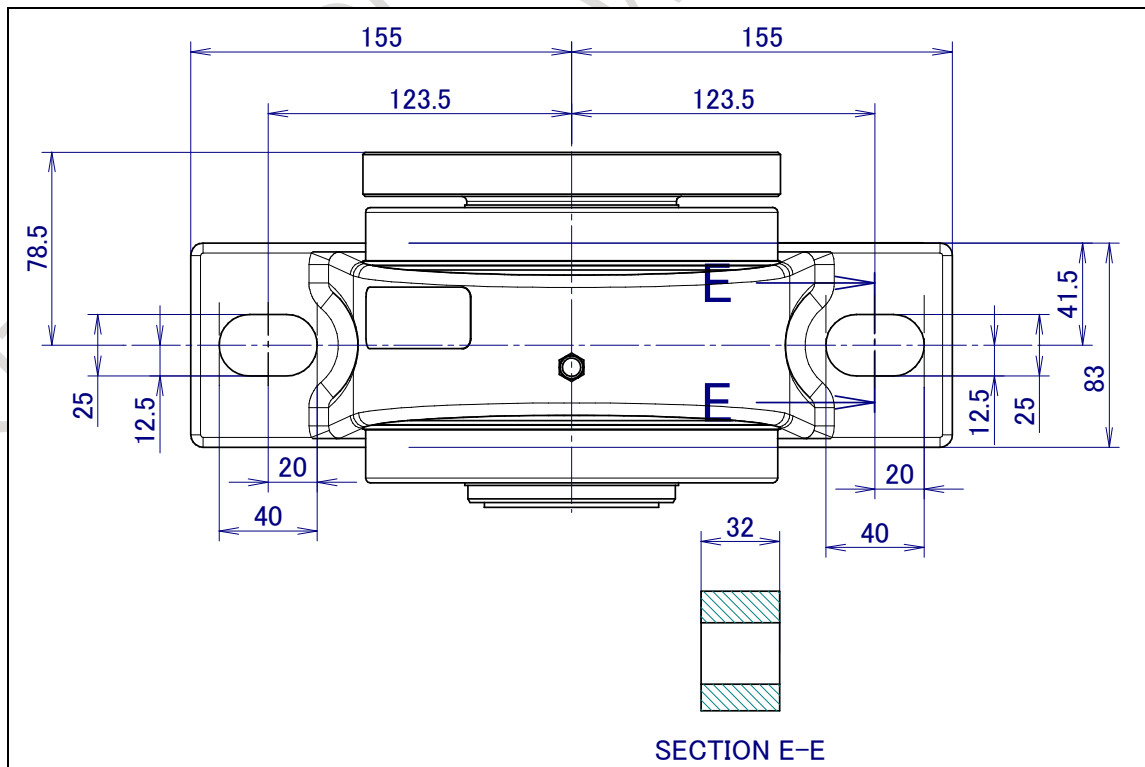

Fig. 3.3 (f) Dimensions of the base of the positioner follower unit (non-insulated flange)

Fig. 3.3 (g) shows an example of installing the 300kg payload (Hollow type) or 300kg/500kg payload (Hollow type) positioner and the follower unit (insulated flange). In this example, the floor plate is fixed with four M20 chemical anchors (Tensile strength 400N/mm^2 or more), and the positioner base is fastened to the floor plate with six M12 x 40 bolts (Tensile strength 1200N/mm^2 or more). or six M12 x 50 bolts (Tensile strength 1200N/mm^2 or more). The follower unit base is fastened with six M12 x 70 bolts (Tensile strength 1200N/mm^2 or more) and six GT washers.

When compatibility must be maintained in teaching the positioner mechanical unit replacement, use the mounting surface.

The customer shall arrange for the positioning pin, anchor bolts, and floor plate.

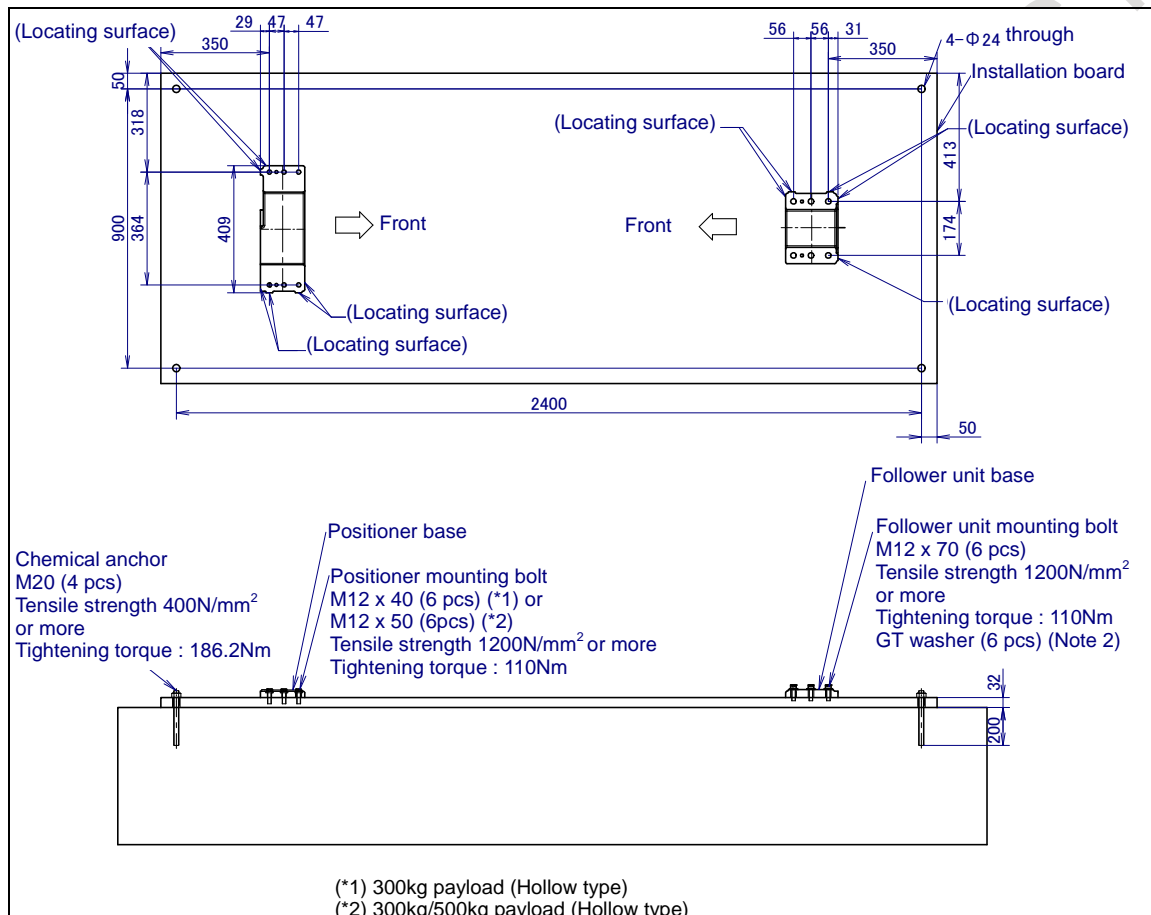

Fig. 3.3 (g) Example of installing the positioner (300kg payload (Hollow shaft)), (300kg/500kg payload (Hollow shaft)) and follower unit (insulated flange)

NOTE

- 1 Install the positioner and follower unit so that their axial centers are aligned. For the installation, follow the guidelines provided by the contractor and use a level or three-dimensional measuring instrument to ensure that the positioner and follower unit are centered.
The allowable moment for the reducer
: 2450 N·m (250 kgf·m). 300kg payload (Hollow shaft)
: 3920 N·m (400 kgf·m). 300kg/500kg payload (Hollow shaft)
Install the reducer so as not to exceed the allowable moment by placing the reducer off-center.
- 2 Be sure to use the supplied GT washers for the installation of the follower unit.
- 3 Flatness of positioner installation surface must be less than or equal to 0.5mm.
Inclination of robot installation surface must be less than or equal to 0.5° .
If positioner base is placed on uneven ground, it may result in the base breakage or low performance of the positioner.

Fig. 3.3 (h) shows an example of installing the 300kg payload (Hollow type) or 300kg/500kg payload (Hollow type) positioner and the follower unit (non-insulated flange). In this example, the floor plate is fixed with four M20 chemical anchors (Tensile strength 400N/mm^2 or more), and the positioner base is fastened to the floor plate with six M12 x 40 bolts six M12 x 50 or (Tensile strength 1200N/mm^2 or more). The follower unit base is fastened with two M20 x 50 bolts (Tensile strength 1200N/mm^2 or more). When compatibility must be maintained in teaching the positioner mechanical unit replacement, use the mounting surface.

NOTE

The customer shall arrange for the positioning pin, anchor bolts, and floor plate.

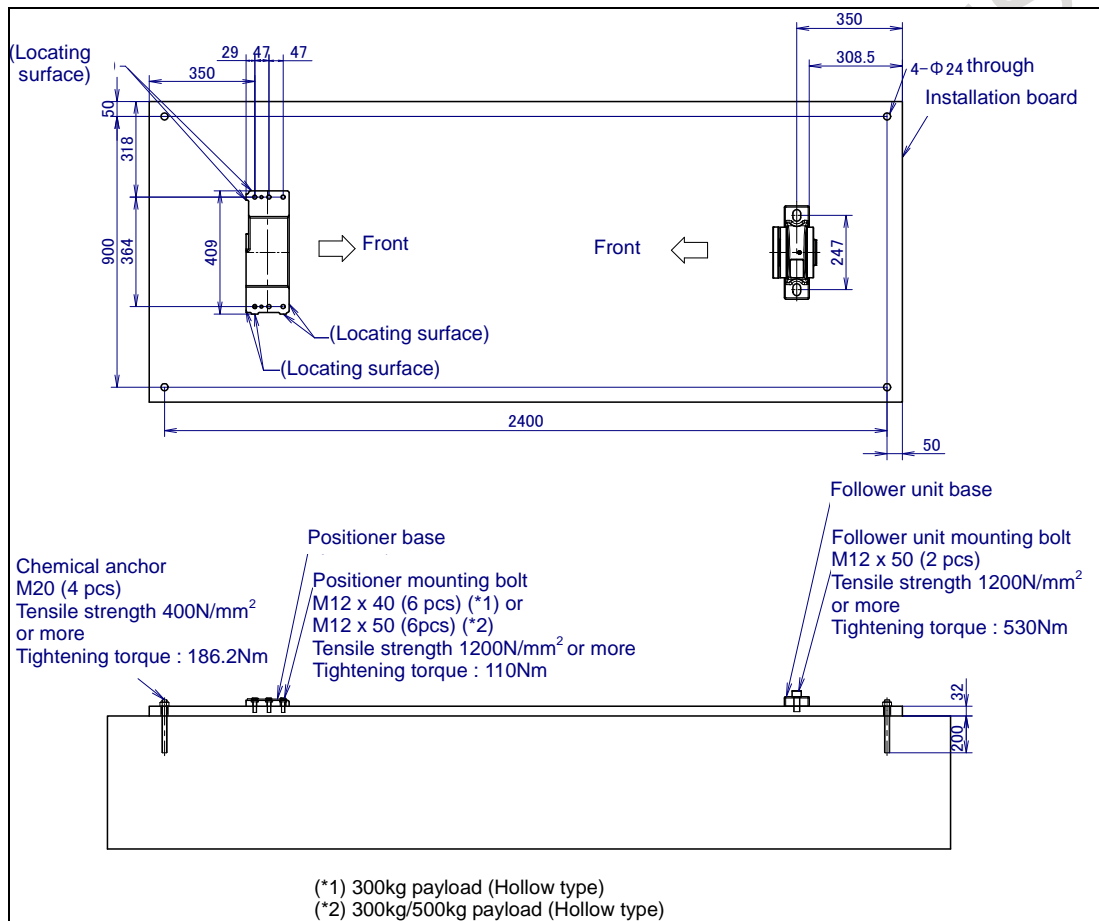

Fig. 3.3 (h) Example of installing the positioner (300kg payload (Hollow shaft)), (300kg/500kg payload (Hollow shaft)) and follower unit (non-insulated flange)

NOTE

- 1 Install the positioner and follower unit so that their axial centers are aligned. For the installation, follow the guidelines provided by the contractor and use a level or three-dimensional measuring instrument to ensure that the positioner and follower unit are centered.
The allowable moment for the reducer
: 2450 N·m (250 kgf·m). 300kg payload (Hollow shaft)
: 3920 N·m (400 kgf·m). 300kg/500kg payload (Hollow shaft)
Install the reducer so as not to exceed the allowable moment by placing the reducer off-center.
- 2 Flatness of positioner installation surface must be less than or equal to 0.5mm.
Inclination of robot installation surface must be less than or equal to 0.5° .
If positioner base is placed on uneven ground, it may result in the base breakage or low performance of the positioner.

Fig. 3.3 (i) shows an example of installing the 1000kg/1500kg payload capacity type positioner and follower unit (insulated flange).

In this example, the floor plate is fixed with four M20 chemical anchors (Tensile strength 400N/mm^2 or more), and the positioner base is fastened to the floor plate with four M20 x 40 bolts (Tensile strength 1200N/mm^2 or more). The follower unit base is fastened to the floor plate with six M12 x 70 bolts (Tensile strength 1200N/mm^2 or more). When compatibility must be maintained in teaching the positioner mechanical unit replacement, use the mounting surface.

NOTE

The customer shall arrange for the positioning pin, anchor bolts, and floor plate.

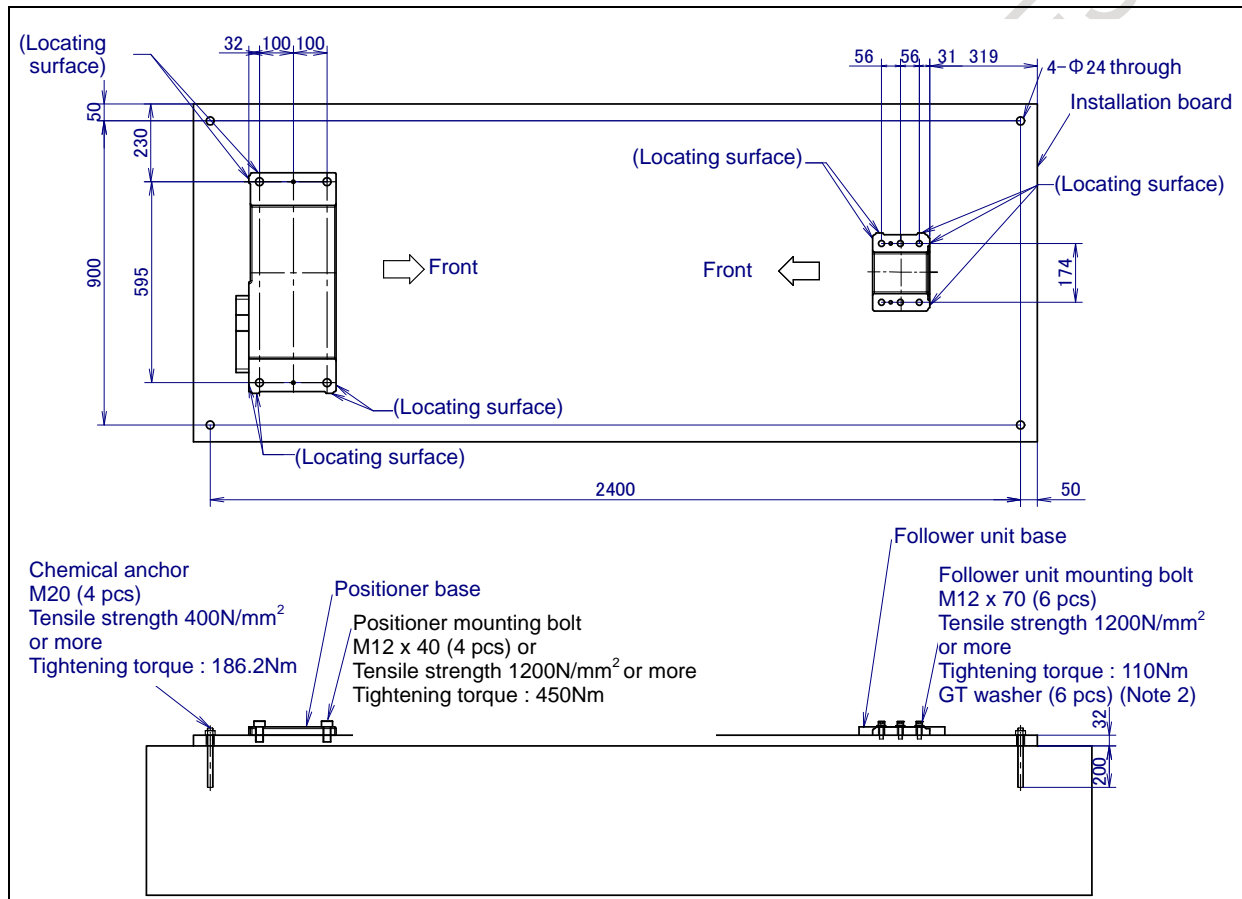

Fig. 3.3 (i) Example of installing the positioner
(When using 1000kg/1500kg payload (Hollow shaft) and follower unit (insulated flange))

NOTE

- 1 Install the positioner and follower unit so that their axial centers are aligned. For the installation, follow the guidelines provided by the contractor and use a level or three-dimensional measuring instrument to ensure that the positioner and follower unit are centered.
The allowable moment for the reducer is $20580\text{ N}\cdot\text{m}$ ($2100\text{ kgf}\cdot\text{m}$). Install the reducer so as not to exceed the allowable moment by placing the reducer off-center.
- 2 Be sure to use the supplied GT washers for the installation of the follower unit.
- 3 Flatness of positioner installation surface must be less than or equal to 0.5mm .
Inclination of robot installation surface must be less than or equal to 0.5° .
If positioner base is placed on uneven ground, it may result in the base breakage or low performance of the positioner.

Refer to Table 3.3 (a) about size of bolt, number, and tightening torque.

Table 3.3 (a) Base mounting bolts of positioner and follower unit

Model	300kg payload (Hollow type)	300kg/500kg payload (Hollow type)	1000kg/1500kg payload (Hollow type)	1000kg/1500kg payload (Compact type)	Follower unit (insulated flange)	Follower unit (non-insulated flange)
Mounting bolt	M12	M12	M20	M20	M12	M20
Q'ty	6	6	4	4	4	2
Tightening torque [Nm]	110	110	450	530	110	530

NOTE

When 1-axis servo positioner or follower unit (with insulated flange) only is used on wall mount. We recommend to use 2 parallel pins to pin holes.

When setting the positioner as the wall mount, reinforcement such as Fig. 3.3 (j) is recommended.

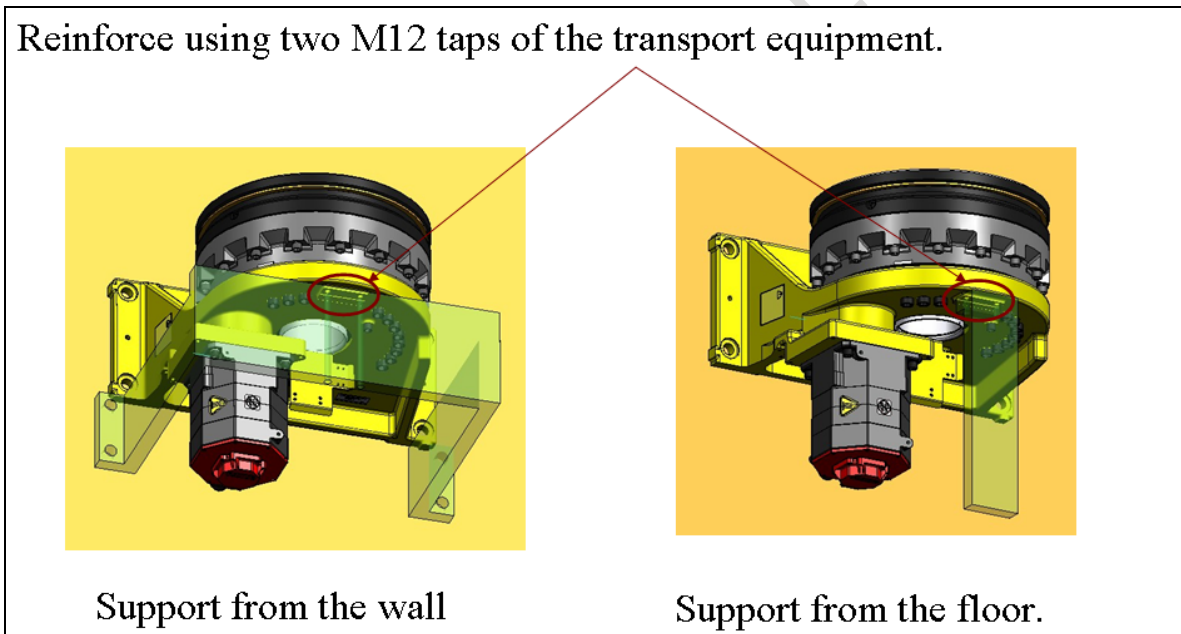

Fig. 3.3 (j) Reinforcement for the wall mount

Matching the center of 1-axis positioner and follower unit

Example of matching the center is shown below. Match the center of 1-axis positioner and follower unit referring to below.

When the parallel degree of hardness and the installation side of a footstool installing 1 axis positioner and follower unit is bad, 1 axis positioner and follower unit give off vibration and allophone at the time of driving, and it becomes the cause that you invite damage for the early stage.

- 1 Install 1-axis positioner and follower unit to common footstool and perform leveling.
- 2 Insert fixture which you can confirm hollow hole of follower unit. (See Fig.3.3 (k))
- 3 Rotate the positioner and confirm that a change of laser floodlight equal to or less than 0.5mm at 1m.
- 4 Set a projection of the light device to flange surface of drive side so that it is vertical to flange and it is near rotation center.
- 5 Rotate the positioner and adjust the position of follower side so that match the position of rotation center of light of projection of the light device and rotation center of follower side. If laser light penetrate fixture for matching position, you can confirm matching position is performed.
- 6 Move the position of fixture to the depth of hollow hole to adjust the degree of leaning. And adjust it to match the center.

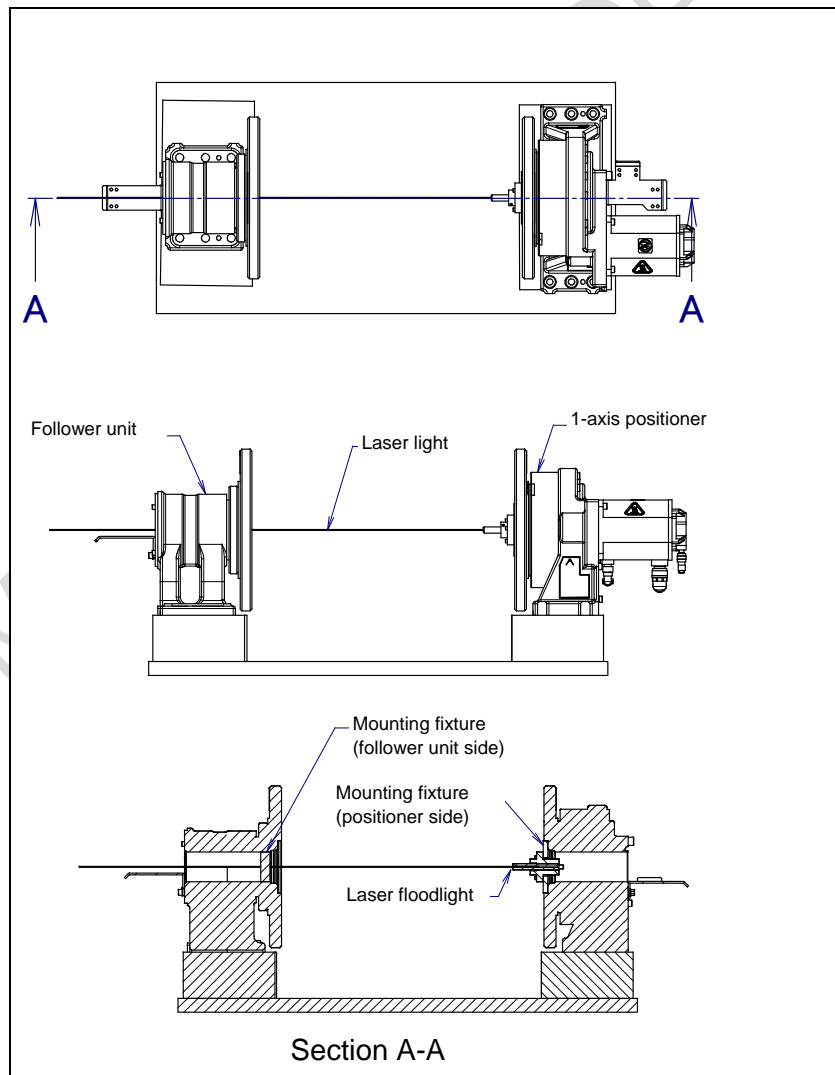

Fig. 3.3 (k) Example of matching the center of 1-axis positioner and follower unit

Assemble fixture of positioner side referring to Fig. 3.3 (l).

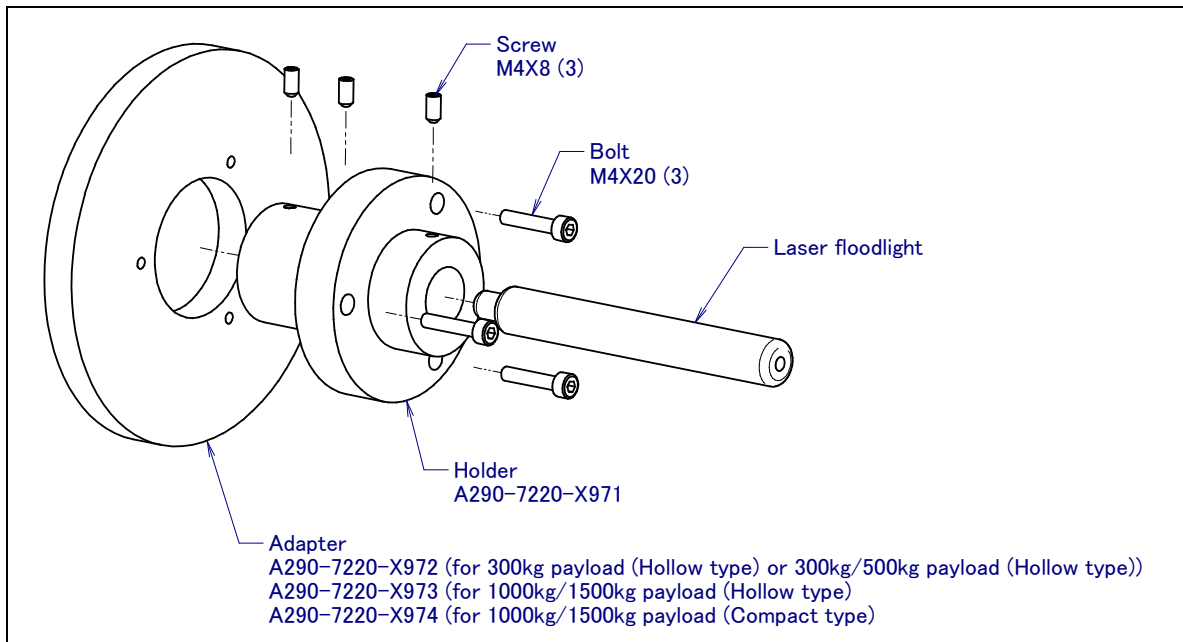

Fig. 3.3 (l) Installation of fixture of positioner side

Fig. 3.3 (m) to (r) show example of fixture for matching the center. Fixture (positioner side) is installed to a projection of the light device by insertion. Fixture (follower unit side) is installed to pipe by insertion.

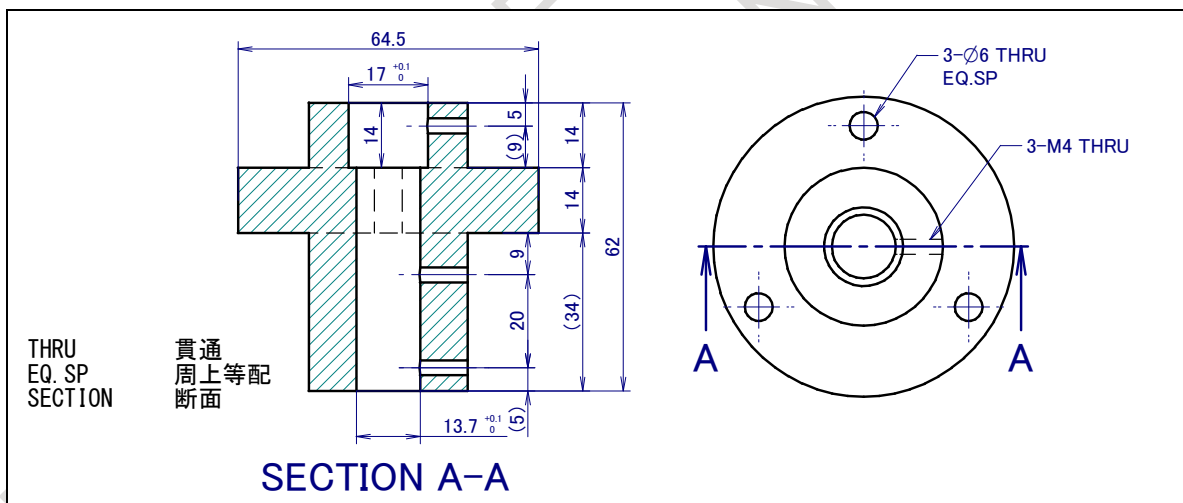

Fig. 3.3 (m) Holder (Spec: A290-7220-X971)

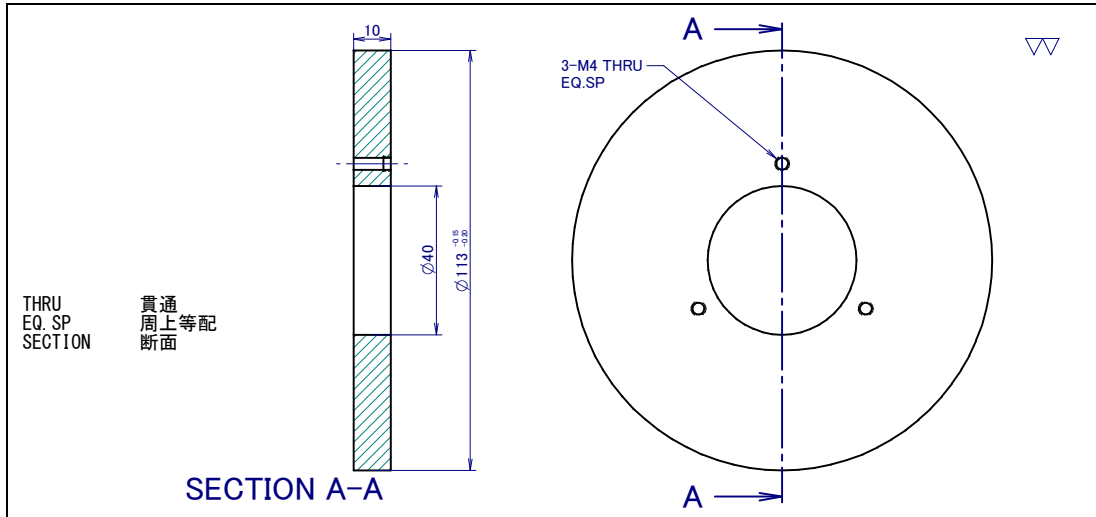

Fig. 3.3 (n) Adapter for 300kg payload (Hollow type), 300kg/500kg payload (Hollow type)
(Spec:A290-7220-X972)

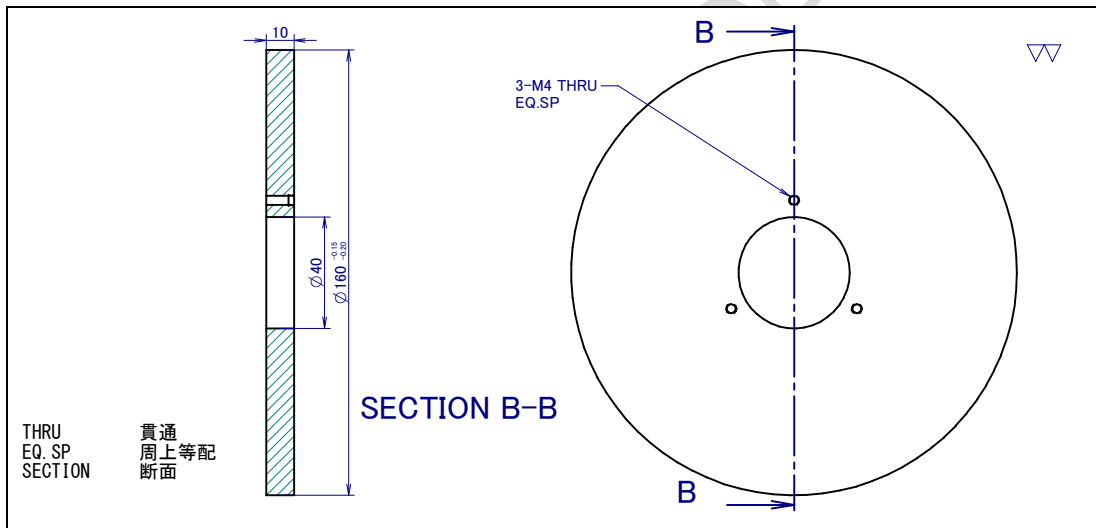

Fig. 3.3 (o) Adapter for 1000kg/1500kg payload (Hollow type) (Spec:A290-7220-X973)

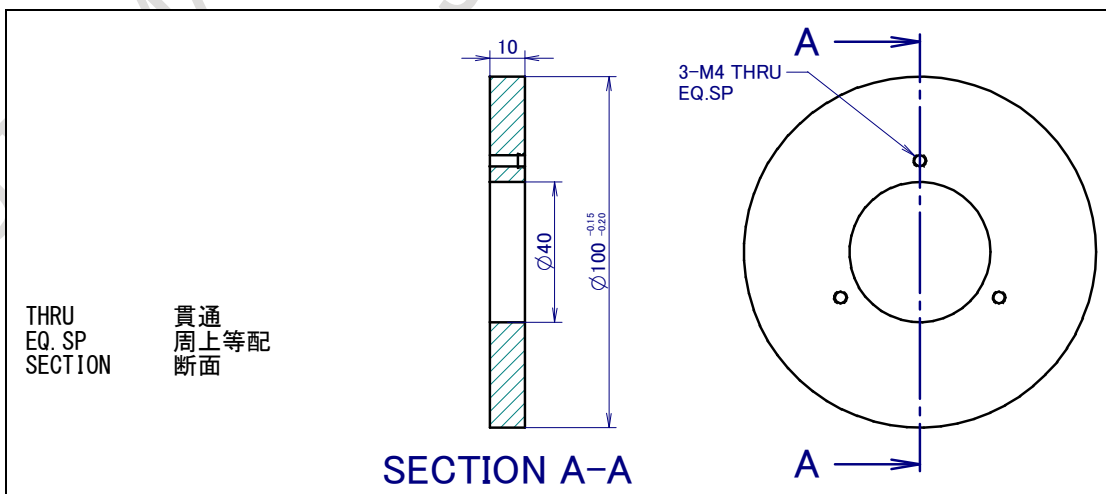

Fig. 3.3 (p) Adapter for 1000kg/1500kg payload (Compact type) (Spec:A290-7220-X974)

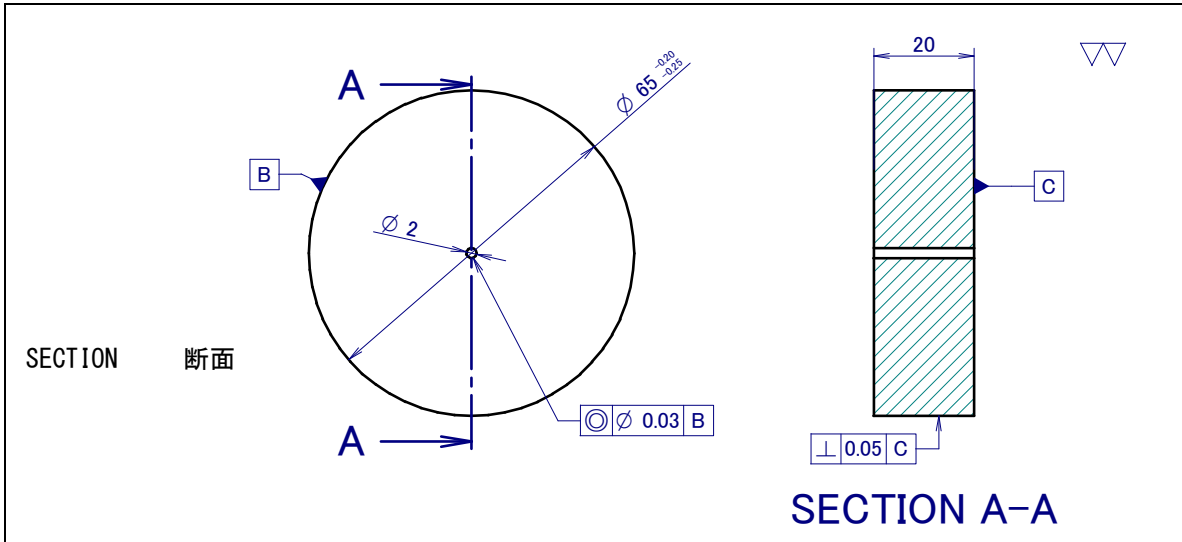

Fig. 3.3 (q) Adapter for follower unit (insulated flange) (Spec: A290-7220-X975)

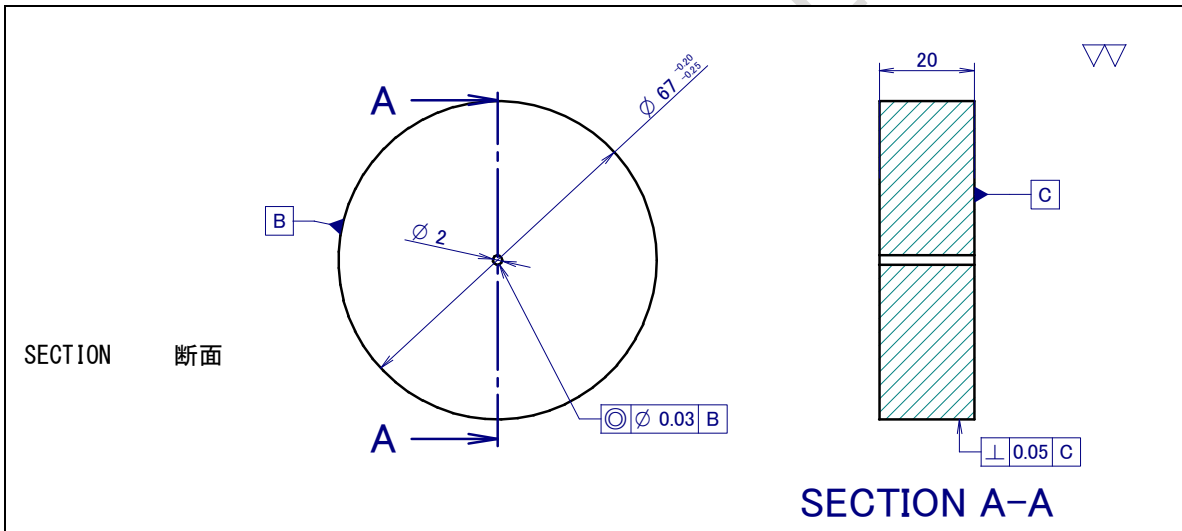

Fig. 3.3 (r) Adapter for follower unit (non-insulated flange) (Spec: A290-7220-X976)

Laser floodlight is assumed below.
LUMINE SEISAKUJYO LTD. TYPE: GLM-A2 or GLM-A3

Refer to Fig. 3.3 (s) about permissible angle of inclination of 1-axis positioner and follower unit.
If angle of inclination is more than it, it cause reduction life of 1-axis servo positioner and follower unit.

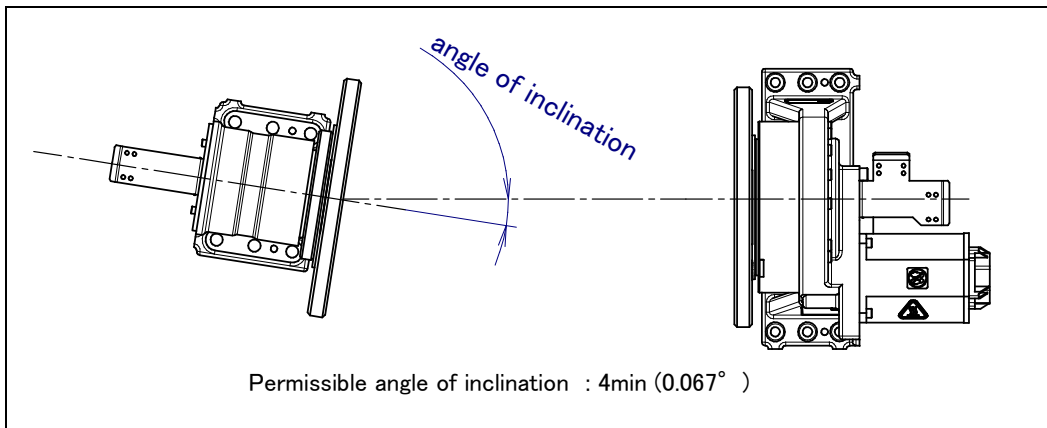

Fig. 3.3 (s) Permissible angle of inclination of positioner and follower unit

When inserting fixture to follower unit (non-insulated flange), Insert fixture after removing sleeve of the side where flange does not come with referring to 3.3 (t).

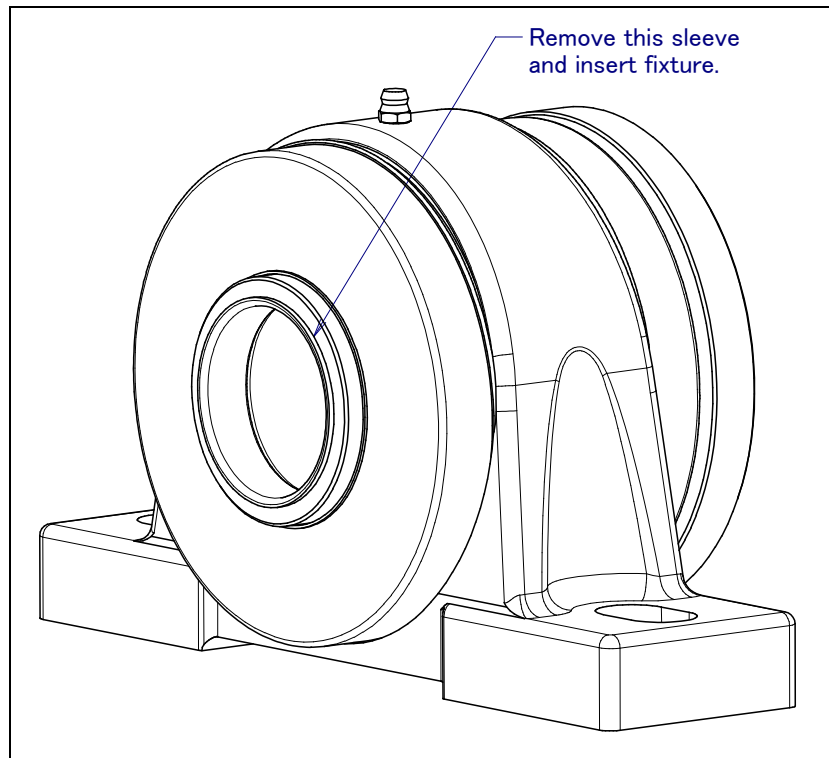

Fig. 3.3 (t) Removing the sleeve of follower unit (non-insulated flange)

Fig. 3.3 (u) and Table 3.3 (b) to (e) explain what load is put on the base when the positioner is at a rest, accelerating or decelerating, and at a Power-Off stop.

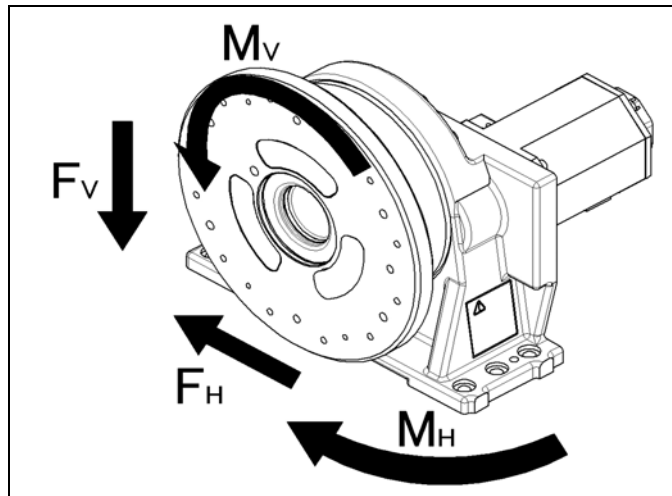

Fig. 3.3 (u) Load and moment applied to the base

Table 3.3 (b) Load and moment applied to the base 300kg payload
(300kg payload (hollow type)), (300kg/500kg payload (Hollow type))

State	MV		FV		MH		FH	
	[Kg·m]	(N·m)	[Kg]	(N)	[Kg·m]	(N·m)	[Kg]	(N)
At rest	36	353	385	3773	0	0	0	0
Accelerating or decelerating	200	1961	411	4024	24	236	26	251
At a Power-Off stop	334	3276	432	4230	44	430	47	457

Table 3.3 (c) Load and moment applied to the base 500kg payload
(300kg/500kg payload (Hollow type))

State	MV		FV		MH		FH	
	[Kg·m]	(N·m)	[Kg]	(N)	[Kg·m]	(N·m)	[Kg]	(N)
At rest	60	588	585	5733	0	0	0	0
Accelerating or decelerating	227	2221	613	6005	17	165	28	272
At a Power-Off stop	439	4300	648	6352	38	376	63	619

Table 3.3 (d) Load and moment applied to the base 1000kg payload
(1000kg/1500kg payload (Hollow type), (1000kg/1500kg payload (Compact type))

State	MV		FV		MH		FH	
	[Kg·m]	(N·m)	[Kg]	(N)	[Kg·m]	(N·m)	[Kg]	(N)
At rest	160	1568	1280	12544	0	0	0	0
Accelerating or decelerating	407	3989	1365	13377	193	1891	85	833
At a Power-Off stop	741	7262	1481	14514	455	4459	201	1970

Table 3.3 (e) Load and moment applied to the base 1500kg payload
(1000kg/1500kg payload (Hollow type), (1000kg/1500kg payload (Compact type))

State	MV		FV		MH		FH	
	[Kg·m]	(N·m)	[Kg]	(N)	[Kg·m]	(N·m)	[Kg]	(N)
At rest	200	1960	1585	15533	0	0	0	0
Accelerating or decelerating	384	3760	1638	16057	15	143	53	524
At a Power-Off stop	700	6858	1731	16961	40	391	146	1428

3.4 MAINTENANCE CLEARANCE

Fig. 3.4 (a) and (b) show the layout of maintenance clearances.

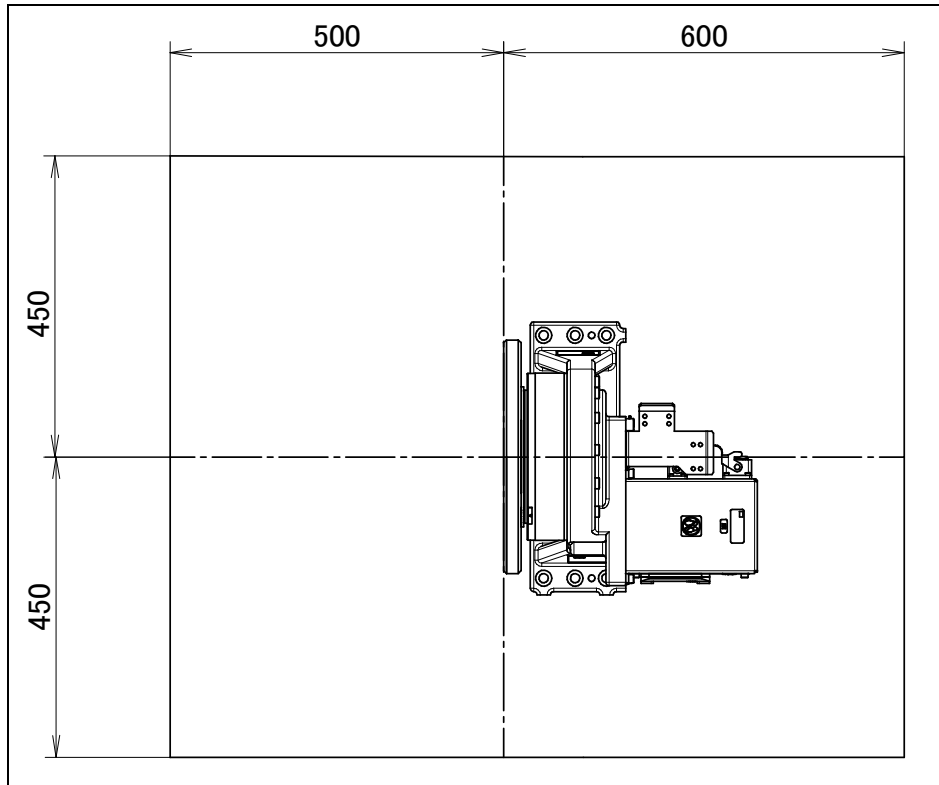

Fig. 3.4 (a) Maintenance clearance layout
(300kg payload (Hollow type)), (300kg/500kg payload (Hollow type)),
(1000kg/1500kg load capacity (Compact type))

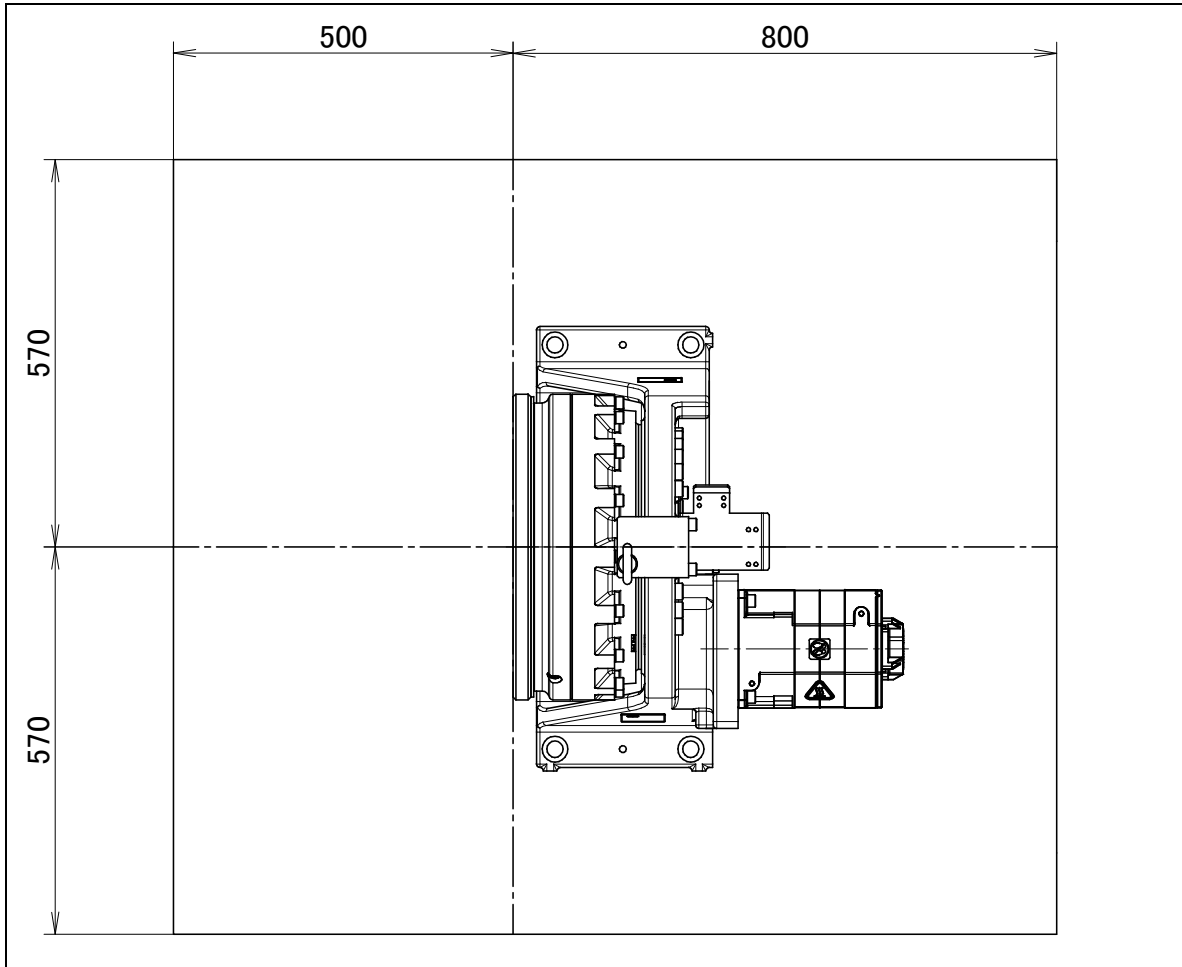

Fig. 3.4 (b) Maintenance clearance layout (1000kg/1500kg payload (Hollow type))

JR AUTOMATION JDOM

3.5 ASSEMBLING THE POSITIONER FOR INSTALLATION

The robot connection cables are detached from the mechanical unit when the robot is shipped (the cables are connected on the controller side). When the HARTING connector option is not selected, directly connect the cable for direct motor connection to the motor connector.

When the HARTING connector option is selected, connect the cables shown in Fig. 3.5 to the connector box of the mechanical unit. During the connection, take care not to pull the HARTING connector cable.

In connecting cables between the robot controller and the positioner body, the customer needs to obtain cable ducts or the like.

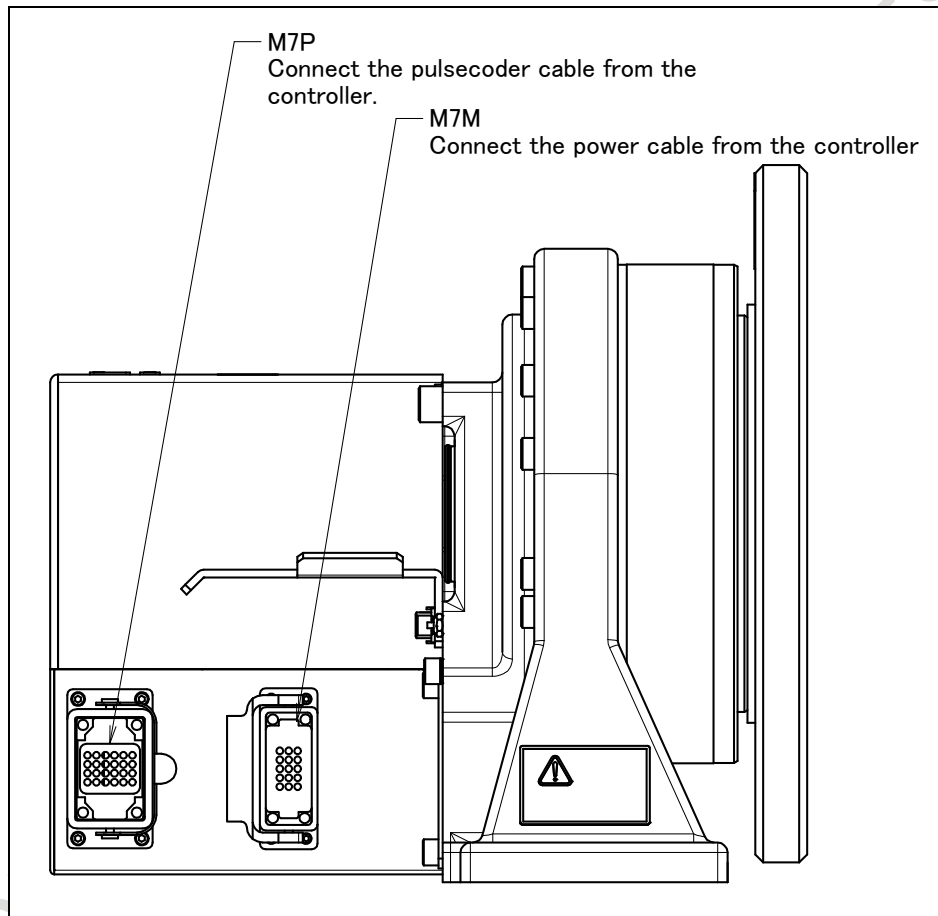

Fig. 3.5 Cable connection panel for the positioner mechanical unit

3.6 INSTALLATION CONDITIONS

Refer to Specification of [PREFACE] about installation conditions.

APPENDIX

JR AUTOMATION TECHNOLOGIES INC*
JDOWLING

JR AUTOMATION TECHNOLOGIES INC*
JDOWLING

A MAINTENANCE PARTS

Table A (a) Cables (When the HARTING connector option is selected.)

Cable No.	Specifications	Remarks	Load capacity
K101	A660-8016-T096	Pulsecoder	300kg payload (Hollow type) 300kg/500kg payload (Hollow type)
K102	A660-8016-T097	Motor power, brake	300kg payload (Hollow type) 300kg/500kg payload (Hollow type)
K101	A660-8016-T241	Pulsecoder	1000kg/1500kg payload (Hollow type)
K102	A660-8016-T243	Motor power, brake	1000kg/1500kg payload (Hollow type)
K101	A660-8017-T441	Pulsecoder	1000kg/1500kg payload (Compact type)
K102	A660-8017-T442	Motor power, brake	1000kg/1500kg payload (Compact type)

Table A (b) Motor

Specifications	Model	Load capacity
A06B-0235-B605#S000 (*1)	α iS8/4000	300kg payload (Hollow type) 300kg/500kg payload (Hollow type)
A06B-2235-B605 (*2)		
A06B-0265-B605#S000	α iS22/4000	1000kg/1500kg payload (Hollow type) 1000kg/1500kg payload (Compact type)

NOTE

Both motors (*1) (*2) can be used. However, we recommend (*2) when ordering motors.

Table A (c) Reducer

Specifications	Weight	Load capacity
A97L-0218-0805#37	20kg	300kg payload (Hollow type)
A97L-0218-0819	91kg	1000kg/1500kg payload (Hollow type)
A97L-0218-0891#37	20kg	300kg/500kg payload (Hollow type)
A97L-0218-0889#171	45kg	1000kg/1500kg payload (Compact type)

Table A (d) Gear

Specifications	Name	Load capacity
A290-7216-X212	Center gear	300kg payload (Hollow type) 300kg/500kg payload (Hollow type)
A290-7220-X111	Gear	300kg payload (Hollow type)
A290-7220-X151	Gear	1000kg/1500kg payload (Compact type)
A290-7220-Z111	Gear	300kg/500kg payload (Hollow type)

Table A (e) Insulator, collar

Specifications	Name	Q'ty	Use position	Model
A290-7220-X325	Insulator	3	Flange	300kg payload (Hollow type)
A98L-0040-0211#121512	Collar	9	Flange	300kg payload (Hollow type)
A290-7220-X326	Cover	3	Flange	300kg payload (Hollow type)
A98L-0040-0211#121512	Insulator A	18	Flange	1000kg/1500kg payload (Hollow type)
A98L-0040-0222#30152	Insulator B	18	Flange	1000kg/1500kg payload (Hollow type)
A290-7220-X144	Cover	18	Flange	1000kg/1500kg payload (Hollow type)
A290-7220-Z325	Insulator	3	Flange	300kg/500kg payload (Hollow type)
A98L-0040-0211#121512	Collar	12	Flange	300kg/500kg payload (Hollow type)
A290-7220-Z326	Cover	3	Flange	300kg/500kg payload (Hollow type)
A98L-0040-0212#081215	Collar	2	Ground brush	Infinite continuous turn mechanical option

Table A (f) Bearing

Specifications	Load capacity
A97L-0001-0192#1600000	300kg/500kg payload (Hollow type)
A97L-0001-0195#06Z000A	300kg payload (Hollow type)
A97L-0001-0196#09Z000A	1000kg/1500kg payload (Hollow type)
A97L-0218-0903#6306R	300kg/500kg payload (Hollow type)

Table A (g) O ring

Specifications	Use position	Load capacity
JB-OR1A-G105	Motor	300kg payload (Hollow type) 300kg/500kg payload (Hollow type)
JB-OR1A-G95	Pipe	300kg payload (Hollow type) 300kg/500kg payload (Hollow type)
A98L-0040-0041#173	Reducer	300kg payload (Hollow type) 300kg/500kg payload (Hollow type)
JB-OR1A-G125	Motor, pipe	1000kg/1500kg payload (Hollow type) 300kg/500kg payload (Hollow type) 1000kg/1500kg payload (Compact type)
A98L-0040-0041#281	Reducer	1000kg/1500kg payload (Hollow type)
JB-OR1A-G270	Reducer	1000kg/1500kg payload (Compact type)

Table A (h) Oil seal

Specifications	Use position	Load capacity
A98L-0040-0047#07010014	Pipe	300kg payload (Hollow type) 300kg/500kg payload (Hollow type)
A98L-0040-0047#13016014	Pipe	1000kg/1500kg payload (Hollow type)

Table A (i) Grease

Parts name	Specifications	Remarks	
Grease	A98L-0040-0174#16KG	Kyodo Yushi VIGOGREASE RE0 (16kg in can) Refer to Section 3.1 of MAINTENANCE for required grease amount.	300kg payload (Hollow type) 300kg/500kg payload (Hollow type) 1000kg/1500kg payload (Compact type) 1000kg/1500kg payload (Hollow type)
Grease	A98L-0040-0262	Multemp ELP	Infinite continuous turn mechanical option

Table A (j) Grease nipple

Specifications	Name
A97L-0218-0013#A110	Grease nipple (1/8)

Table A (k) Seal bolt, taper plug

Parts name	Specifications	Use position
Seal bolt	A97L-0218-0417#121515	Outlet 2 (300kg payload (Hollow type)) (300kg/500kg payload (Hollow type)) Outlet 1,2 (1000kg/1500kg payload (Hollow type))
Taper plug	A97L-0001-0436#2-1D	Outlet 1 (300kg payload (Hollow type)) (300kg/500kg payload (Hollow type)) Inlet, Outlet (1000kg/1500kg payload (Compact type))

NOTE

For the locations of outlet 1 and 2, see I.MAINTENANCE 3.1.

Table A (l) Battery

Specifications	Name	Q'ty
A98L-0031-0005	1.5V (alkali), size D	4 pcs

Table A (m) Others

Specifications	Name	Model
A290-7220-V825	Ground brush	Infinite continuous turn Mechanical option
A97L-0218-0908	Auto grease cup	Infinite continuous turn Mechanical option

B MECHANICAL UNIT CIRCUIT DIAGRAMS

Fig. B shows the circuit in the mechanical unit when the HARTING connector option is selected. When the option is not selected, a direct connection is established from the motor.

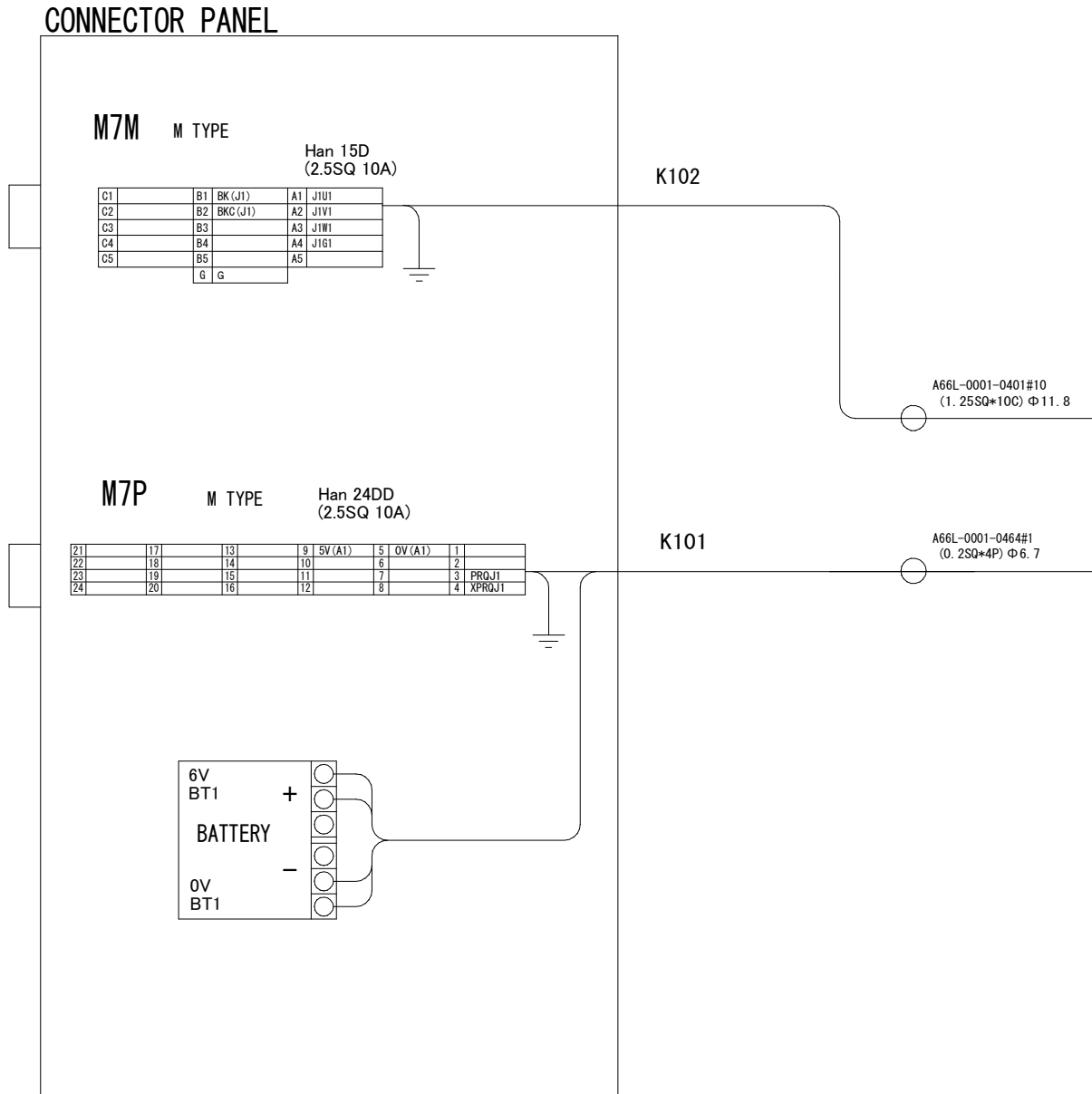
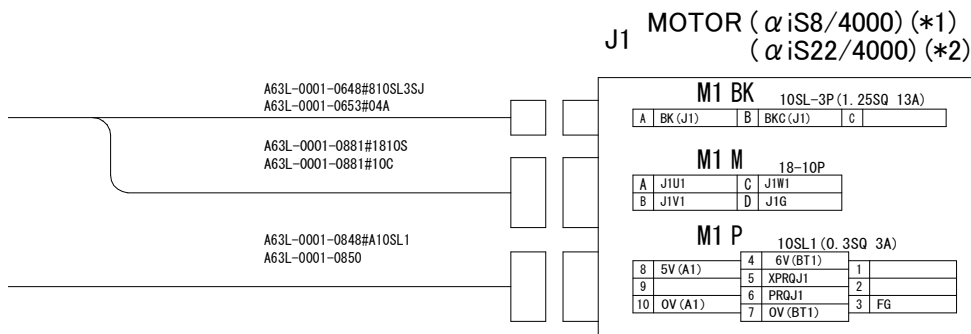

Fig. B Connection diagram



- (*1) 300kg payload 1-axis Servo Positioner (Hollow type) or
300kg/500kg payload 1-axis Servo Positioner (Hollow type)
(*2) 1000kg/1500kg payload 1-axis Servo Positioner (Hollow type) or
1000kg/1500kg payload 1-axis Servo Positioner (Compact type)

1-axis Servo Positioner

○ : MOVABLE

JR A'

C PERIODIC INSPECTION TABLE

FANUC 1-axis SERVO POSITIONER PERIODIC MAINTENANCE TABLE

Accumulated operating time (H)		Check time	Grease amount	First check	3 months	6 months	9 months	1 year				2 years					
				320	960	1920	2880	3840	4800	5760	6720	7680	8640	9600	10560		
Mechanical unit	1	Supply conductive grease (NOTE 1)	0.1H	Proper quantity	○	○	○	○	○	○	○	○	○	○	○	○	
	2	Check the abrasions of the ground brush (NOTE 1)	0.1H	—	○	○	○	○	○	○	○	○	○	○	○	○	○
	3	Check for external damage or peeling paint	0.1H	—		○	○	○	○	○	○	○	○	○	○	○	○
	4	Check for water	0.1H	—		○	○	○	○	○	○	○	○	○	○	○	○
	5	Check the exposed connector (tightness). (NOTE 2)	0.2H	—		○			○			○					
	6	Check the motor connector (tightness).	0.2H	—		○			○			○					
	7	Tighten the flange mounting bolts, cover mounting bolts, and main bolts	0.7H	—		○			○			○					
	8	Clean spatters, sawdust and dust	1.0H	—		○			○			○					
	9	Replacing battery. (NOTE 3)	0.1H	—							●						
	10	Replacing grease of reducer. 300kg payload (Hollow type) 300kg/500kg payload (Hollow type) (NOTE 4)	0.3H	980ml													
Replacing grease of reducer. 1000kg/1500kg payload (Hollow type) (NOTE 4)		1.0H	5500ml														
Replacing grease of reducer. 1000kg/1500kg payload (Compact type) (NOTE 4)		0.3H	1193ml														
Controller	11	Check the robot cable, teach pendant cable and robot connecting cable	0.2H			○			○			○					
	12	Cleaning the controller ventilation system (NOTE 5)	0.2H		○	○	○	○	○	○	○	○	○	○	○	○	○
	13	Replacing battery (NOTE 6)	0.1H														

NOTE 1) When Infinite continuous turn mechanical option for 300kg/500kg (Hollow type) is specified. Check them once every one-month.

NOTE 2) Check this when Harting connector option is selected. The cycle of replacing is necessary to be shortened. Refer to MAINTENANCE 8 in replacing the cable.

NOTE 3) Refer to the manual MAINTENANCE 3.3.

NOTE 4) Refer to Fig. 3.1 (a) and (b) of the Section 3.1 in MAINTENANCE.

NOTE 5) Clean the positioner properly in case of using the positioner under much dust existing.

NOTE 6) Refer to the “REPLACING UNITS Chapter of MAINTENANCE” in the following manuals.

R-30iB/R-30iB Plus CONTROLLER MAINTENANCE MANUAL (B-83195EN) etc

●: requires order of parts

○: does not require order of parts

3 years 11520	12480	13440	14400	4 years 15360	16320	17280	18240	5 years 19200	20160	21120	22080	6 years 23040	24000	24960	25920	7 years 26880	27840	28800	29760	8 years 30720	Items
○	○	○	○	○	○	○	○	○	○	○	○	○	○	○	○	○	○	○	○	○	1
○	○	○	○	○	○	○	○	○	○	○	○	○	○	○	○	○	○	○	○	○	2
○	○	○	○	○	○	○	○	○	○	○	○	○	○	○	○	○	○	○	○	○	3
○	○	○	○	○	○	○	○	○	○	○	○	○	○	○	○	○	○	○	○	○	4
○				○				○				○				○					5
○				○				○				○				○					6
○				○				○				○				○					7
○				○				○				○				○					8
●						●						●						●			9
●												●									10
●												●									
●												●									
●												●									
○				○				○				○				○					11
○	○	○	○	○	○	○	○	○	○	○	○	○	○	○	○	○	○	○	○	○	12
				●																	13

D STRENGTH OF BOLT AND BOLT TORQUE LIST

NOTE

When applying LOCTITE to a part, spread the LOCTITE on the entire length of the engaging part of the female thread. If applied to the male threads, poor adhesion can occur, potentially loosening the bolt. Clean the bolts and the threaded holes and wipe off any oil on the engaging section. Make sure that there is no solvent left in the threaded holes. When finished, remove all the excess LOCTITE when you are finished screwing the bolts into the threaded holes.

Use the following strength bolts. Comply with any bolt specification instructions.

Hexagon socket head bolt made of steel:

Size M22 or less: Tensile strength 1200N/mm² or more

Size M24 or more: Tensile strength 1000N/mm² or more

All size plating bolt: Tensile strength 1000N/mm² or more

Hexagon bolt, stainless bolt, special shape bolt (button bolt, low-head bolt, flush bolt .etc.)

Tensile strength 400N/mm² or more

Refer to the following tables if the bolts tightening torque is not specified.

Recommended bolt tightening torques

Unit: Nm

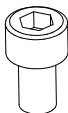
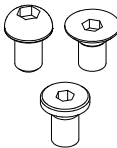
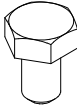
Nominal diameter	Hexagon socket head bolt (steel)		Hexagon socket head bolt (stainless)		Hexagon socket head button bolt Hexagon socket head flush bolt Low-head bolt (steel)		Hexagon bolt (steel)	
	Tightening torque		Tightening torque		Tightening torque		Tightening torque	
	Upper limit	Lower limit	Upper limit	Lower limit	Upper limit	Lower limit	Upper limit	Lower limit
M3	1.8	1.3	0.76	0.53	—	—	—	—
M4	4.0	2.8	1.8	1.3	1.8	1.3	1.7	1.2
M5	7.9	5.6	3.4	2.5	4.0	2.8	3.2	2.3
M6	14	9.6	5.8	4.1	7.9	5.6	5.5	3.8
M8	32	23	14	9.8	14	9.6	13	9.3
M10	66	46	27	19	32	23	26	19
M12	110	78	48	33	—	—	45	31
(M14)	180	130	76	53	—	—	73	51
M16	270	190	120	82	—	—	98	69
(M18)	380	260	160	110	—	—	140	96
M20	530	370	230	160	—	—	190	130
(M22)	730	510	—	—	—	—	—	—
M24	930	650	—	—	—	—	—	—
(M27)	1400	960	—	—	—	—	—	—
M30	1800	1300	—	—	—	—	—	—
M36	3200	2300	—	—	—	—	—	—
								

INDEX

<A>		<O>	
ADJUSTMENTS	27	OUTLINE DRAWING	73
ASSEMBLING THE POSITIONER FOR INSTALLATION	104	<P>	
		Periodic Check and Maintenance	5
BACKLASH MEASUREMENT	25	PERIODIC INSPECTION TABLE	112
BATTERY REPLACEMENT	15	PERIODIC MAINTENANCE	4,12
<C>		PIPING AND WIRING	64
CABLE REPLACEMENT	65	POSITIONER LOAD CONDITION	76
CABLING (WHEN THE HARTING CONNECTOR OPTION IS SELECTED)	64	POSITIONER OUTLINE DRAWING	73
CHANGING METHOD OF PAYLOAD SPECIFICATION	80	PREFACE	p-1
CHECK POINTS	7	PROCEDURE FOR RELEASING THE GREASE REMAINING PREESSURE	14
CHECKS AND MAINTENANCE	4	<Q>	
COMPONENT REPLACEMENT AND ADJUSTMENT ITEMS	26	Quick Mastering	41
CONFIGURATION	3	QUICK MASTERING FOR SINGLE AXIS	43
Confirmation of Oil Seepage	9	<R>	
Confirmation of the Air Control Set	10	REFERENCE POSITION AND MOVING RANGE ...	27
<D>		REPLACING CABLES	66
Daily Checks	4	REPLACING PARTS	51
<F>		REPLACING THE GROUND BRUSH (for 300kg/500kg payload (Hollow type) Infinite continuous turn mechanical option)	62
Fixture Position Master	30	REPLACING THE MOTOR	52
<G>		REPLACING THE REDUCER	56
GREASE REPLACEMENT	12	REPLACING THE ROTARY JOINT (for 300kg/500kg payload (Hollow type) Infinite continuous turn mechanical option)	63
GREASING (for 300kg/500kg payload (Hollow type) Infinite continuous turn mechanical option)	17	Resetting Alarms and Preparing for Mastering	29
</>		<S>	
In the case of 1000 kg/1500kg payload (Compact type)	55,59	SAFETY PRECAUTIONS	s-1
In the case of 1000 kg/1500kg payload (Hollow type) ..	58	SEALANT APPLICATION (1000kg/1500kg payload (Hollow type)) (1000kg/1500kg payload (Compact type))	60
In the case of 1000kg/1500kg payload (Hollow type) ...	54	Single Axis Mastering	45
In the case of 300kg payload (Hollow type), 300kg/500kg payload (Hollow type)	52,56	STORING THE POSITIONER	88
INSTALLATION	89	STRENGTH OF BOLT AND BOLT TORQUE LIST	114
INSTALLATION CONDITIONS	104	Supply conductive grease, check the abrasion of the ground brush (for 300kg/500kg payload (Hollow type) Infinite continuous turn mechanical option)	7
<M>		<T>	
MAINTENANCE CLEARANCE	102	TRANSPORTATION	86
MAINTENANCE PARTS	107	TRANSPORTATION AND INSTALLATION	86
MAINTENANCE TOOLS	11	TROUBLESHOOTING	18
MASTERING	28	<V>	
Mastering Data Entry	48	VERIFYING MASTERING	50
MECHANICAL UNIT CIRCUIT DIAGRAMS	110	<Z>	
Method of executing KAREL program by using "Call program"	81	Zero Position Mastering	38
Method of executing KAREL program directly	84		
MOUNTING DEVICES ON THE POSITIONER	76		

JR AUTOMATION TECHNOLOGIES INC*
JDOWLING

REVISION RECORD

Edition	Date	Contents
06	Aug., 2017	<ul style="list-style-type: none"> • Addition of R-30iB Plus/R-30iB Mate Plus controller • Correction of mistakes
05	Jun., 2014	<ul style="list-style-type: none"> • Addition of R-30iB/R-30iB Mate controller • Addition of the Infinite continuous turn mechanical option • Correction of mistakes
04	Dec., 2011	<ul style="list-style-type: none"> • Addition of note about installation • Correction of mistakes
03	Oct., 2010	<ul style="list-style-type: none"> • Addition of 300kg/500kg payload (Hollow type) • Addition of 1000kg/1500kg payload (Compact type) • Change 1000kg load capacity to of 1000kg/1500kg payload (Hollow type) • Correction of mistakes
02	July, 2007	<ul style="list-style-type: none"> • Addition of 1000kg load capacity
01	May, 2007	

JR AUTOMATION TECHNOLOGIES INC*
JDOWLING

B-82545EN/06



* B - 8 2 5 4 5 E N / 0 6 *