

YASKAWA

SIGMA TRAC II

LINEAR MOTION MADE EASY

IT'S PERSONAL

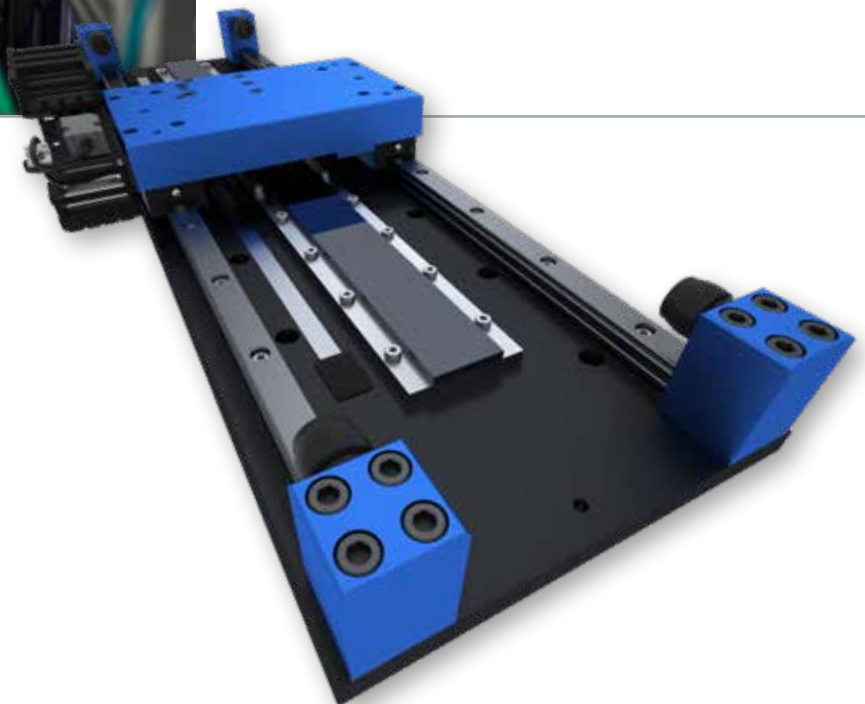

HARDWARE FEATURES

READY TO RUN

Turnkey linear stages, built-to-order and fully tested. Bolt it down, connect it up, and enjoy world class linear motion immediately.

FASTER MOTION, FASTER TIME TO MARKET

Need precise, high speed and repeatable linear motion, without the time-consuming process of designing your own linear stages?

Use Yaskawa's motion engineering expertise to spare your overworked engineers the effort of specifying, designing and sourcing components, assembly jigs, and test equipment.

Our expertly designed, manufactured, and tested mechatronic solutions give your machine a faster time to market and your engineering team more time to innovate.

SigmaTRAC II

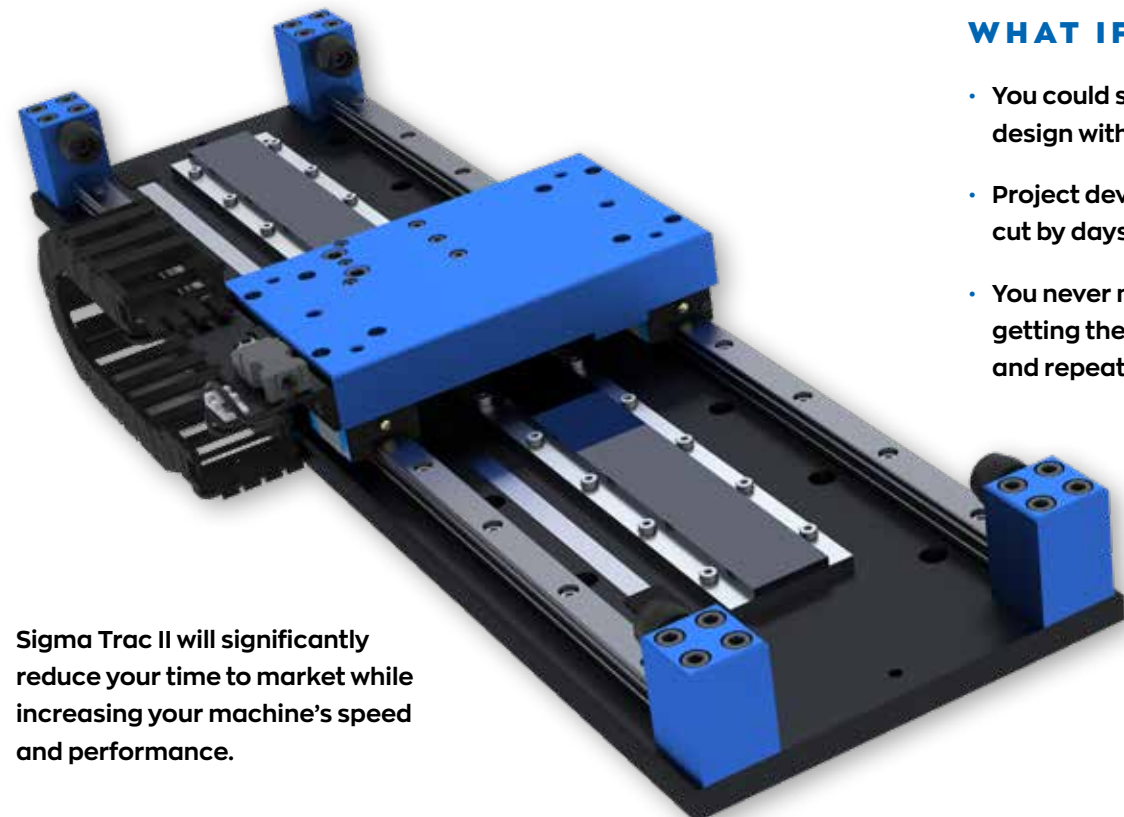

Sigma Trac II will significantly reduce your time to market while increasing your machine's speed and performance.

WHAT IF...

- You could simplify your machine's design with a bolt-in linear solution?
- Project development time could be cut by days or weeks?
- You never needed to worry about getting the best in speed, reliability, and repeatability?

COMPLETE LINEAR MOTION SOLUTION

Each component in Sigma Trac II is fully assembled and tested:

- Coil and magnets
- Bearings
- Encoder
- Cables
- Cable management
- Optional bellows
- Optional X-Y mounting kit

Simply provide a flat mounting surface and bolt on your payload.

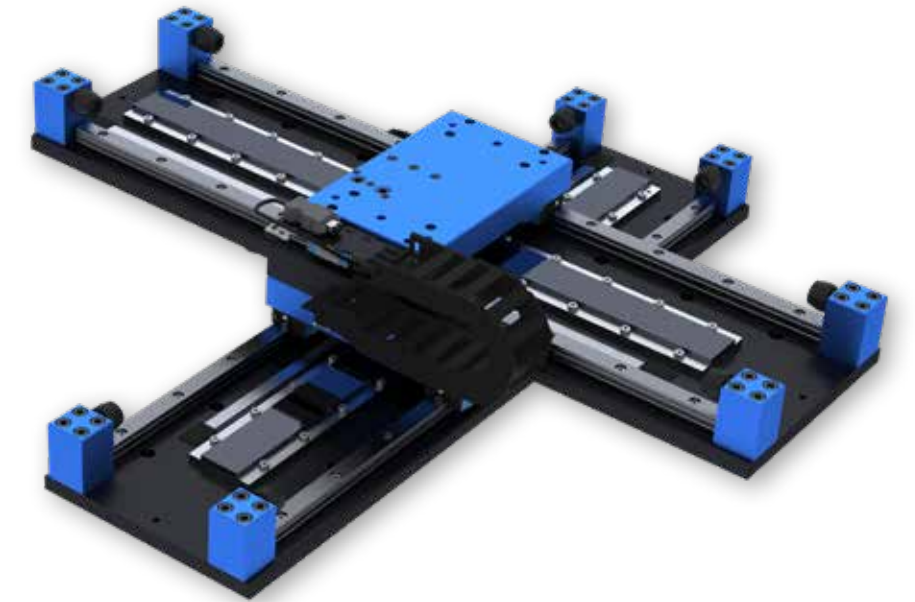

X-Y MOUNTING KIT

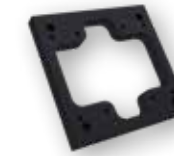

An available X-Y mounting kit simplifies design, installation of 2-axis Cartesian systems for pick and place, machining, and additive manufacturing operations

IMPROVE MACHINE PERFORMANCE



Minimize cycle times and maximize productivity with speeds up to 5m/s, and peak force output up to 5040 N.

REPEATABILITY



Coupling the load directly to the motor and encoder yields positioning repeatability of $\pm 2 \mu\text{m}$.

WIDE RANGE OF SIZES

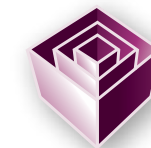

With six motor sizes and 24 base lengths, there is a linear stage for nearly any application. Stages are available for use with 100 V, 200 V, or 400 V power.

RELIABILITY



We've eliminate gears, belts, and screws, resulting in a 10 million double-stroke design life

ABSOLUTE ENCODER FEEDBACK



Simplifies wiring and requires no homing routines, even after removing power from the equipment

ZERO MAINTENANCE



Integrated bearing lubrication technology for long-term maintenance-free operation.

CABLE MANAGEMENT



Carefully controlling cable flex maximizes cable life. Use additional space in the cable carrier for cables and hoses to your payload

BELLOWS



Optional bellows protect magnets and encoder scale from dust, loose debris, and the occasional dropped tool

PRODUCT DATA

MODEL DESIGNATIONS

SIGMA TRAC II LINEAR STAGE

ST2 F - A1 A 1375 - A 1 L B

Product Series	
Σ-7 Series Linear Stage	

Motor Type	
Code	Specification
F	SGLF2 Iron Core

Motor Size	
Code	Specification
A1	SGLF2-30□070
A2	SGLF2-30□120
A3	SGLF2-30□230
C1	SGLF2-90□200
C2	SGLF2-90□380
C3	SGLF2-90□560

Voltage	
Code	Specification
A	200V
D	400V

Brake and Bellows	
Code	Specification
B	Without Brake, With Bellows
N	Without Brake, Without Bellows
K	With Brake, With Bellows
Q	With Brake, Without Bellows

Cable Carrier	
Code	Specification
L	Left Side
R	Right Side

Feedback Device	
Code	Specification
1	Fagor Optical Absolute (9.765 nm)
2	Heidenhain Optical Absolute (5 nm)
9	Heidenhain EnDat 2.2 Optical Absolute (5 nm)

Base Plate	
Code	Specification
A	Standard Base Plate
B	Thick Base Plate

Base Length			
SGLF2-30 Models		SGLF2-90 Models	
Code	Specification	Code	Specification
0390	390 mm	0800	800 mm
0565	565 mm	0900	900 mm
0655	655 mm	1000	1000 mm
0745	745 mm	1105	1105 mm
0835	835 mm	1205	1205 mm
0925	925 mm	1310	1310 mm
1015	1015 mm	1410	1410 mm
1105	1105 mm	1510	1510 mm
1195	1195 mm	1615	1615 mm
1285	1285 mm	1715	1715 mm
1375	1375 mm	1815	1815 mm
1465	1465 mm	1920	1920 mm
1555	1555 mm		

BELLOWS VARIATIONS

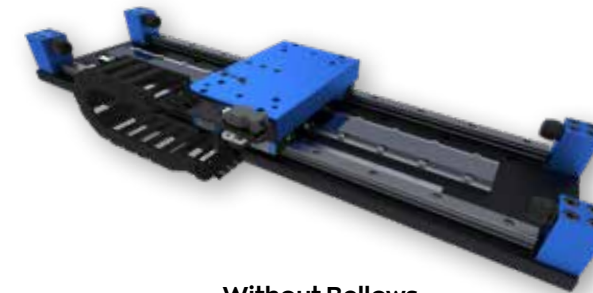

Without Bellows



With Bellows

CABLE CARRIER VARIATIONS

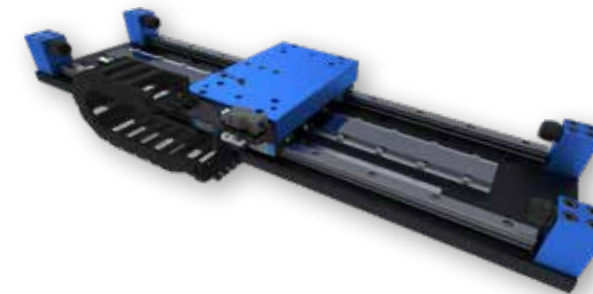

Left Side Cable Carrier

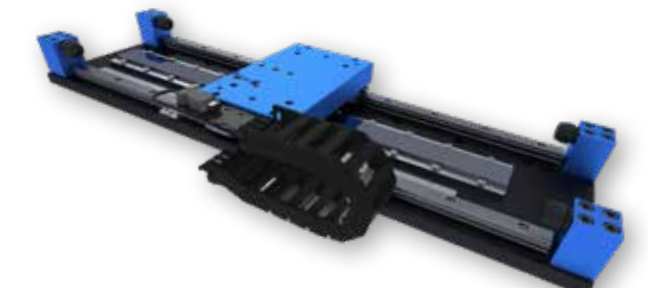

Right Side Cable Carrier

BASE PLATE VARIATIONS

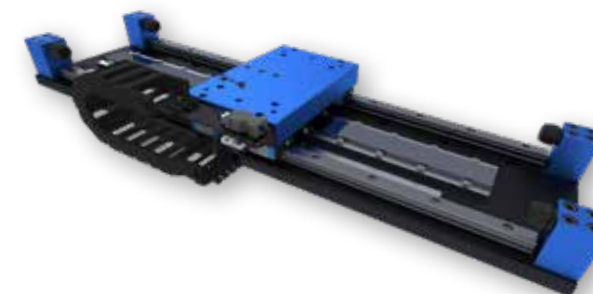

Standard Base Plate

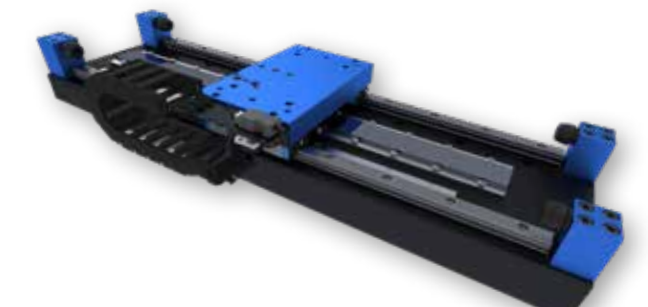

Thick Base Plate

This information is provided to explain model numbers. It is not meant to imply that models are available for all combinations of codes.

PRODUCT DATA

RATINGS AND SPECIFICATIONS

RATINGS

Linear Stage Model	ST2F-	A1A	A2A	A3A	A1D	A2D	A3D	C1A	C2A	C3A	C1D	C2D	C3D	
Mounted Linear Motor	SGLFW2-	30A070	30A120	30A230	30D070	30D120	30D230	90A200	90A380	90A560	90D200	90D380	90D560	
Power Supply	V	100V / 200V	100V / 200V	100V / 200V	400V	400V	400V	200V	200V	200V	400V	400V	400V	
Rated Speed *1	m/s	4.0	4.0	4.0	4.0	4.0	4.0	4.0	4.0	4.0	4.0	4.0	4.0	
Maximum Speed *1	m/s	5.0	5.0	5.0	5.0	5.0	5.0	4.0	4.0	4.0	4.0	4.0	4.0	
Rated Force *1,*2	N	45	90	180	170	45	90	180	560	1120	1680	560	1120	1680
Maximum Force *1	N	135	270	540	500	135	270	540	1680	3360	5040	1680	3360	5040
Force Constant	N/A _{rms}	33.3	64.5	64.5	33.3	64.5	129.0	82	82	82	154	154	154	
Motor Constant	N/V/W	11.3	17.3	24.4	11.3	17.3	24.4	58.1	82.2	101	59.2	83.7	102	
Magnetic Attraction	N	200	630	1250	200	650	1260	4240	8480	12700	4240	8480	12700	
Maximum Payload (kg)	without brake	3.3	5.8	28.7	4.7	3.3	5.8	28.7	116.5	137.2	327.0	116.5	137.2	327.0
	with brake	2.5	5.0	28.7	4.7	2.5	5.0	28.7	114.5	135.7	324.4	114.5	135.7	324.4
Moving Mass (kg)	without brake	2.3	3.6	5.3	2.3	3.6	5.3	13.5	22.8	33.0	13.5	22.8	33.0	
	with brake	3.1	4.4	5.3	3.1	4.4	5.3	15.5	24.3	35.6	15.5	24.3	35.6	
Applicable SERVOPACK	SGD7S-	1R6A, 2R1F	1R6A, 2R1F	3R8A	2R8A, 2R8F	1R9D	1R9D	1R9D	120A	200A	330A	5R4D	120D	170D
	SGD7W-	1R6A	1R6A	-	2R8A, 2R8F	2R6D	2R6D	2R6D	-	-	-	5R4D	-	-
Repeatability *3	µm	±2												

*1 These values are for operation in combination with a SERVOPACK when the temperature of the armature winding is 100°C. The values for the other items are at 20°C. These are typical values.

*2 The rated forces are the continuous allowable force values at a surrounding air temperature of 40°C with an aluminum heat sink of the following dimensions

- 150 mm x 100 mm x 10 mm: ST2F-A1A and ST2F-A1D
- 254 mm x 254 mm x 25 mm: ST2F-A2A, ST2F-A2D, ST2F-A3A, and ST2F-A3D
- 400 mm x 500 mm x 25 mm: ST2F-C1A and ST2F-C1D
- 609 mm x 762 mm x 40 mm: ST2F-C2A and ST2F-C2D
- 900 mm x 762 mm x 40 mm: ST2F-C3A and ST2F-C

*3 Units are assembled and tested fully restrained on a granite surface with a maximum surface accuracy of 15µm at 70°F. Performance of the installed unit may vary with mounting surface quality and temperature.

SPECIFICATIONS

Linear Stage Model	ST2F-	A1A	A2A	A3A	C1A	C2A	C3A	A1D	A2D	A3D	C1D	C2D	C3D
Mounted Linear Motor	SGLFW2-	30A070	30A120	30A230	90A200	90A380	90A560	30D070	30D120	30D230	90D200	90D380	90D560
Time Rating	Continuous												
Thermal Class	B												
Insulation Resistance	500 VDC, 10 MΩ min.												
Withstand Voltage	1,500 VAC for 1 minute						1,800 VAC for 1 minute						
Excitation	Permanent Magnet												
Cooling Method	Self-cooled												
Protective Structure	IPOO												
Environmental Conditions	Surrounding Air Temperature	0°C to 40°C (with no freezing)											
	Surrounding Air Humidity	20% to 80% relative humidity (with no condensation)											
	Installation Site	<ul style="list-style-type: none"> • Must be well-ventilated and free of dust and moisture • Must facilitate inspection and cleaning • Must have an altitude of 1,000 m or less • Must be free of strong magnetic fields. 											
Shock Resistance	Impact Acceleration Rate	196 m/s ²											
	Number of Impacts	2 times											
Vibration Resistance	Vibration Acceleration Rate	49 m/s ² (in three directions)											

DIMENSIONS

ST2F-A1/A2/A3 MODELS

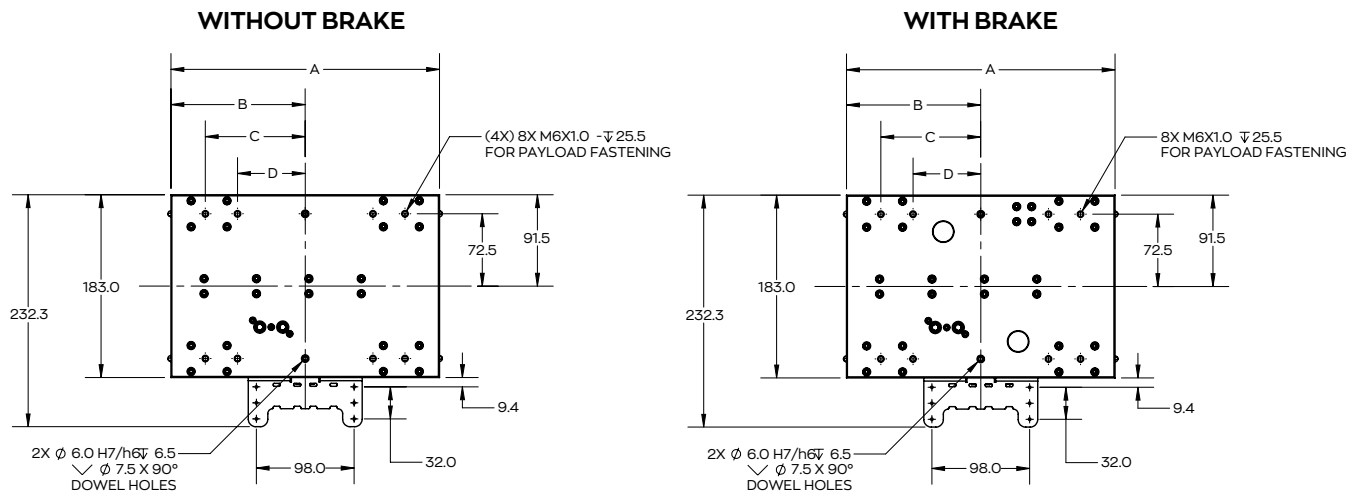
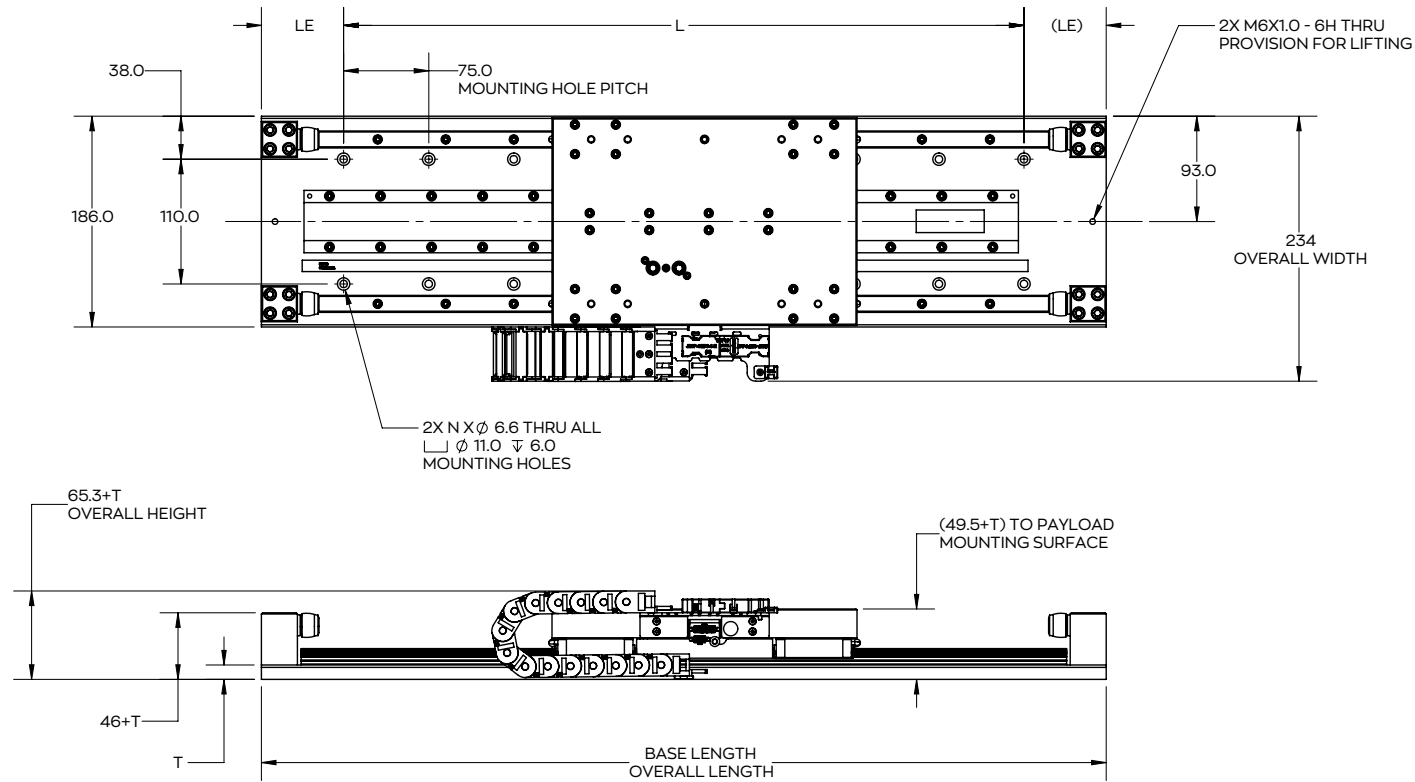

BASE DIMENSIONS

Base Length	L	LE	N	T		ST2F-A1			ST2F-A2			ST2F-A3					
				Std Base (A)	Thick Base (B)	No Option (N)	Bellows (B)	Brake (Q)	Bellows + Brake (K)	No Option (N)	Bellows (B)	Brake (Q)	Bellows + Brake (K)	No Option (N)	Bellows (B)	Brake (Q)	Bellows + Brake (K)
mm	mm	mm	holes	mm	mm	mm	mm	mm	mm	mm	mm	mm	mm	mm	mm	mm	mm
390	300	45	5	12.7	38.1	170	150	120	100	110	105	-	-	-	-	-	-
565	450	57.5	7	12.7	38.1	345	295	295	255	285	240	235	200	190	170	190	170
655	525	65	8	12.7	38.1	435	370	385	330	375	320	325	270	280	245	280	245
745	600	72.5	9	12.7	38.1	525	445	475	405	465	390	415	350	370	315	370	320
835	750	82.5	11	12.7	38.1	615	520	565	480	555	470	505	420	460	390	460	395
925	825	90	12	12.7	38.1	705	595	655	555	645	540	595	500	550	465	550	465
1015	900	97.5	13	12.7	38.1	795	670	745	630	735	615	685	570	640	540	640	540
1105	975	105	14	12.7	38.1	885	740	835	690	825	690	775	645	730	615	730	615
1195	1050	112.5	15	12.7	38.1	975	815	925	775	915	760	865	715	820	690	820	690
1285	1200	120	17	12.7	38.1	1065	890	1015	850	1005	835	955	790	910	760	910	765
1375	1275	127.5	18	12.7	38.1	1155	960	1105	920	1095	910	1045	865	1000	835	1000	840
1465	1350	135	19	12.7	38.1	1245	1040	1195	1000	1185	985	1135	940	1090	905	1090	905
1555	1425	142.5	20	12.7	38.1	1335	1110	1285	1070	1275	1060	1225	1015	1180	985	1180	985

CARRIAGE DIMENSIONS AND MOVING MASS

Without Brake

Linear Stage Model	A	B	C	D	Moving Mass
	mm	mm	mm	mm	
ST2F-A1	114.0	57.0	42.00	-	2.3
ST2F-A2	176.0	88.0	67.85	-	3.6
ST2F-A3	269.0	134.5	100.00	67.85	5.3

With Brake

Linear Stage Model	A	B	C	D	Moving Mass
	mm	mm	mm	mm	
ST2F-A1	164.0	82.0	59.70	42.00	3.1
ST2F-A2	226.0	113.0	92.80	67.85	4.4
ST2F-A3	269.0	134.5	100.00	67.85	5.3

Notes

Brake is only for holding the Sigma Trac II in static load. Not designed for stopping.

Brake air supply should be clean and dry (no oil in the lines). Required pressure is 5.5 bar (79 psi) to 6.5 bar (94 psi). Ø4 mm O.D. air hose supplied without connector.

The center pair of mounting holes on the base are inaccessible on the following models. Removal of the carriage to gain access to these holes may cause serious injury and damage to the unit.

- ST2F-A2-O390- _____
- ST2F-A3-O565- _____

DIMENSIONS

ST2F-C1/C2/C3 MODELS

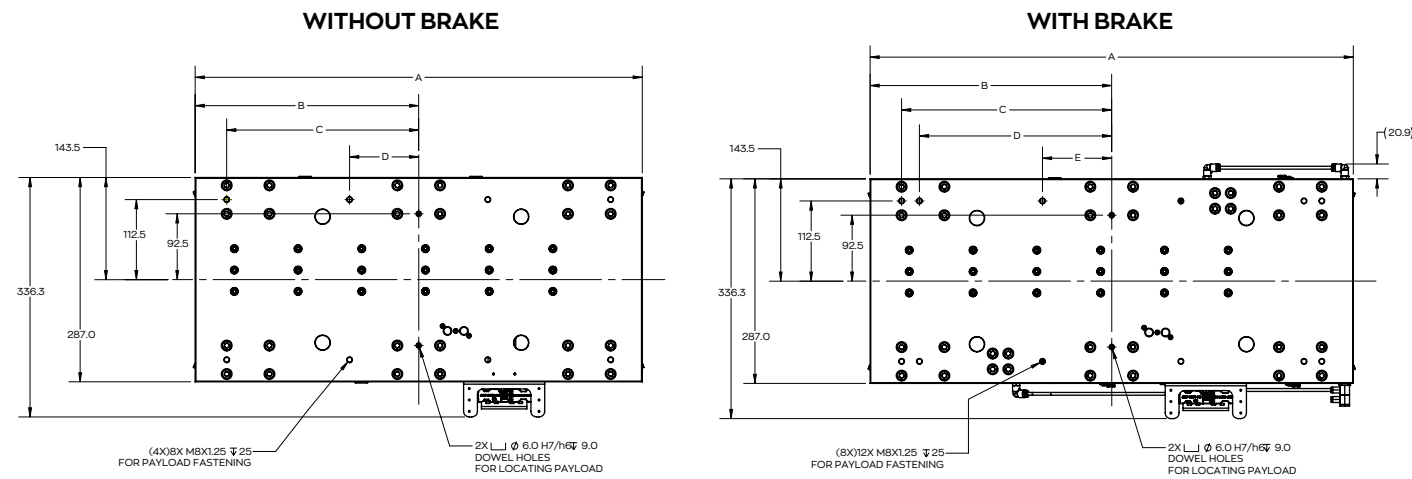
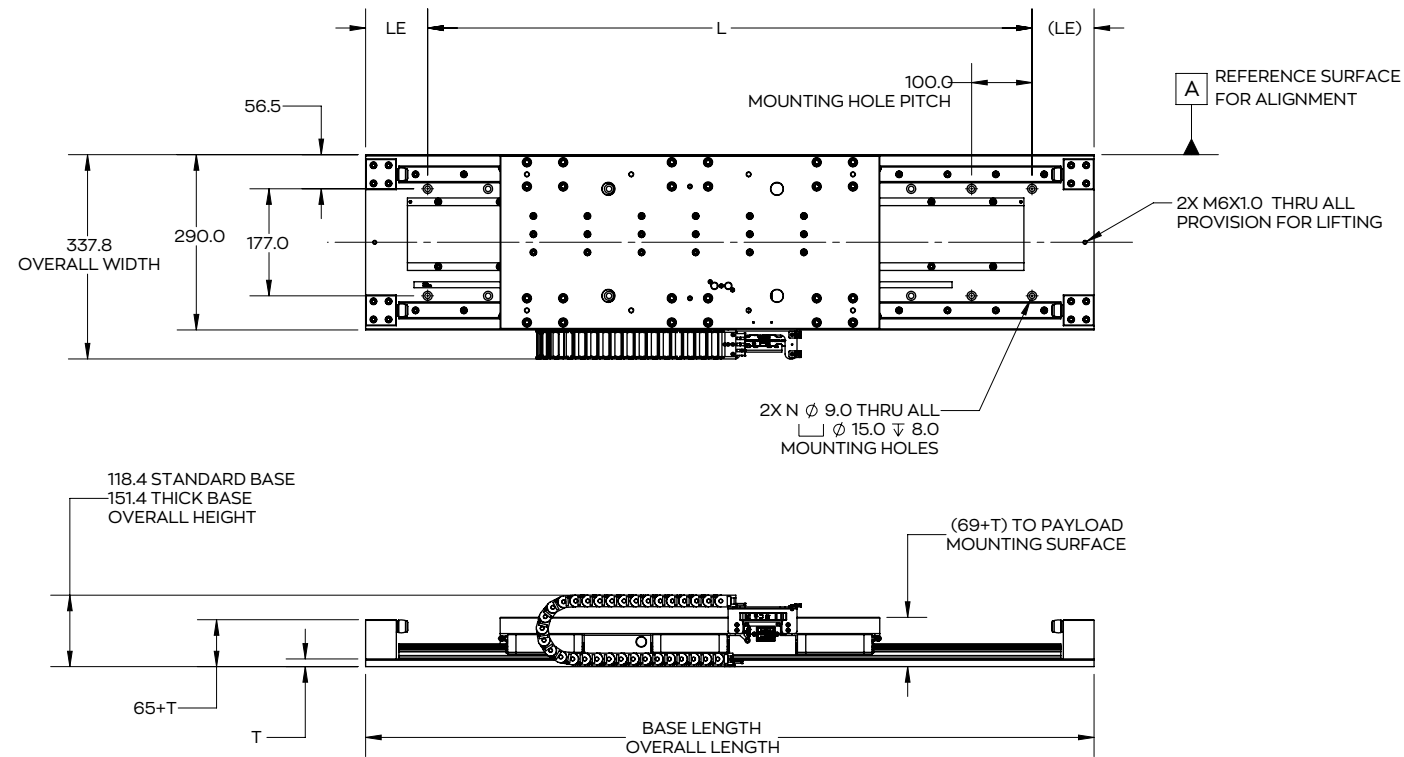

BASE DIMENSIONS

Base Length	L	LE	N	T		ST2F-C1			ST2F-C2			ST2F-C3					
				Std Base (A)	Thick Base (B)	No Option (N)	Bellows (B)	Brake (Q)	Bellows + Brake (K)	No Option (N)	Bellows (B)	Brake (Q)	Bellows + Brake (K)	No Option (N)	Bellows (B)	Brake (Q)	Bellows + Brake (K)
mm	mm	mm	holes	mm	mm	mm	mm	mm	mm	mm	mm	mm	mm	mm	mm	mm	mm
800	600	100	7	12.7	38.1	385	335	330	290	210	185	210	185	-	-	-	-
900	700	100	8	12.7	38.1	485	415	430	370	310	265	310	265	-	-	-	-
1000	800	100	9	12.7	38.1	585	505	530	455	410	350	410	350	230	200	-	-
1105	900	102.5	10	12.7	38.1	690	590	635	540	515	435	515	435	335	290	285	245
1205	1000	102.5	11	12.7	38.1	790	675	735	630	615	520	615	520	435	370	385	335
1310	1100	105	12	12.7	38.1	895	760	840	715	720	610	720	610	540	460	490	420
1410	1200	105	13	12.7	38.1	995	850	940	800	820	695	820	695	640	540	590	505
1510	1300	105	14	12.7	38.1	1095	930	1040	880	920	780	920	780	740	630	690	585
1615	1400	107.5	15	12.7	38.1	1200	1020	1145	970	1025	865	1025	865	845	715	795	675
1715	1500	107.5	16	12.7	38.1	1300	1100	1245	1050	1125	950	1125	950	945	800	895	750
1815	1600	107.5	17	12.7	38.1	1400	1185	1345	1140	1225	1035	1225	1035	1045	880	995	845
1920	1700	110	18	12.7	38.1	1505	1270	1450	1215	1330	1120	1330	1120	1150	975	1100	930

CARRIAGE DIMENSIONS AND MOVING MASS

Without Brake

Linear Stage Model	A	B	C	D	Moving Mass
	mm	mm	mm	mm	kg
ST2F-C1	270.0	135.0	97.10	-	13.5
ST2F-C2	449.0	224.5	180.00	97.10	22.8
ST2F-C3	628.0	314.0	269.75	97.10	33.0

With Brake

Linear Stage Model	A	B	C	D	E	Moving Mass
	mm	mm	mm	mm	mm	kg
ST2F-C1	325.0	162.5	124.60	97.10	-	15.5
ST2F-C2	449.0	224.5	180.00	97.10	-	24.3
ST2F-C3	678.0	339.0	294.75	269.75	97.10	35.6

Notes

Brake is only for holding the Sigma Trac II in static load. Not designed for stopping.

Brake air supply should be clean and dry (no oil in the lines). Required pressure is 5.5 bar (79 psi) to 6.5 bar (94 psi). ϕ 4 mm O.D. air hose supplied without connector.



ST2F-A1/A2/A3 MODELS

Standard Base Models

Base Length	ST2F-A1				ST2F-A2				ST2F-A3			
	No Option (N)	Bellows (B)	Brake (Q)	Bellows + Brake (K)	No Option (N)	Bellows (B)	Brake (Q)	Bellows + Brake (K)	No Option (N)	Bellows (B)	Brake (Q)	Bellows + Brake (K)
mm	kg	kg	kg	kg	kg	kg	kg	kg	kg	kg	kg	kg
390	7.6	8.0	8.4	8.7	8.9	9.2	-	-	-	-	-	-
565	9.9	10.3	10.7	11.1	11.2	11.6	12.0	12.4	12.9	13.3	13.0	13.3
655	11.1	11.5	11.8	12.2	12.4	12.8	13.1	13.5	14.1	14.5	14.1	14.5
745	12.3	12.8	13.1	13.5	13.6	14.1	14.4	14.8	15.3	15.8	15.3	15.8
835	13.5	14.0	14.2	14.7	14.8	15.3	15.5	16.0	16.5	17.0	16.5	17.0
925	14.7	15.2	15.4	15.9	16.0	16.5	16.7	17.2	17.7	18.2	17.7	18.2
1015	15.8	16.4	16.6	17.1	17.1	17.7	17.9	18.4	18.8	19.4	18.8	19.4
1105	17.0	17.6	17.7	18.4	18.3	18.9	19.0	19.6	20.0	20.6	20.0	20.6
1195	18.1	18.8	18.9	19.5	19.4	20.1	20.2	20.8	21.2	21.8	21.2	21.8
1285	19.3	20.0	20.0	20.7	20.6	21.3	21.3	22.0	22.3	22.9	22.3	22.9
1375	20.4	21.2	21.2	21.9	21.7	22.5	22.5	23.2	23.4	24.1	23.5	24.1
1465	21.7	22.5	22.4	23.2	23.0	23.8	23.8	24.6	24.7	25.4	24.7	25.4
1555	22.9	23.7	23.6	24.4	24.2	25.0	24.9	25.7	25.9	26.7	25.9	26.7

Thick Base Models

Base Length	ST2F-A1				ST2F-A2				ST2F-A3			
	No Option (N)	Bellows (B)	Brake (Q)	Bellows + Brake (K)	No Option (N)	Bellows (B)	Brake (Q)	Bellows + Brake (K)	No Option (N)	Bellows (B)	Brake (Q)	Bellows + Brake (K)
mm	kg	kg	kg	kg	kg	kg	kg	kg	kg	kg	kg	kg
390	12.6	13.0	13.4	13.7	13.9	14.2	-	-	-	-	-	-
565	17.1	17.5	17.9	18.3	18.4	18.8	19.2	19.6	20.2	20.5	20.1	20.5
655	19.3	19.8	20.0	20.5	20.6	21.0	21.4	21.8	22.3	22.7	22.3	22.7
745	21.9	22.3	22.6	23.1	23.2	23.6	23.9	24.4	24.9	25.3	24.9	25.3
835	24.2	24.7	24.9	25.4	25.5	26.0	26.2	26.7	27.2	27.6	27.2	27.6
925	26.5	27.1	27.2	27.8	27.8	28.3	28.5	29.1	29.5	30.0	29.5	30.0
1015	28.8	29.4	29.5	30.1	30.1	30.7	30.8	31.4	31.8	32.3	31.8	32.3
1105	31.1	31.7	31.8	32.5	32.4	33.0	33.1	33.7	34.1	34.7	34.1	34.7
1195	33.3	34.0	34.1	34.7	34.6	35.3	35.4	36.0	36.4	37.0	36.3	37.0
1285	35.5	36.3	36.3	37.0	36.9	37.6	37.6	38.3	38.6	39.2	38.5	39.2
1375	37.8	38.6	38.5	39.3	39.1	39.8	39.8	40.6	40.8	41.5	40.8	41.5
1465	40.4	41.2	41.1	41.9	41.7	42.5	42.4	43.3	43.4	44.1	43.4	44.1
1555	42.8	43.6	43.5	44.3	44.1	44.9	44.8	45.6	45.8	46.6	45.8	46.6

ST2F-C1/C2/C3 MODELS

Standard Base Models

Base Length	ST2F-C1				ST2F-C2				ST2F-C3			
	No Option (N)	Bellows (B)	Brake (Q)	Bellows + Brake (K)	No Option (N)	Bellows (B)	Brake (Q)	Bellows + Brake (K)	No Option (N)	Bellows (B)	Brake (Q)	Bellows + Brake (K)
mm	kg	kg	kg	kg	kg	kg	kg	kg	kg	kg	kg	kg
800	36.7	37.4	38.6	39.3	45.9	46.5	47.4	47.9	-	-	-	-
900	39.5	40.3	41.5	42.3	48.7	49.4	50.2	50.9	-	-	-	-
1000	42.4	43.3	44.4	45.3	51.7	52.4	53.1	53.9	62.0	62.6	-	-
1105	45.4	46.4	47.4	48.4	54.6	55.5	56.1	57.0	65.0	65.7	67.4	68.1
1205	48.3	49.4	50.2	51.3	57.5	57.8	59.0	60.0	67.9	68.7	70.3	71.0
1310	51.3	52.5	53.2	54.4	60.5	61.6	62.0	63.1	70.9	71.8	73.3	74.1
1410	54.2	55.5	56.1	57.4	63.4	64.6	64.9	66.0	73.8	74.8	76.2	77.1
1510	57.1	58.5	59.0	60.4	66.3	67.5	67.8	69.0	76.6	77.7	79.0	80.0
1615	60.0	61.5	62.0	63.5	69.3	70.6	70.8	72.1	79.6	80.8	82.0	83.1
1715	62.9	64.5	64.9	66.5	72.2	73.6	73.6	75.1	82.5	83.8	84.9	86.2
1815	65.9	67.5	67.8	69.5	75.1	76.6	76.6	78.1	85.5	86.8	87.8	89.1
1920	68.8	70.5	70.8	72.4	78.0	79.7	79.5	81.2	88.4	89.8	90.8	92.2

Thick Base Models

Base Length	ST2F-C1				ST2F-C2				ST2F-C3			
	No Option (N)	Bellows (B)	Brake (Q)	Bellows + Brake (K)	No Option (N)	Bellows (B)	Brake (Q)	Bellows + Brake (K)	No Option (N)	Bellows (B)	Brake (Q)	Bellows + Brake (K)
mm	kg	kg	kg	kg	kg	kg	kg	kg	kg	kg	kg	kg
800	52.9	53.7	54.9	55.6	62.1	62.6	63.6	64.2	-	-	-	-
900	57.6	58.4	59.6	60.4	66.7	67.4	68.3	69.0	-	-	-	-
1000	62.6	63.6	64.6	65.5	71.8	72.6	73.3	74.1	82.0	82.6	-	-
1105	67.7	68.7	69.6	70.6	76.8	77.7	78.4	79.3	87.1	87.8	89.6	90.3
1205	72.6	73.7	74.6	75.6	81.7	82.7	83.3	84.2	92.0	92.8	94.5	95.3
1310	77.7	78.9	79.7	80.8	86.8	87.9	88.4	89.5	97.1	98.0	99.7	100.5
1410	82.6	83.9	84.6	85.8	91.7	92.9	93.3	94.5	102.0	103.0	104.6	105.5
1510	87.5	88.9	89.4	90.8	96.6	97.9	98.2	99.4	106.9	108.0	109.4	110.4
1615	92.6	94.0	94.5	96.0	101.7	103.1	103.3	104.6	112.0	113.2	114.5	115.6
1715	97.5	99.0	99.4	101.0	106.6	108.1	108.2	109.6	116.9	118.1	119.4	120.7
1815	102.5	104.1	104.4	106.1	111.6	113.1	113.2	114.7	121.9	123.3	124.4	125.7
1920	107.4	109.1	109.4	111.1	116.6	118.3	118.1	119.8	126.8	128.3	129.4	130.8

CABLES AND ACCESSORIES

CABLES

Figure Number	Type	Linear Stage Model	Length	Order Number	
❶	Power Cable Extension (High Flex)	ST2F-A□A ST2F-A□D	1 m	JZSP-CL2N703-01-E	
			3 m	JZSP-CL2N703-03-E	
			5 m	JZSP-CL2N703-05-E	
			10 m	JZSP-CL2N703-10-E	
			15 m	JZSP-CL2N703-15-E	
			20 m	JZSP-CL2N703-20-E	
		ST2F-C1A ST2F-C2A ST2F-C1D ST2F-C2D	1 m	JZSP-CL2N803-01-E	
			3 m	JZSP-CL2N803-03-E	
			5 m	JZSP-CL2N803-05-E	
			10 m	JZSP-CL2N803-10-E	
			15 m	JZSP-CL2N803-15-E	
			20 m	JZSP-CL2N803-20-E	
		ST2F-C3A ST2F-C3D	1 m	JZSP-CL2N503-01-E	
			3 m	JZSP-CL2N503-03-E	
			5 m	JZSP-CL2N503-05-E	
			10 m	JZSP-CL2N503-10-E	
			15 m	JZSP-CL2N503-15-E	
			20 m	JZSP-CL2N503-20-E	
❷	Encoder Cable Extension (Standard)	ST2F-A□A ST2F-A□D ST2F-C□A ST2F-C□D	3 m	JZSP-CMP00-03-E	
			5 m	JZSP-CMP00-05-E	
			10 m	JZSP-CMP00-10-E	
			15 m	JZSP-CMP00-15-E	
			20 m	JZSP-CMP00-20-E	
			Encoder Cable Extension (High Flex)	3 m	JZSP-CMP10-03-E
	5 m	JZSP-CMP10-05-E			
	10 m	JZSP-CMP10-10-E			
	15 m	JZSP-CMP10-15-E			
	20 m	JZSP-CMP10-20-E			
	❸	Thermal Cable Extension (High Flex) *3		ST2F-C□A ST2F-C□D	3 m
			5 m		ST2TCBL1-05
10 m			ST2TCBL1-10		
15 m			ST2TCBL1-15		
20 m			ST2TCBL1-20		
❹	Internal Power Cable (High Flex, Small Radius) *1,*2	ST2F-A□A ST2F-A□D	2820 mm	ST2IPCBL1	
		ST2F-C□A ST2F-C□D	2820 mm	ST2IPCBL3	
❺	Internal Encoder Cable (High Flex, Small Radius) *1,*2	ST2F-A□A ST2F-A□D	2750 mm	ST2IECBL1	
❻	Internal Thermal Cable (High Flex, Small Radius) *1,*2	ST2F-C□A ST2F-C□D	2800 mm	ST2ITCBL1	

*1 This cable is included with the linear stage and is offered as a replacement part

*2 Cable length is measured from connector to connector. The amount of cable extending beyond the cable carrier depends on stroke length

*3 This cable has flying leads at the SERVOPACK end. Connect to SERVOPACK CN1 via terminal block or I/O cable

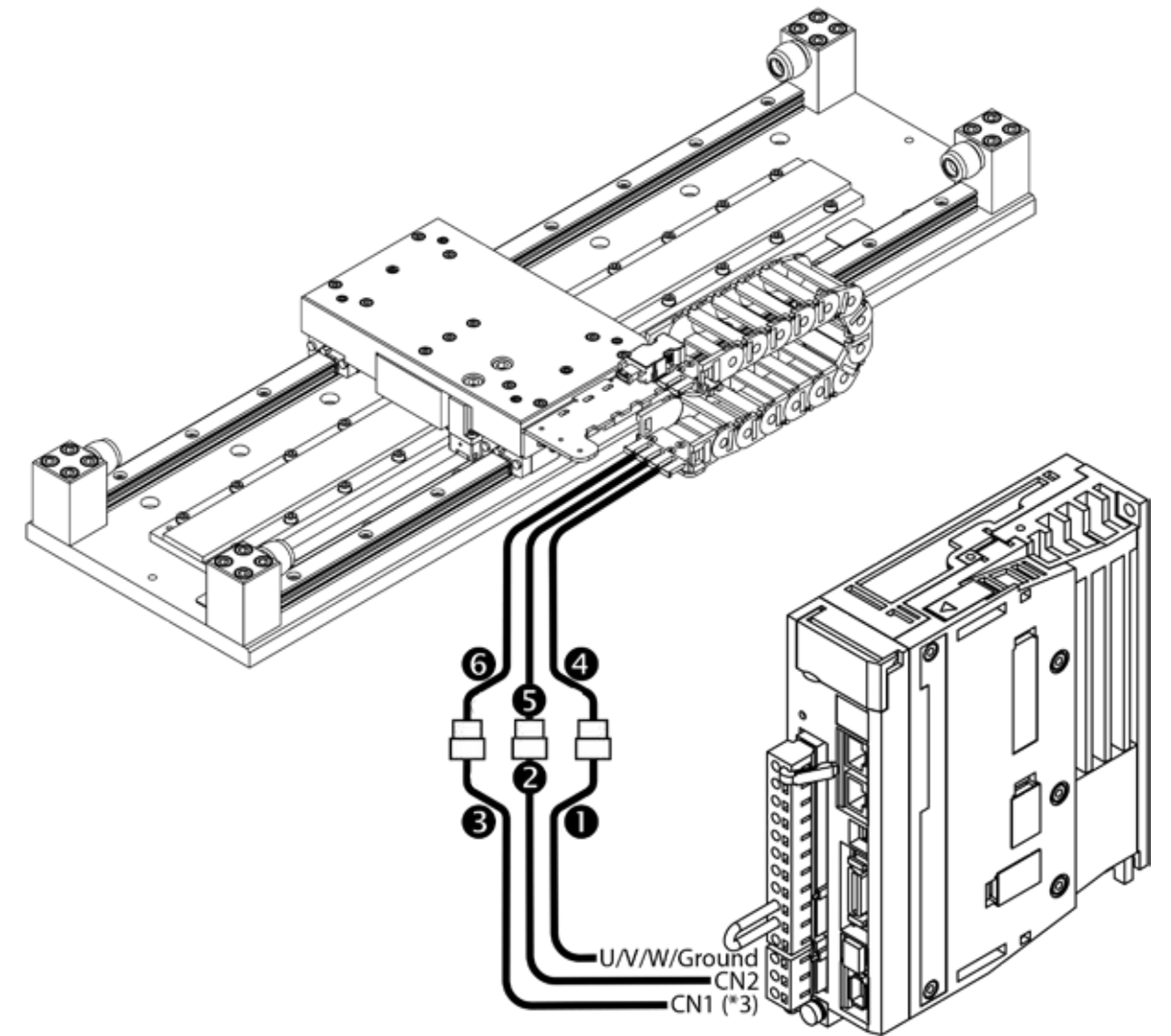

ACCESSORIES

Type	Linear Stage Models	Order Number
X-Y Adapter Kit	Base Axis: ST2F-A2, ST2F-A3 Moving Axis: ST2F-A1, ST2F-A2, ST2F-A3	ST2-XYA
	Base Axis: ST2F-C1, ST2F-C2, ST2F-C3 Moving Axis: ST2F-A1, ST2F-A2, ST2F-A3, ST2F-C1, ST2F-C2, ST2F-C3	ST2-XYC



YASKAWA.COM



Yaskawa is the leading global manufacturer of low and medium voltage variable frequency drives, servo systems, machine controllers and industrial robots. Our standard products, as well as tailor-made solutions, are well known and have a high reputation for outstanding quality and reliability.

YASKAWA

Yaskawa America, Inc. | Drives & Motion Division

1-800-YASKAWA | Email: info@yaskawa.com | yaskawa.com

Document No. BL.Sigma-7.03 | 01/25/2023 | © 2021 Yaskawa America, Inc.